



# ARIZONA DEPT OF PUBLIC SAFETY

## Trooper Report for Incident I20003903

**Nature:** OFCR INVL SHOOT

**Address:** sedona

**Location:**

**Offense Codes:** NC

**Received By:** FLORES,O

**How Received:** O

**Agency:** ADPS

**Responding Officers:** ARCHAMBEAU,D, BULGER,J, CURTIS,M, ELLIOTT,B, ELLIS JR,K, FYFE,J, GRAY,J, HANCOCK,W, HARRIS,SH, HUMPHREY,T, JAYNES,J, KADELAK,S, KARL,L, LINARES,G, MASCHUE,C, MCCABE,P, MCDONALD,J, MONACO,M, MORAN,G, OBRYANT,S, PHILPOT,J, PROCUNIER,J, RUBLE,J, SORTOR,D, VANTASSEL,M, VEGA,R, WILLIS,W, PH7893

**Responsible Officer:** REED,A

**Disposition:** PJS 06/10/20

**When Reported:** 13:54:41 01/20/20

**Occurred Between:** 13:54:34 01/20/20 and 13:54:34 01/20/20

**Assigned To:**

**Detail:**

**Date Assigned:** \*\*/\*\*/\*\*

**Status:**

**Status Date:** \*\*/\*\*/\*\*

**Due Date:** \*\*/\*\*/\*\*

### Complainant:

**Last:**

**First:**

**Mid:**

**DOB:** \*\*/\*\*/\*\*

**Dr Lic:**

**Address:**

**Race:**

**Sex:**

**Phone:**

**City:** ,

### Offense Codes

**Reported:** NC Not Classified

**Observed:**

**Additional Offense:** NC Not Classified

### Circumstances

#### Responding Officers:

#### Unit :

ARCHAMBEAU,D	D342
BULGER,J	D340
CURTIS,M	225
ELLIOTT,B	P110
ELLIS JR,K	D361
FYFE,J	D315
GRAY,J	D112
HANCOCK,W	D360
HARRIS,SH	D324
HUMPHREY,T	P111

JAYNES,J	224
KADELAK,S	D312
KARL,L	D111
LINARES,G	D314
MASCHUE,C	223
MCCABE,P	P113
MCDONALD,J	D320
MONACO,M	D310
MORAN,G	1240
OBRYANT,S	D343
PHILPOT,J	P10
PROCUNIER,J	D345
RUBLE,J	D321
SORTOR,D	D346
VANTASSEL,M	D317
VEGA,R	D300
WILLIS,W	D110
PH7893	PH7893

**Responsible Officer:** REED,A**Agency:** ADPS**Received By:** FLORES,O**Last Radio Log:** 01:38:42 01/21/20 CMPLT**How Received:** O TROOPER REPORT**Clearance:** 6 REPORT TAKEN**When Reported:** 13:54:41 01/20/20**Disposition:** PJS **Date:** 06/10/20**Judicial Status:****Occurred between:** 13:54:34 01/20/20**Misc Entry:** 31030100**and:** 13:54:34 01/20/20**Modus Operandi:****Description :****Method :****Involvements**

<b>Date</b>	<b>Type</b>	<b>Description</b>	<b>Relationship</b>
01/21/20	Name	MESSARE, JONATHAN DAVID	Suspect
01/20/20	Cad Call	13:54:41 01/20/20 OFCR INVL SHOOT	Initiating Call
05/05/20	Property	Compact Disc Pelletier's walk through 0	Evidence
05/05/20	Property	Compact Disc HUNT'S WALK THROUGH 0	Evidence
05/05/20	Property	Compact Disc HUDSPETH'S WALK THROUGH 0	Evidence
05/05/20	Property	Compact Disc DIAGRAM MEASUREMENTS 0	Evidence
05/05/20	Property	Compact Disc FROHMAN INTERVIEW 0	Evidence
05/05/20	Property	Miscellaneous USB SPD CAD RECORDS 0	Evidence
05/05/20	Property	Compact Disc HUDSPETH INTERVIEW 0	Evidence

---

05/05/20	Property	Compact Disc AUDIO OF HUNT INTERVIEW 0	Evidence
05/05/20	Property	Compact Disc PELLETIER INTERVIEW 0	Evidence
05/05/20	Property	Compact Disc AUDIO OF KOON INTERVIEW 0	Evidence
05/05/20	Property	Compact Disc MESSARE'S PHONE DOWNLOAD 0	Evidence
05/05/20	Property	Compact Disc AUTOPSY PHOTOGRAPHS 0	Evidence
02/18/20	Property	Compact Disc 0	Evidence
02/18/20	Property	Compact Disc 0	Evidence
01/28/20	Property	Disk Drive 0	Evidence
01/27/20	Property	Glove 0	Evidence
01/27/20	Property	Miscellaneous 0	Evidence
01/27/20	Property	Bag 0	Evidence
01/27/20	Property	Miscellaneous 0	Evidence
01/27/20	Property	Cash 5.08	Evidence
01/27/20	Property	Miscellaneous 0	Evidence
01/27/20	Property	Glove 0	Evidence
01/27/20	Property	Miscellaneous 0	Evidence
01/27/20	Property	Marijuana 0	Evidence
01/27/20	Property	Clothing 0	Evidence
01/27/20	Property	Clothing 0	Evidence
01/27/20	Property	Clothing 0	Evidence
01/27/20	Property	Handcuffs 0	Evidence
01/27/20	Property	Clothing 0	Evidence
01/27/20	Property	Clothing 0	Evidence
01/27/20	Property	Clothing 0	Evidence
01/27/20	Property	Clothing 0	Evidence
01/27/20	Property	Clothing 0	Evidence
01/27/20	Property	Clothing 0	Evidence
01/27/20	Property	Clothing 0	Evidence
01/27/20	Property	Clothing 0	Evidence
01/27/20	Property	Harness 0	Evidence
01/27/20	Property	Clothing 0	Evidence
01/27/20	Property	Clothing 0	Evidence
01/27/20	Property	Clothing 0	Evidence
01/27/20	Property	Bag 0	Evidence
01/27/20	Property	Clothing 0	Evidence
01/27/20	Property	Miscellaneous 0	Evidence
01/27/20	Property	Key 0	Evidence
01/27/20	Property	Case 0	Evidence
01/27/20	Property	Clothing 0	Evidence
01/27/20	Property	Bracelet 0	Evidence
01/27/20	Property	Bracelet 0	Evidence
01/27/20	Property	Miscellaneous 0	Evidence
01/27/20	Property	Key 0	Evidence
01/27/20	Property	Nail 0	Evidence
01/27/20	Property	Bullet 0	Evidence
01/27/20	Property	Fingerprint 0	Evidence

01/27/20	Property	Bullet 0	Evidence
01/27/20	Property	Blood Sample 0	Evidence
01/27/20	Property	Bullet 0	Evidence
01/27/20	Property	Bullet 0	Evidence
01/27/20	Property	Compact Disc 0	Evidence
01/21/20	Property	Glove 0	Evidence
01/21/20	Property	Casing 0	Evidence
01/21/20	Property	Casing 0	Evidence
01/21/20	Property	Casing 0	Evidence
01/21/20	Property	Casing 0	Evidence
01/21/20	Property	Casing 0	Evidence
01/21/20	Property	Glove 0	Evidence
01/21/20	Property	Package 0	Evidence
01/21/20	Property	Sunglasses 0	Evidence
01/21/20	Property	Cane 0	Evidence
01/21/20	Property	Disk Drive 0	Evidence
01/21/20	Property	Paper 0	Evidence
01/21/20	Property	Disk Drive 0	Evidence
01/21/20	Property	Drivers License 0	Evidence
01/21/20	Property	Glove 0	Evidence
01/21/20	Property	Disk Drive 0	Evidence
01/21/20	Property	Sheet 0	Evidence
01/21/20	Property	Cellular Phone 0	Evidence
01/21/20	Property	Ammunition 0	Evidence
01/21/20	Property	Ammunition 0	Evidence
01/21/20	Property	Ammunition 0	Evidence
01/21/20	Property	Ammunition 0	Evidence
01/21/20	Property	Ammunition 0	Evidence
01/21/20	Property	Ammunition 0	Evidence
01/21/20	Property	Gun 0	Evidence
01/21/20	Property	Gun 0	Evidence
01/21/20	Property	Knife 0	Evidence
01/21/20	Property	Sheet 0	Evidence
01/21/20	Property	Ax 0	Evidence
01/21/20	Property	Sword 0	Evidence
05/05/20	Evidence	PELLETIER'S WALK THROUGH	Evidence Incident
05/05/20	Evidence	HUNT'S WALK THROUGH	Evidence Incident
05/05/20	Evidence	HUDSPETH'S WALK THROUGH	Evidence Incident
05/05/20	Evidence	MEASUREMENTS AND DIAGRAM	Evidence Incident
05/05/20	Evidence	FROHMAN INTERVIEW	Evidence Incident
05/05/20	Evidence	USB SPD CAD RECORDS, 911 CALLS	Evidence Incident

---

05/05/20	Evidence	AUDIO OF HUDSPETH INTERVIEW	Evidence Incident
05/05/20	Evidence	AUDIO OF HUNT INTERVIEW	Evidence Incident
05/05/20	Evidence	AUDIO OF PELLETIER INTERVIEW	Evidence Incident
05/05/20	Evidence	AUDIO INTERVIEW WITH KOON	Evidence Incident
05/05/20	Evidence	MESSARE'S PHONE DOWNLOAD	Evidence Incident
05/05/20	Evidence	AUTOPSY PHOTOGRAPHS	Evidence Incident
02/18/20	Evidence		Evidence Incident
02/18/20	Evidence		Evidence Incident
01/28/20	Evidence		Evidence Incident
01/27/20	Evidence		Evidence Incident
01/27/20	Evidence	Black Lighter and Sharpe	Evidence Incident
01/27/20	Evidence		Evidence Incident
01/27/20	Evidence	Credigt Card,Metal Piece, Note	Evidence Incident
01/27/20	Evidence	(1) \$5, (1) nickel (3) pennies	Evidence Incident
01/27/20	Evidence	I.D. and Visa Card	Evidence Incident
01/27/20	Evidence		Evidence Incident
01/27/20	Evidence	harmonica and pipe	Evidence Incident
01/27/20	Evidence	green plant material and pipe	Evidence Incident
01/27/20	Evidence	shoe and sock	Evidence Incident
01/27/20	Evidence	shoe and sock	Evidence Incident
01/27/20	Evidence	pants and belt	Evidence Incident
01/27/20	Evidence		Evidence Incident
01/27/20	Evidence	vest	Evidence Incident
01/27/20	Evidence	vest	Evidence Incident
01/27/20	Evidence		Evidence Incident
01/27/20	Evidence	Black Scarf	Evidence Incident
01/27/20	Evidence	Brown Hat	Evidence Incident
01/27/20	Evidence		Evidence Incident
01/27/20	Evidence	gloves and mask	Evidence Incident
01/27/20	Evidence	rope, clips, pouch	Evidence Incident
01/27/20	Evidence	Handcuff Key	Evidence Incident
01/27/20	Evidence	Sheath	Evidence Incident
01/27/20	Evidence	Belt straps	Evidence Incident
01/27/20	Evidence		Evidence Incident
01/27/20	Evidence		Evidence Incident
01/27/20	Evidence	pipe and lighter	Evidence Incident
01/27/20	Evidence		Evidence Incident
01/27/20	Evidence		Evidence Incident
01/27/20	Evidence		Evidence Incident
01/27/20	Evidence		Evidence Incident
01/27/20	Evidence		Evidence Incident
01/27/20	Evidence		Evidence Incident
01/27/20	Evidence		Evidence Incident
01/27/20	Evidence		Evidence Incident

---

01/27/20	Evidence	Evidence Incident
01/27/20	Evidence	Evidence Incident
01/27/20	Evidence	Evidence Incident
01/21/20	Evidence	Evidence Incident
01/21/20	Evidence	Evidence Incident
01/21/20	Evidence	Evidence Incident
01/21/20	Evidence	Evidence Incident
01/21/20	Evidence	Evidence Incident
01/21/20	Evidence	Evidence Incident
01/21/20	Evidence	Evidence Incident
01/21/20	Evidence	Evidence Incident
01/21/20	Evidence	Evidence Incident
01/21/20	Evidence	Evidence Incident
01/21/20	Evidence	Evidence Incident
01/21/20	Evidence	Evidence Incident
01/21/20	Evidence	Evidence Incident
01/21/20	Evidence	Evidence Incident
01/21/20	Evidence	Evidence Incident
01/21/20	Evidence	Evidence Incident
01/21/20	Evidence	Evidence Incident
01/21/20	Evidence	Evidence Incident
01/21/20	Evidence	Evidence Incident
01/21/20	Evidence	Evidence Incident
01/21/20	Evidence	Evidence Incident
01/21/20	Evidence	Evidence Incident
01/21/20	Evidence	Evidence Incident
01/21/20	Evidence	Evidence Incident
01/21/20	Evidence	Evidence Incident
01/21/20	Evidence	Evidence Incident
01/21/20	Evidence	Evidence Incident
01/21/20	Evidence	Evidence Incident
01/21/20	Evidence	Evidence Incident
01/21/20	Evidence	Evidence Incident

**Narrative**

**Property****Property Number:** 21620**Item:** Compact Disc**Owner Applied Nmbr:****Brand:** Pelletier's**Model:** walk through**Year:** 0**Quantity:** 1**Meas:****Serial Nmbr:****Total Value:** \$0.00**Color:****Owner:****Agency:** ADPS ARIZONA DEPT OF PUBLIC SAFETY**Tag Number:** AR9**Accum Amt Recov:** \$0.00**Officer:** REED,A**UCR:** EVI EVIDENCE**UCR Status:****Local Status:** EVD**Storage Location:** ENVELOPE**Crime Lab Number:****Status Date:** 05/05/20**Date Released:** \*\*/\*\*/\*\***Date Recov/Rcvd:** \*\*/\*\*/\*\***Released By:****Amt Recovered:** \$0.00**Released To:****Custody:** \*\*:\*.:\*\* \*\*/\*\*/\*\***Reason:****Comments:** AUDIO OF SERGEANT PELLETIER'S WALK THROUGH**Property Number:** 21622**Item:** Compact Disc**Owner Applied Nmbr:****Brand:** HUNT'S**Model:** WALK THROUGH**Year:** 0**Quantity:** 1**Meas:****Serial Nmbr:****Total Value:** \$0.00**Color:****Owner:****Agency:** ADPS ARIZONA DEPT OF PUBLIC SAFETY**Tag Number:** AR10**Accum Amt Recov:** \$0.00**Officer:** REED,A**UCR:** EVI EVIDENCE**UCR Status:****Local Status:** EVD**Storage Location:** ENVELOPE**Crime Lab Number:****Status Date:** 05/05/20**Date Released:** \*\*/\*\*/\*\***Date Recov/Rcvd:** \*\*/\*\*/\*\***Released By:****Amt Recovered:** \$0.00**Released To:****Custody:** \*\*:\*.:\*\* \*\*/\*\*/\*\***Reason:****Comments:** AUDIO OF OFFICER HUNT'S WALK THROUGH**Property Number:** 21623



**Item:** Compact Disc **Owner Applied Nmbr:**  
**Brand:** HUDSPETH'S **Model:** WALK THROUGH  
**Year:** 0 **Quantity:** 1  
**Meas:** **Serial Nmbr:**  
**Total Value:** \$0.00 **Color:**  
**Owner:**  
**Agency:** ADPS ARIZONA DEPT OF PUBLIC SAFETY **Tag Number:** AR11  
**Accum Amt Recov:** \$0.00 **Officer:** REED,A  
**UCR:** EVI EVIDENCE **UCR Status:**  
**Local Status:** EVD **Storage Location:** ENVELOPE  
**Crime Lab Number:** **Status Date:** 05/05/20  
**Date Released:** \*\*/\*\*/\*\* **Date Recov/Rcvd:** \*\*/\*\*/\*\*  
**Released By:** **Amt Recovered:** \$0.00  
**Released To:** **Custody:** \*\*:\*\*:\*\* \*\*/\*\*/\*\*  
**Reason:**  
**Comments:** AUDIO OF OFFICER HUDSPETH'S WALK THROUGH  
**Property Number:** 21625

**Item:** Compact Disc **Owner Applied Nmbr:**  
**Brand:** DIAGRAM **Model:** MEASUREMENTS  
**Year:** 0 **Quantity:** 1  
**Meas:** **Serial Nmbr:**  
**Total Value:** \$0.00 **Color:**  
**Owner:**  
**Agency:** ADPS ARIZONA DEPT OF PUBLIC SAFETY **Tag Number:** AR12  
**Accum Amt Recov:** \$0.00 **Officer:** REED,A  
**UCR:** EVI EVIDENCE **UCR Status:**  
**Local Status:** EVD **Storage Location:** ENVELOPE  
**Crime Lab Number:** **Status Date:** 05/05/20  
**Date Released:** \*\*/\*\*/\*\* **Date Recov/Rcvd:** \*\*/\*\*/\*\*  
**Released By:** **Amt Recovered:** \$0.00  
**Released To:** **Custody:** \*\*:\*\*:\*\* \*\*/\*\*/\*\*  
**Reason:**  
**Comments:** MEASUREMENT AND DIAGRAM DATA  
**Property Number:** 21626

**Item:** Compact Disc **Owner Applied Nmbr:**  
**Brand:** FROHMAN **Model:** INTERVIEW  
**Year:** 0 **Quantity:** 1

<b>Meas:</b>	<b>Serial Nbr:</b>
<b>Total Value:</b> \$0.00	<b>Color:</b>
<b>Owner:</b>	
<b>Agency:</b> ADPS ARIZONA DEPT OF PUBLIC SAFETY	<b>Tag Number:</b> AR13
<b>Accum Amt Recov:</b> \$0.00	<b>Officer:</b> REED,A
<b>UCR:</b> EVI EVIDENCE	<b>UCR Status:</b>
<b>Local Status:</b> EVD	<b>Storage Location:</b> ENVELOPE
<b>Crime Lab Number:</b>	<b>Status Date:</b> 05/05/20
<b>Date Released:</b> **/**/**	<b>Date Recov/Rcvd:</b> **/**/**
<b>Released By:</b>	<b>Amt Recovered:</b> \$0.00
<b>Released To:</b>	<b>Custody:</b> **:*.**. **/**/**
<b>Reason:</b>	
<b>Comments:</b> AUDIO RECORDED INTERVIEW WITH SUSAN FROHMAN	
<b>Property Number:</b> 21627	
<b>Item:</b> Miscellaneous	<b>Owner Applied Nbr:</b>
<b>Brand:</b> USB SPD CAD	<b>Model:</b> RECORDS
<b>Year:</b> 0	<b>Quantity:</b> 1
<b>Meas:</b>	<b>Serial Nbr:</b>
<b>Total Value:</b> \$0.00	<b>Color:</b>
<b>Owner:</b>	
<b>Agency:</b> ADPS ARIZONA DEPT OF PUBLIC SAFETY	<b>Tag Number:</b> AR14
<b>Accum Amt Recov:</b> \$0.00	<b>Officer:</b> REED,A
<b>UCR:</b> EVI EVIDENCE	<b>UCR Status:</b>
<b>Local Status:</b> EVD	<b>Storage Location:</b> ENVELOPE
<b>Crime Lab Number:</b>	<b>Status Date:</b> 05/05/20
<b>Date Released:</b> **/**/**	<b>Date Recov/Rcvd:</b> **/**/**
<b>Released By:</b>	<b>Amt Recovered:</b> \$0.00
<b>Released To:</b>	<b>Custody:</b> **:*.**. **/**/**
<b>Reason:</b>	
<b>Comments:</b> USB THUMB DRIVE CONTAINING SPD CAD RECORDS, 911 CALLS, AND SFD RUN RECORDS	
<b>Property Number:</b> 21628	
<b>Item:</b> Compact Disc	<b>Owner Applied Nbr:</b>
<b>Brand:</b> HUDSPETH	<b>Model:</b> INTERVIEW
<b>Year:</b> 0	<b>Quantity:</b> 1
<b>Meas:</b>	<b>Serial Nbr:</b>
<b>Total Value:</b> \$0.00	<b>Color:</b>
<b>Owner:</b>	

**Agency:** ADPS ARIZONA DEPT OF PUBLIC SAFETY  
**Tag Number:** AR45  
**Accum Amt Recov:** \$0.00  
**Officer:** REED,A  
**UCR:** EVI EVIDENCE  
**UCR Status:**  
**Local Status:** EVD  
**Storage Location:** ENVELOPE  
**Crime Lab Number:**  
**Status Date:** 05/05/20  
**Date Released:** \*\*/\*\*/\*\*  
**Date Recov/Rcvd:** \*\*/\*\*/\*\*  
**Released By:**  
**Amt Recovered:** \$0.00  
**Released To:**  
**Custody:** \*\*:\*.\*\*:\*\* \*\*/\*\*/\*\*  
**Reason:**  
**Comments:** AUDIO RECORDED INTERVIEW WITH HUDSPETH

**Property Number:** 21630  
**Item:** Compact Disc  
**Owner Applied Nmbr:**

**Brand:** AUDIO OF HUNT  
**Model:** INTERVIEW  
**Year:** 0  
**Quantity:** 1  
**Meas:**  
**Serial Nmbr:**  
**Total Value:** \$0.00  
**Color:**

**Owner:**  
**Agency:** ADPS ARIZONA DEPT OF PUBLIC SAFETY  
**Tag Number:** AR46  
**Accum Amt Recov:** \$0.00  
**Officer:** REED,A  
**UCR:** EVI EVIDENCE  
**UCR Status:**  
**Local Status:** EVD  
**Storage Location:** ENVELOPE  
**Crime Lab Number:**  
**Status Date:** 05/05/20  
**Date Released:** \*\*/\*\*/\*\*  
**Date Recov/Rcvd:** \*\*/\*\*/\*\*  
**Released By:**  
**Amt Recovered:** \$0.00  
**Released To:**  
**Custody:** \*\*:\*.\*\*:\*\* \*\*/\*\*/\*\*  
**Reason:**

**Comments:** AUDIO OF OFFICER HUNT INTERVIEW  
**Property Number:** 21631  
**Item:** Compact Disc  
**Owner Applied Nmbr:**

**Brand:** PELLETIER  
**Model:** INTERVIEW  
**Year:** 0  
**Quantity:** 1  
**Meas:**  
**Serial Nmbr:**  
**Total Value:** \$0.00  
**Color:**

**Owner:**  
**Agency:** ADPS ARIZONA DEPT OF PUBLIC SAFETY  
**Tag Number:** AR47  
**Accum Amt Recov:** \$0.00  
**Officer:** REED,A  
**UCR:** EVI EVIDENCE  
**UCR Status:**

**Local Status:** EVD  
**Crime Lab Number:**  
**Date Released:** \*\*/\*\*/\*\*  
**Released By:**  
**Released To:**  
**Reason:**  
**Comments:** AUDIO OF PELLETIER INTERVIEW  
**Property Number:** 21633  
**Item:** Compact Disc  
**Storage Location:** ENVELOPE  
**Status Date:** 05/05/20  
**Date Recov/Rcvd:** \*\*/\*\*/\*\*  
**Amt Recovered:** \$0.00  
**Custody:** \*\*.\*.\* \*\*/\*\*/\*\*  
**Owner Applied Nmbr:**

**Brand:** AUDIO OF KOON  
**Year:** 0  
**Meas:**  
**Total Value:** \$0.00  
**Owner:**  
**Agency:** ADPS ARIZONA DEPT OF PUBLIC SAFETY  
**Model:** INTERVIEW  
**Quantity:** 1  
**Serial Nmbr:**  
**Color:**  
**Tag Number:** AR48

**Accum Amt Recov:** \$0.00  
**UCR:** EVI EVIDENCE  
**Local Status:** EVD  
**Crime Lab Number:**  
**Date Released:** \*\*/\*\*/\*\*  
**Released By:**  
**Released To:**  
**Reason:**  
**Comments:** AUDIO RECORDED INTERVIEW WITH CHARLIE KOON  
**Property Number:** 21634  
**Item:** Compact Disc  
**Storage Location:** ENVELOPE  
**Status Date:** 05/05/20  
**Date Recov/Rcvd:** \*\*/\*\*/\*\*  
**Amt Recovered:** \$0.00  
**Custody:** \*\*.\*.\* \*\*/\*\*/\*\*  
**Officer:** REED,A  
**UCR Status:**

**Brand:** MESSARE'S  
**Year:** 0  
**Meas:**  
**Total Value:** \$0.00  
**Owner:**  
**Agency:** ADPS ARIZONA DEPT OF PUBLIC SAFETY  
**Model:** PHONE DOWNLOAD  
**Quantity:** 1  
**Serial Nmbr:**  
**Color:**  
**Tag Number:** AR49

**Accum Amt Recov:** \$0.00  
**UCR:** EVI EVIDENCE  
**Local Status:** EVD  
**Crime Lab Number:**  
**Date Released:** \*\*/\*\*/\*\*  
**Released By:**  
**Storage Location:** ENVELOPE  
**Status Date:** 05/05/20  
**Date Recov/Rcvd:** \*\*/\*\*/\*\*  
**Amt Recovered:** \$0.00

<b>Released To:</b>	<b>Custody:</b> **:~::~~** **/**/**
<b>Reason:</b>	
<b>Comments:</b> MESSARE'S PHONE SD DOWNLOAD	
<b>Property Number:</b> 21635	
<b>Item:</b> Compact Disc	<b>Owner Applied Nmbr:</b>
<b>Brand:</b> AUTOPSY	<b>Model:</b> PHOTOGRAPHS
<b>Year:</b> 0	<b>Quantity:</b> 1
<b>Meas:</b>	<b>Serial Nmbr:</b>
<b>Total Value:</b> \$0.00	<b>Color:</b>
<b>Owner:</b>	
<b>Agency:</b> ADPS ARIZONA DEPT OF PUBLIC SAFETY	<b>Tag Number:</b> AR50
<b>Accum Amt Recov:</b> \$0.00	<b>Officer:</b> REED,A
<b>UCR:</b> EVI EVIDENCE	<b>UCR Status:</b>
<b>Local Status:</b> EVD	<b>Storage Location:</b> ENVELOPE
<b>Crime Lab Number:</b>	<b>Status Date:</b> 05/05/20
<b>Date Released:</b> **/**/**	<b>Date Recov/Rcvd:</b> **/**/**
<b>Released By:</b>	<b>Amt Recovered:</b> \$0.00
<b>Released To:</b>	<b>Custody:</b> **:~::~~** **/**/**
<b>Reason:</b>	
<b>Comments:</b> USB THUMB DRIVE AND CD WITH AUTOPSY PHOTOGRAPHS (2ND COPY)	
<b>Property Number:</b> 12917	
<b>Item:</b> Compact Disc	<b>Owner Applied Nmbr:</b>
<b>Brand:</b>	<b>Model:</b>
<b>Year:</b> 0	<b>Quantity:</b> 1
<b>Meas:</b>	<b>Serial Nmbr:</b>
<b>Total Value:</b> \$0.00	<b>Color:</b>
<b>Owner:</b>	
<b>Agency:</b> ADPS ARIZONA DEPT OF PUBLIC SAFETY	<b>Tag Number:</b> JDR1
<b>Accum Amt Recov:</b> \$0.00	<b>Officer:</b> RUBLE,J
<b>UCR:</b>	<b>UCR Status:</b>
<b>Local Status:</b> EVD	<b>Storage Location:</b> envelope
<b>Crime Lab Number:</b>	<b>Status Date:</b> 02/18/20
<b>Date Released:</b> **/**/**	<b>Date Recov/Rcvd:</b> **/**/**
<b>Released By:</b>	<b>Amt Recovered:</b> \$0.00
<b>Released To:</b>	<b>Custody:</b> **:~::~~** **/**/**
<b>Reason:</b>	
<b>Comments:</b> One compact disc containing interview with C. Harrell	
<b>Property Number:</b> 12918	

**Item:** Compact Disc **Owner Applied Nmbr:**  
**Brand:** **Model:**  
**Year:** 0 **Quantity:** 1  
**Meas:** **Serial Nmbr:**  
**Total Value:** \$0.00 **Color:**  
**Owner:**  
**Agency:** ADPS ARIZONA DEPT OF PUBLIC SAFETY **Tag Number:** JDR2  
**Accum Amt Recov:** \$0.00 **Officer:** RUBLE,J  
**UCR:** **UCR Status:**  
**Local Status:** EVD **Storage Location:** envelope  
**Crime Lab Number:** **Status Date:** 02/18/20  
**Date Released:** \*\*/\*\*/\*\* **Date Recov/Rcvd:** \*\*/\*\*/\*\*  
**Released By:** **Amt Recovered:** \$0.00  
**Released To:** **Custody:** \*\*:\*.\*\*:\*\* \*\*/\*\*/\*\*  
**Reason:**  
**Comments:** One compact disc containing interviews with Peter and Jovan McLoughlin  
**Property Number:** 10191

**Item:** Disk Drive **Owner Applied Nmbr:**  
**Brand:** **Model:**  
**Year:** 0 **Quantity:** 1  
**Meas:** **Serial Nmbr:**  
**Total Value:** \$0.00 **Color:**  
**Owner:**  
**Agency:** ADPS ARIZONA DEPT OF PUBLIC SAFETY **Tag Number:** JF1  
**Accum Amt Recov:** \$0.00 **Officer:** REED,A  
**UCR:** EVI EVIDENCE **UCR Status:**  
**Local Status:** EVD **Storage Location:** Envelope  
**Crime Lab Number:** **Status Date:** 01/28/20  
**Date Released:** \*\*/\*\*/\*\* **Date Recov/Rcvd:** \*\*/\*\*/\*\*  
**Released By:** **Amt Recovered:** \$0.00  
**Released To:** **Custody:** \*\*:\*.\*\*:\*\* \*\*/\*\*/\*\*  
**Reason:**  
**Comments:** Dash Cam video from patrol vehicles (MVA.1, MB.1, MVC.1).  
**Property Number:** 10084

**Item:** Glove **Owner Applied Nmbr:**

**Brand:** **Model:**  
**Year:** 0 **Quantity:** 1

**Meas:**  
**Total Value:** \$0.00  
**Owner:**  
**Agency:** ADPS ARIZONA DEPT OF PUBLIC SAFETY  
**Accum Amt Recov:** \$0.00  
**UCR:**  
**Local Status:** EVD  
**Crime Lab Number:**  
**Date Released:** \*\*/\*\*/\*\*  
**Released By:**  
**Released To:**  
**Reason:**  
**Comments:** Gray Mit from left side pants pocket. Collect by M.E. during Autopsy. Autopsy evidence # 1  
**Property Number:** 10086  
**Item:** Miscellaneous  
**Serial Nmbr:**  
**Color:**  
**Tag Number:** AR15  
**Officer:** REED,A  
**UCR Status:**  
**Storage Location:** Envelope  
**Status Date:** 01/27/20  
**Date Recov/Rcvd:** \*\*/\*\*/\*\*  
**Amt Recovered:** \$0.00  
**Custody:** \*\*:\*\*.\*\*. \*\*/\*\*/\*\*

**Brand:**  
**Year:** 0  
**Meas:**  
**Total Value:** \$0.00  
**Owner:**  
**Agency:** ADPS ARIZONA DEPT OF PUBLIC SAFETY  
**Accum Amt Recov:** \$0.00  
**UCR:**  
**Local Status:** EVD  
**Crime Lab Number:**  
**Date Released:** \*\*/\*\*/\*\*  
**Released By:**  
**Released To:**  
**Reason:**  
**Comments:** Black lighter and Sharpe collected by M.E. during Autospy. M.E. Evidence item # 2  
**Property Number:** 10087  
**Item:** Bag  
**Owner Applied Nmbr:**  
**Model:**  
**Quantity:** 2  
**Serial Nmbr:**  
**Color:**  
**Tag Number:** AR16  
**Officer:** REED,A  
**UCR Status:**  
**Storage Location:** Envelope  
**Status Date:** 01/27/20  
**Date Recov/Rcvd:** \*\*/\*\*/\*\*  
**Amt Recovered:** \$0.00  
**Custody:** \*\*:\*\*.\*\*. \*\*/\*\*/\*\*

**Brand:**  
**Year:** 0  
**Meas:**  
**Total Value:** \$0.00  
**Owner:**  
**Model:**  
**Quantity:** 1  
**Serial Nmbr:**  
**Color:**

**Agency:** ADPS ARIZONA DEPT OF PUBLIC SAFETY  
**Tag Number:** AR17  
**Accum Amt Recov:** \$0.00  
**Officer:** REED,A  
**UCR:**  
**UCR Status:**  
**Local Status:** EVD  
**Storage Location:** Envelope  
**Crime Lab Number:**  
**Status Date:** 01/27/20  
**Date Released:** \*\*/\*\*/\*\*  
**Date Recov/Rcvd:** \*\*/\*\*/\*\*  
**Released By:**  
**Amt Recovered:** \$0.00  
**Released To:**  
**Custody:** \*\*:\*.\*\*:\*\* \*\*/\*\*/\*\*  
**Reason:**  
**Comments:** M.E. Evidence Bag #3  
**Property Number:** 10088  
**Item:** Miscellaneous  
**Owner Applied Nmbr:**

**Brand:**  
**Model:**  
**Year:** 0  
**Quantity:** 3  
**Meas:**  
**Serial Nmbr:**  
**Total Value:** \$0.00  
**Color:**  
**Owner:**  
**Agency:** ADPS ARIZONA DEPT OF PUBLIC SAFETY  
**Tag Number:** AR17.1  
**Accum Amt Recov:** \$0.00  
**Officer:** REED,A  
**UCR:**  
**UCR Status:**  
**Local Status:** EVD  
**Storage Location:** Envelope  
**Crime Lab Number:**  
**Status Date:** 01/27/20  
**Date Released:** \*\*/\*\*/\*\*  
**Date Recov/Rcvd:** \*\*/\*\*/\*\*  
**Released By:**  
**Amt Recovered:** \$0.00  
**Released To:**  
**Custody:** \*\*:\*.\*\*:\*\* \*\*/\*\*/\*\*  
**Reason:**  
**Comments:** Credit Card,metal piece, and Notes collected by M.E. during Autopsy. M.E. Evidence item #3  
**Property Number:** 10091  
**Item:** Cash  
**Owner Applied Nmbr:**

**Brand:**  
**Model:**  
**Year:** 0  
**Quantity:** 1  
**Meas:**  
**Serial Nmbr:**  
**Total Value:** \$5.08  
**Color:**  
**Owner:**  
**Agency:** ADPS ARIZONA DEPT OF PUBLIC SAFETY  
**Tag Number:** AR17.2  
**Accum Amt Recov:** \$0.00  
**Officer:** REED,A  
**UCR:**  
**UCR Status:**



**Local Status:** EVD  
**Crime Lab Number:**  
**Date Released:** \*\*/\*\*/\*\*  
**Released By:**  
**Released To:**  
**Reason:**

**Storage Location:** Envelope  
**Status Date:** 01/27/20  
**Date Recov/Rcvd:** \*\*/\*\*/\*\*  
**Amt Recovered:** \$0.00  
**Custody:** \*\*.\*.\* \*\*/\*\*/\*\*

**Comments:** \$5.08 collected from subject by M.E. during Autopsy. M.E. Evidence item # 3  
**Property Number:** 10093  
**Item:** Miscellaneous **Owner Applied Nmbr:**

**Brand:** **Model:**  
**Year:** 0 **Quantity:** 3  
**Meas:** **Serial Nmbr:**  
**Total Value:** \$0.00 **Color:**  
**Owner:**  
**Agency:** ADPS ARIZONA DEPT OF PUBLIC SAFETY **Tag Number:** AR17.3

**Accum Amt Recov:** \$0.00 **Officer:** REED,A  
**UCR:** **UCR Status:**

**Local Status:** EVD  
**Crime Lab Number:**  
**Date Released:** \*\*/\*\*/\*\*  
**Released By:**  
**Released To:**  
**Reason:**

**Storage Location:** Envelope  
**Status Date:** 01/27/20  
**Date Recov/Rcvd:** \*\*/\*\*/\*\*  
**Amt Recovered:** \$0.00  
**Custody:** \*\*.\*.\* \*\*/\*\*/\*\*

**Comments:** Oregon DL, Military I.D., and River Mark Visa Card from subject collected by M.E. during Autopsy. M.E. Evidence item #3

**Property Number:** 10094  
**Item:** Glove **Owner Applied Nmbr:**

**Brand:** **Model:**  
**Year:** 0 **Quantity:** 1  
**Meas:** **Serial Nmbr:**  
**Total Value:** \$0.00 **Color:**  
**Owner:**  
**Agency:** ADPS ARIZONA DEPT OF PUBLIC SAFETY **Tag Number:** AR20

**Accum Amt Recov:** \$0.00 **Officer:** REED,A  
**UCR:** **UCR Status:**

**Local Status:** EVD  
**Crime Lab Number:**  
**Date Released:** \*\*/\*\*/\*\*

**Storage Location:** Envelope  
**Status Date:** 01/27/20  
**Date Recov/Rcvd:** \*\*/\*\*/\*\*

<b>Released By:</b>	<b>Amt Recovered:</b> \$0.00
<b>Released To:</b>	<b>Custody:</b> **:~::~~** **/**/**
<b>Reason:</b>	
<b>Comments:</b> Gray Mit from subject collected right side pants pocket by M.E. during Autopsy. M.E. Evidence item #6	
<b>Property Number:</b> 10095	<b>Owner Applied Nmbr:</b>
<b>Item:</b> Miscellaneous	
<b>Brand:</b>	<b>Model:</b>
<b>Year:</b> 0	<b>Quantity:</b> 2
<b>Meas:</b>	<b>Serial Nmbr:</b>
<b>Total Value:</b> \$0.00	<b>Color:</b>
<b>Owner:</b>	
<b>Agency:</b> ADPS ARIZONA DEPT OF PUBLIC SAFETY	<b>Tag Number:</b> AR19
<b>Accum Amt Recov:</b> \$0.00	<b>Officer:</b> REED,A
<b>UCR:</b>	<b>UCR Status:</b>
<b>Local Status:</b> EVD	<b>Storage Location:</b> Envelope
<b>Crime Lab Number:</b>	<b>Status Date:</b> 01/27/20
<b>Date Released:</b> **/**/**	<b>Date Recov/Rcvd:</b> **/**/**
<b>Released By:</b>	<b>Amt Recovered:</b> \$0.00
<b>Released To:</b>	<b>Custody:</b> **:~::~~** **/**/**
<b>Reason:</b>	
<b>Comments:</b> pipe and harmonica from subjects front right pants pocket collected by M.E. during Autopsy. M.E. Evidence item #5	
<b>Property Number:</b> 10096	<b>Owner Applied Nmbr:</b>
<b>Item:</b> Marijuana	
<b>Brand:</b>	<b>Model:</b>
<b>Year:</b> 0	<b>Quantity:</b> 1
<b>Meas:</b>	<b>Serial Nmbr:</b>
<b>Total Value:</b> \$0.00	<b>Color:</b>
<b>Owner:</b>	
<b>Agency:</b> ADPS ARIZONA DEPT OF PUBLIC SAFETY	<b>Tag Number:</b> AR18
<b>Accum Amt Recov:</b> \$0.00	<b>Officer:</b> REED,A
<b>UCR:</b>	<b>UCR Status:</b>
<b>Local Status:</b> EVD	<b>Storage Location:</b> Envelope
<b>Crime Lab Number:</b>	<b>Status Date:</b> 01/27/20
<b>Date Released:</b> **/**/**	<b>Date Recov/Rcvd:</b> **/**/**
<b>Released By:</b>	<b>Amt Recovered:</b> \$0.00
<b>Released To:</b>	<b>Custody:</b> **:~::~~** **/**/**

**Reason:**

**Comments:** M.E. Evidence bag, brown leather pouch containing green plant material, and small metal pipe collected from subject by M.E. during Autopsy. M.E. Evidence item #4

**Property Number:** 10097

**Item:** Clothing

**Owner Applied Nmbr:**

**Brand:**

**Model:**

**Year:** 0

**Quantity:** 2

**Meas:**

**Serial Nmbr:**

**Total Value:** \$0.00

**Color:**

**Owner:**

**Agency:** ADPS ARIZONA DEPT OF PUBLIC SAFETY

**Tag Number:** AR21

**Accum Amt Recov:** \$0.00

**Officer:** REED,A

**UCR:**

**UCR Status:**

**Local Status:** EVD

**Storage Location:** Box

**Crime Lab Number:**

**Status Date:** 01/27/20

**Date Released:** \*\*/\*\*/\*\*

**Date Recov/Rcvd:** \*\*/\*\*/\*\*

**Released By:**

**Amt Recovered:** \$0.00

**Released To:**

**Custody:** \*\*:\*.\*\*:\*\* \*\*/\*\*/\*\*

**Reason:**

**Comments:** Left shoe and sock from subject collected by M.E. during Autopsy. M.E. Evidence item #7

**Property Number:** 10098

**Item:** Clothing

**Owner Applied Nmbr:**

**Brand:**

**Model:**

**Year:** 0

**Quantity:** 2

**Meas:**

**Serial Nmbr:**

**Total Value:** \$0.00

**Color:**

**Owner:**

**Agency:** ADPS ARIZONA DEPT OF PUBLIC SAFETY

**Tag Number:** AR22

**Accum Amt Recov:** \$0.00

**Officer:** REED,A

**UCR:**

**UCR Status:**

**Local Status:** EVD

**Storage Location:** Box

**Crime Lab Number:**

**Status Date:** 01/27/20

**Date Released:** \*\*/\*\*/\*\*

**Date Recov/Rcvd:** \*\*/\*\*/\*\*

**Released By:**

**Amt Recovered:** \$0.00

**Released To:**

**Custody:** \*\*:\*.\*\*:\*\* \*\*/\*\*/\*\*

**Reason:**

**Comments:** Right shoe and sock from subject collected by M.E. during Autopsy. M.E. Evidence item #8

**Property Number:** 10099

**Item:** Clothing **Owner Applied Nmbr:**

**Brand:** **Model:**  
**Year:** 0 **Quantity:** 2  
**Meas:** **Serial Nmbr:**  
**Total Value:** \$0.00 **Color:**  
**Owner:**  
**Agency:** ADPS ARIZONA DEPT OF PUBLIC SAFETY **Tag Number:** AR23  
**Accum Amt Recov:** \$0.00 **Officer:** REED,A  
**UCR:** **UCR Status:**  
**Local Status:** EVD **Storage Location:** Box  
**Crime Lab Number:** **Status Date:** 01/27/20  
**Date Released:** \*\*/\*\*/\*\* **Date Recov/Rcvd:** \*\*/\*\*/\*\*  
**Released By:** **Amt Recovered:** \$0.00  
**Released To:** **Custody:** \*\*:\*.\*\*:\*\* \*\*/\*\*/\*\*  
**Reason:**  
**Comments:** Green pants and brown belt from subject collected by M.E. during Autopsy. M.E. Evidence item #9  
**Property Number:** 10100

**Item:** Handcuffs **Owner Applied Nmbr:**

**Brand:** **Model:**  
**Year:** 0 **Quantity:** 1  
**Meas:** **Serial Nmbr:**  
**Total Value:** \$0.00 **Color:**  
**Owner:**  
**Agency:** ADPS ARIZONA DEPT OF PUBLIC SAFETY **Tag Number:** AR24  
**Accum Amt Recov:** \$0.00 **Officer:** REED,A  
**UCR:** **UCR Status:**  
**Local Status:** EVD **Storage Location:** Envelope  
**Crime Lab Number:** **Status Date:** 01/27/20  
**Date Released:** \*\*/\*\*/\*\* **Date Recov/Rcvd:** \*\*/\*\*/\*\*  
**Released By:** **Amt Recovered:** \$0.00  
**Released To:** **Custody:** \*\*:\*.\*\*:\*\* \*\*/\*\*/\*\*  
**Reason:**  
**Comments:** Handcuffs taken off subject collected by M.E. during Autopsy. M.E. Evidence item #10  
**Property Number:** 10101

**Item:** Clothing **Owner Applied Nmbr:**

**Brand:** **Model:**  
**Year:** 0 **Quantity:** 1

<b>Meas:</b>	<b>Serial Nmbr:</b>
<b>Total Value:</b> \$0.00	<b>Color:</b>
<b>Owner:</b>	
<b>Agency:</b> ADPS ARIZONA DEPT OF PUBLIC SAFETY	<b>Tag Number:</b> AR25
<b>Accum Amt Recov:</b> \$0.00	<b>Officer:</b> REED,A
<b>UCR:</b>	<b>UCR Status:</b>
<b>Local Status:</b> EVD	<b>Storage Location:</b> Box
<b>Crime Lab Number:</b>	<b>Status Date:</b> 01/27/20
<b>Date Released:</b> **/**/**	<b>Date Recov/Rcvd:</b> **/**/**
<b>Released By:</b>	<b>Amt Recovered:</b> \$0.00
<b>Released To:</b>	<b>Custody:</b> **:*.:** **/**/**
<b>Reason:</b>	

**Comments:** Camo Vest from subject collected by M.E. during Autopsy. M.E. Evidence item #11

**Property Number:** 10102  
**Item:** Clothing

**Owner Applied Nmbr:**

<b>Brand:</b>	<b>Model:</b>
<b>Year:</b> 0	<b>Quantity:</b> 1
<b>Meas:</b>	<b>Serial Nmbr:</b>
<b>Total Value:</b> \$0.00	<b>Color:</b>
<b>Owner:</b>	
<b>Agency:</b> ADPS ARIZONA DEPT OF PUBLIC SAFETY	<b>Tag Number:</b> AR26
<b>Accum Amt Recov:</b> \$0.00	<b>Officer:</b> REED,A
<b>UCR:</b>	<b>UCR Status:</b>
<b>Local Status:</b> EVD	<b>Storage Location:</b> Box
<b>Crime Lab Number:</b>	<b>Status Date:</b> 01/27/20
<b>Date Released:</b> **/**/**	<b>Date Recov/Rcvd:</b> **/**/**
<b>Released By:</b>	<b>Amt Recovered:</b> \$0.00
<b>Released To:</b>	<b>Custody:</b> **:*.:** **/**/**
<b>Reason:</b>	

**Comments:** Green Vest from subject collected by M.E. during Autopsy. M.E. Evidence item #12

**Property Number:** 10103  
**Item:** Harness

**Owner Applied Nmbr:**

<b>Brand:</b>	<b>Model:</b>
<b>Year:</b> 0	<b>Quantity:</b> 1
<b>Meas:</b>	<b>Serial Nmbr:</b>
<b>Total Value:</b> \$0.00	<b>Color:</b>
<b>Owner:</b>	

**Agency:** ADPS ARIZONA DEPT OF PUBLIC SAFETY  
**Tag Number:** AR27  
**Accum Amt Recov:** \$0.00  
**Officer:** REED,A  
**UCR:**  
**UCR Status:**  
**Local Status:** EVD  
**Storage Location:** Box  
**Crime Lab Number:**  
**Status Date:** 01/27/20  
**Date Released:** \*\*/\*\*/\*\*  
**Date Recov/Rcvd:** \*\*/\*\*/\*\*  
**Released By:**  
**Amt Recovered:** \$0.00  
**Released To:**  
**Custody:** \*\*:\*.\*\*:\*\* \*\*/\*\*/\*\*  
**Reason:**  
**Comments:** harness from subject collected by M.E. during Autopsy. M.E. Evidence item #13  
**Property Number:** 10104  
**Item:** Clothing  
**Owner Applied Nbr:**

**Brand:**  
**Model:**  
**Year:** 0  
**Quantity:** 1  
**Meas:**  
**Serial Nbr:**  
**Total Value:** \$0.00  
**Color:**  
**Owner:**

**Agency:** ADPS ARIZONA DEPT OF PUBLIC SAFETY  
**Tag Number:** AR28  
**Accum Amt Recov:** \$0.00  
**Officer:** REED,A  
**UCR:**  
**UCR Status:**  
**Local Status:** EVD  
**Storage Location:** Envelope  
**Crime Lab Number:**  
**Status Date:** 01/27/20  
**Date Released:** \*\*/\*\*/\*\*  
**Date Recov/Rcvd:** \*\*/\*\*/\*\*  
**Released By:**  
**Amt Recovered:** \$0.00  
**Released To:**  
**Custody:** \*\*:\*.\*\*:\*\* \*\*/\*\*/\*\*  
**Reason:**  
**Comments:** Black scarf from subject collected by M.E. during Autopsy. M.E. Evidence item #14  
**Property Number:** 10105  
**Item:** Clothing  
**Owner Applied Nbr:**

**Brand:**  
**Model:**  
**Year:** 0  
**Quantity:** 1  
**Meas:**  
**Serial Nbr:**  
**Total Value:** \$0.00  
**Color:**  
**Owner:**

**Agency:** ADPS ARIZONA DEPT OF PUBLIC SAFETY  
**Tag Number:** AR29  
**Accum Amt Recov:** \$0.00  
**Officer:** REED,A  
**UCR:**  
**UCR Status:**

<b>Local Status:</b> EVD	<b>Storage Location:</b> Envelope
<b>Crime Lab Number:</b>	<b>Status Date:</b> 01/27/20
<b>Date Released:</b> **/**/**	<b>Date Recov/Rcvd:</b> **/**/**
<b>Released By:</b>	<b>Amt Recovered:</b> \$0.00
<b>Released To:</b>	<b>Custody:</b> **.*.* **/**/**
<b>Reason:</b>	
<b>Comments:</b> Brown hat from subject collected by M.E. during Autopsy. M.E. Evidence item #15	
<b>Property Number:</b> 10106	
<b>Item:</b> Bag	<b>Owner Applied Nmbr:</b>
<b>Brand:</b>	<b>Model:</b>
<b>Year:</b> 0	<b>Quantity:</b> 1
<b>Meas:</b>	<b>Serial Nmbr:</b>
<b>Total Value:</b> \$0.00	<b>Color:</b>
<b>Owner:</b>	
<b>Agency:</b> ADPS ARIZONA DEPT OF PUBLIC SAFETY	<b>Tag Number:</b> AR30
<b>Accum Amt Recov:</b> \$0.00	<b>Officer:</b> REED,A
<b>UCR:</b>	<b>UCR Status:</b>
<b>Local Status:</b> EVD	<b>Storage Location:</b> Envelope
<b>Crime Lab Number:</b>	<b>Status Date:</b> 01/27/20
<b>Date Released:</b> **/**/**	<b>Date Recov/Rcvd:</b> **/**/**
<b>Released By:</b>	<b>Amt Recovered:</b> \$0.00
<b>Released To:</b>	<b>Custody:</b> **.*.* **/**/**
<b>Reason:</b>	
<b>Comments:</b> M.E. Evidence bag #16	
<b>Property Number:</b> 10107	
<b>Item:</b> Clothing	<b>Owner Applied Nmbr:</b>
<b>Brand:</b>	<b>Model:</b>
<b>Year:</b> 0	<b>Quantity:</b> 3
<b>Meas:</b>	<b>Serial Nmbr:</b>
<b>Total Value:</b> \$0.00	<b>Color:</b>
<b>Owner:</b>	
<b>Agency:</b> ADPS ARIZONA DEPT OF PUBLIC SAFETY	<b>Tag Number:</b> AR30.1
<b>Accum Amt Recov:</b> \$0.00	<b>Officer:</b> REED,A
<b>UCR:</b>	<b>UCR Status:</b>
<b>Local Status:</b> EVD	<b>Storage Location:</b> Envelope
<b>Crime Lab Number:</b>	<b>Status Date:</b> 01/27/20
<b>Date Released:</b> **/**/**	<b>Date Recov/Rcvd:</b> **/**/**
<b>Released By:</b>	<b>Amt Recovered:</b> \$0.00

**Released To:** **Custody:** \*\*:~::~~\*\* \*\*/\*\*/\*\*  
**Reason:**  
**Comments:** 1 pair of camo gloves, and mask from subject collected by M.E. during Autopsy. M.E. Evidence item #16  
**Property Number:** 10109  
**Item:** Miscellaneous **Owner Applied Nmbr:**  
**Brand:** **Model:**  
**Year:** 0 **Quantity:** 3  
**Meas:** **Serial Nmbr:**  
**Total Value:** \$0.00 **Color:**  
**Owner:**  
**Agency:** ADPS ARIZONA DEPT OF PUBLIC SAFETY **Tag Number:** AR30.2  
**Accum Amt Recov:** \$0.00 **Officer:** REED,A  
**UCR:** **UCR Status:**  
**Local Status:** EVD **Storage Location:** Envelope  
**Crime Lab Number:** **Status Date:** 01/27/20  
**Date Released:** \*\*/\*\*/\*\* **Date Recov/Rcvd:** \*\*/\*\*/\*\*  
**Released By:** **Amt Recovered:** \$0.00  
**Released To:** **Custody:** \*\*:~::~~\*\* \*\*/\*\*/\*\*  
**Reason:**  
**Comments:** rope, clips, and pouch from subject collected by M.E. during autopsy, evidence bag #16  
**Property Number:** 10110  
**Item:** Key **Owner Applied Nmbr:**  
**Brand:** **Model:**  
**Year:** 0 **Quantity:** 1  
**Meas:** **Serial Nmbr:**  
**Total Value:** \$0.00 **Color:**  
**Owner:**  
**Agency:** ADPS ARIZONA DEPT OF PUBLIC SAFETY **Tag Number:** AR30.3  
**Accum Amt Recov:** \$0.00 **Officer:** REED,A  
**UCR:** **UCR Status:**  
**Local Status:** EVD **Storage Location:** Envelope  
**Crime Lab Number:** **Status Date:** 01/27/20  
**Date Released:** \*\*/\*\*/\*\* **Date Recov/Rcvd:** \*\*/\*\*/\*\*  
**Released By:** **Amt Recovered:** \$0.00  
**Released To:** **Custody:** \*\*:~::~~\*\* \*\*/\*\*/\*\*  
**Reason:**  
**Comments:** collected from subject collected by M.E. during autopsy, evidence bag #16



**Property Number:** 10111

**Item:** Case

**Owner Applied Nmbr:**

**Brand:**

**Model:**

**Year:** 0

**Quantity:** 1

**Meas:**

**Serial Nmbr:**

**Total Value:** \$0.00

**Color:**

**Owner:**

**Agency:** ADPS ARIZONA DEPT OF PUBLIC SAFETY

**Tag Number:** AR31

**Accum Amt Recov:** \$0.00

**Officer:** REED,A

**UCR:**

**UCR Status:**

**Local Status:** EVD

**Storage Location:** Envelope

**Crime Lab Number:**

**Status Date:** 01/27/20

**Date Released:** \*\*/\*\*/\*\*

**Date Recov/Rcvd:** \*\*/\*\*/\*\*

**Released By:**

**Amt Recovered:** \$0.00

**Released To:**

**Custody:** \*\*:\*.\*\*.\*\* \*\*/\*\*/\*\*

**Reason:**

**Comments:** Knife Sheath from subject collected by M.E. during autopsy, evidence bag #17

**Property Number:** 10112

**Item:** Clothing

**Owner Applied Nmbr:**

**Brand:**

**Model:**

**Year:** 0

**Quantity:** 2

**Meas:**

**Serial Nmbr:**

**Total Value:** \$0.00

**Color:**

**Owner:**

**Agency:** ADPS ARIZONA DEPT OF PUBLIC SAFETY

**Tag Number:** AR32

**Accum Amt Recov:** \$0.00

**Officer:** REED,A

**UCR:**

**UCR Status:**

**Local Status:** EVD

**Storage Location:** Envelope

**Crime Lab Number:**

**Status Date:** 01/27/20

**Date Released:** \*\*/\*\*/\*\*

**Date Recov/Rcvd:** \*\*/\*\*/\*\*

**Released By:**

**Amt Recovered:** \$0.00

**Released To:**

**Custody:** \*\*:\*.\*\*.\*\* \*\*/\*\*/\*\*

**Reason:**

**Comments:** Belts straps from subject collected by M.E. during autopsy, evidence bag #18

**Property Number:** 10113

**Item:** Bracelet

**Owner Applied Nmbr:**

**Brand:**

**Model:**

**Year:** 0 **Quantity:** 1  
**Meas:** **Serial Nbr:**  
**Total Value:** \$0.00 **Color:**  
**Owner:**  
**Agency:** ADPS ARIZONA DEPT OF PUBLIC SAFETY **Tag Number:** AR33  
**Accum Amt Recov:** \$0.00 **Officer:** REED,A  
**UCR:** **UCR Status:**  
**Local Status:** EVD **Storage Location:** Envelope  
**Crime Lab Number:** **Status Date:** 01/27/20  
**Date Released:** \*\*/\*\*/\*\* **Date Recov/Rcvd:** \*\*/\*\*/\*\*  
**Released By:** **Amt Recovered:** \$0.00  
**Released To:** **Custody:** \*\*:\*.\*\*:\*\* \*\*/\*\*/\*\*  
**Reason:**  
**Comments:** Leather bracelet from subjects right wrist collected by M.E. during autopsy, evidence bag #19  
**Property Number:** 10114  
**Item:** Bracelet **Owner Applied Nbr:**

**Brand:** **Model:**  
**Year:** 0 **Quantity:** 1  
**Meas:** **Serial Nbr:**  
**Total Value:** \$0.00 **Color:**  
**Owner:**  
**Agency:** ADPS ARIZONA DEPT OF PUBLIC SAFETY **Tag Number:** AR34  
**Accum Amt Recov:** \$0.00 **Officer:** REED,A  
**UCR:** **UCR Status:**  
**Local Status:** EVD **Storage Location:** Envelope  
**Crime Lab Number:** **Status Date:** 01/27/20  
**Date Released:** \*\*/\*\*/\*\* **Date Recov/Rcvd:** \*\*/\*\*/\*\*  
**Released By:** **Amt Recovered:** \$0.00  
**Released To:** **Custody:** \*\*:\*.\*\*:\*\* \*\*/\*\*/\*\*  
**Reason:**  
**Comments:** brown bracelet from subjects left wrist collected by M.E. during autopsy, evidence bag #20  
**Property Number:** 10115  
**Item:** Miscellaneous **Owner Applied Nbr:**

**Brand:** **Model:**  
**Year:** 0 **Quantity:** 2  
**Meas:** **Serial Nbr:**  
**Total Value:** \$0.00 **Color:**  
**Owner:**

**Agency:** ADPS ARIZONA DEPT OF PUBLIC SAFETY  
**Tag Number:** AR35  
**Accum Amt Recov:** \$0.00  
**Officer:** REED,A  
**UCR:**  
**UCR Status:**  
**Local Status:** EVD  
**Storage Location:** Envelope  
**Crime Lab Number:**  
**Status Date:** 01/27/20  
**Date Released:** \*\*/\*\*/\*\*  
**Date Recov/Rcvd:** \*\*/\*\*/\*\*  
**Released By:**  
**Amt Recovered:** \$0.00  
**Released To:**  
**Custody:** \*\*:\*.\*\*:\*\* \*\*/\*\*/\*\*  
**Reason:**  
**Comments:** pipe and yellow light from subject collected by M.E. during autopsy, evidence bag #21  
**Property Number:** 10116  
**Item:** Key  
**Owner Applied Nbr:**

**Brand:**  
**Model:**  
**Year:** 0  
**Quantity:** 1  
**Meas:**  
**Serial Nbr:**  
**Total Value:** \$0.00  
**Color:**  
**Owner:**  
**Agency:** ADPS ARIZONA DEPT OF PUBLIC SAFETY  
**Tag Number:** AR36  
**Accum Amt Recov:** \$0.00  
**Officer:** REED,A  
**UCR:**  
**UCR Status:**  
**Local Status:** EVD  
**Storage Location:** Envelope  
**Crime Lab Number:**  
**Status Date:** 01/27/20  
**Date Released:** \*\*/\*\*/\*\*  
**Date Recov/Rcvd:** \*\*/\*\*/\*\*  
**Released By:**  
**Amt Recovered:** \$0.00  
**Released To:**  
**Custody:** \*\*:\*.\*\*:\*\* \*\*/\*\*/\*\*  
**Reason:**  
**Comments:** 1 uncut key from subject collected by M.E. during autopsy, evidence bag #22  
**Property Number:** 10117  
**Item:** Nail  
**Owner Applied Nbr:**

**Brand:**  
**Model:**  
**Year:** 0  
**Quantity:** 10  
**Meas:**  
**Serial Nbr:**  
**Total Value:** \$0.00  
**Color:**  
**Owner:**  
**Agency:** ADPS ARIZONA DEPT OF PUBLIC SAFETY  
**Tag Number:** AR37  
**Accum Amt Recov:** \$0.00  
**Officer:** REED,A  
**UCR:**  
**UCR Status:**

**Local Status:** EVD  
**Crime Lab Number:**  
**Date Released:** \*\*/\*\*/\*\*  
**Released By:**  
**Released To:**  
**Reason:**  
**Comments:** Right hand and left hand finger nail clippings from subject collected by M.E. during autopsy, evidence bag #24

**Storage Location:** Envelope  
**Status Date:** 01/27/20  
**Date Recov/Rcvd:** \*\*/\*\*/\*\*  
**Amt Recovered:** \$0.00  
**Custody:** \*\*:\*\*:\*\* \*\*/\*\*/\*\*

**Property Number:** 10118  
**Item:** Bullet

**Owner Applied Nmbr:**

**Brand:**  
**Year:** 0  
**Meas:**  
**Total Value:** \$0.00  
**Owner:**  
**Agency:** ADPS ARIZONA DEPT OF PUBLIC SAFETY

**Model:**  
**Quantity:** 1  
**Serial Nmbr:**  
**Color:**  
**Tag Number:** AR38

**Accum Amt Recov:** \$0.00  
**UCR:**

**Officer:** REED,A  
**UCR Status:**

**Local Status:** EVD  
**Crime Lab Number:**  
**Date Released:** \*\*/\*\*/\*\*  
**Released By:**  
**Released To:**  
**Reason:**  
**Comments:** 1 Projectile from left back area of subject collected by M.E. during autopsy, evidence bag #25

**Storage Location:** Envelope  
**Status Date:** 01/27/20  
**Date Recov/Rcvd:** \*\*/\*\*/\*\*  
**Amt Recovered:** \$0.00  
**Custody:** \*\*:\*\*:\*\* \*\*/\*\*/\*\*

**Property Number:** 10119  
**Item:** Fingerprint

**Owner Applied Nmbr:**

**Brand:**  
**Year:** 0  
**Meas:**  
**Total Value:** \$0.00  
**Owner:**  
**Agency:** ADPS ARIZONA DEPT OF PUBLIC SAFETY

**Model:**  
**Quantity:** 1  
**Serial Nmbr:**  
**Color:**  
**Tag Number:** AR39

**Accum Amt Recov:** \$0.00  
**UCR:**

**Officer:** REED,A  
**UCR Status:**

**Local Status:** EVD  
**Crime Lab Number:**  
**Date Released:** \*\*/\*\*/\*\*

**Storage Location:** Envelope  
**Status Date:** 01/27/20  
**Date Recov/Rcvd:** \*\*/\*\*/\*\*

**Released By:** **Amt Recovered:** \$0.00  
**Released To:** **Custody:** \*\*:~::~~\*\* \*\*/\*\*/\*\*  
**Reason:**

**Comments:** fingerprints (10 prints) from subject collected by M.E. during autopsy, evidence bag #126  
**Property Number:** 10120  
**Item:** Bullet **Owner Applied Nmbr:**

**Brand:** **Model:**  
**Year:** 0 **Quantity:** 1  
**Meas:** **Serial Nmbr:**  
**Total Value:** \$0.00 **Color:**

**Owner:**  
**Agency:** ADPS ARIZONA DEPT OF PUBLIC SAFETY **Tag Number:** AR40  
**Accum Amt Recov:** \$0.00 **Officer:** REED,A  
**UCR:** **UCR Status:**

**Local Status:** EVD **Storage Location:** Envelope  
**Crime Lab Number:** **Status Date:** 01/27/20  
**Date Released:** \*\*/\*\*/\*\* **Date Recov/Rcvd:** \*\*/\*\*/\*\*

**Released By:** **Amt Recovered:** \$0.00  
**Released To:** **Custody:** \*\*:~::~~\*\* \*\*/\*\*/\*\*  
**Reason:**

**Comments:** One projectile form subjects right abdominal wall collected by M.E. during autopsy, evidence bag #27  
**Property Number:** 10121  
**Item:** Blood Sample **Owner Applied Nmbr:**

**Brand:** **Model:**  
**Year:** 0 **Quantity:** 1  
**Meas:** **Serial Nmbr:**  
**Total Value:** \$0.00 **Color:**

**Owner:**  
**Agency:** ADPS ARIZONA DEPT OF PUBLIC SAFETY **Tag Number:** AR41  
**Accum Amt Recov:** \$0.00 **Officer:** REED,A  
**UCR:** **UCR Status:**

**Local Status:** EVD **Storage Location:** Envelope  
**Crime Lab Number:** **Status Date:** 01/27/20  
**Date Released:** \*\*/\*\*/\*\* **Date Recov/Rcvd:** \*\*/\*\*/\*\*

**Released By:** **Amt Recovered:** \$0.00  
**Released To:** **Custody:** \*\*:~::~~\*\* \*\*/\*\*/\*\*  
**Reason:**

**Comments:** One blood blot from subject collected by M.E. during autopsy, evidence bag #28

**Property Number:** 10122

**Item:** Bullet

**Owner Applied Nmbr:**

**Brand:**

**Model:**

**Year:** 0

**Quantity:** 1

**Meas:**

**Serial Nmbr:**

**Total Value:** \$0.00

**Color:**

**Owner:**

**Agency:** ADPS ARIZONA DEPT OF PUBLIC SAFETY

**Tag Number:** AR42

**Accum Amt Recov:** \$0.00

**Officer:** REED,A

**UCR:**

**UCR Status:**

**Local Status:** EVD

**Storage Location:** Envelope

**Crime Lab Number:**

**Status Date:** 01/27/20

**Date Released:** \*\*/\*\*/\*\*

**Date Recov/Rcvd:** \*\*/\*\*/\*\*

**Released By:**

**Amt Recovered:** \$0.00

**Released To:**

**Custody:** \*\*.\*.\*.\* \*\*/\*\*/\*\*

**Reason:**

**Comments:** One projectile from subjects right back collected by M.E. during autopsy, evidence bag #29

**Property Number:** 10123

**Item:** Bullet

**Owner Applied Nmbr:**

**Brand:**

**Model:**

**Year:** 0

**Quantity:** 1

**Meas:**

**Serial Nmbr:**

**Total Value:** \$0.00

**Color:**

**Owner:**

**Agency:** ADPS ARIZONA DEPT OF PUBLIC SAFETY

**Tag Number:** AR43

**Accum Amt Recov:** \$0.00

**Officer:** REED,A

**UCR:**

**UCR Status:**

**Local Status:** EVD

**Storage Location:** Envelope

**Crime Lab Number:**

**Status Date:** 01/27/20

**Date Released:** \*\*/\*\*/\*\*

**Date Recov/Rcvd:** \*\*/\*\*/\*\*

**Released By:**

**Amt Recovered:** \$0.00

**Released To:**

**Custody:** \*\*.\*.\*.\* \*\*/\*\*/\*\*

**Reason:**

**Comments:** One projectile from subjects heart collected by M.E. during autopsy, evidence bag #30

**Property Number:** 10124

**Item:** Compact Disc

**Owner Applied Nmbr:**

**Brand:**  
**Year:** 0  
**Meas:**  
**Total Value:** \$0.00  
**Owner:**  
**Agency:** ADPS ARIZONA DEPT OF PUBLIC SAFETY  
**Accum Amt Recov:** \$0.00  
**UCR:**  
**Local Status:** EVD  
**Crime Lab Number:**  
**Date Released:** \*\*/\*\*/\*\*  
**Released By:**  
**Released To:**  
**Reason:**  
**Comments:** M.E. Autopsy photos  
**Property Number:** 9310  
**Item:** Glove

**Model:**  
**Quantity:** 1  
**Serial Nbr:**  
**Color:**  
**Tag Number:** AR44  
**Officer:** REED,A  
**UCR Status:**  
**Storage Location:** Envelope  
**Status Date:** 01/27/20  
**Date Recov/Rcvd:** \*\*/\*\*/\*\*  
**Amt Recovered:** \$0.00  
**Custody:** \*\*:\*.\*\*.\*\* \*\*/\*\*/\*\*

**Owner Applied Nbr:**

**Brand:**  
**Year:** 0  
**Meas:**  
**Total Value:** \$0.00  
**Owner:**  
**Agency:** ADPS ARIZONA DEPT OF PUBLIC SAFETY  
**Accum Amt Recov:** \$0.00  
**UCR:**  
**Local Status:** EVD  
**Crime Lab Number:**  
**Date Released:** \*\*/\*\*/\*\*  
**Released By:**  
**Released To:**  
**Reason:**  
**Comments:** 1 pair of black nitrile gloves  
**Property Number:** 9313  
**Item:** Casing

**Model:**  
**Quantity:** 2  
**Serial Nbr:**  
**Color:**  
**Tag Number:** MV1  
**Officer:** REED,A  
**UCR Status:**  
**Storage Location:** envelope  
**Status Date:** 01/21/20  
**Date Recov/Rcvd:** \*\*/\*\*/\*\*  
**Amt Recovered:** \$0.00  
**Custody:** \*\*:\*.\*\*.\*\* \*\*/\*\*/\*\*

**Owner Applied Nbr:**

**Brand:**  
**Year:** 0  
**Meas:**  
**Total Value:** \$0.00

**Model:**  
**Quantity:** 1  
**Serial Nbr:**  
**Color:**

**Owner:**

**Agency:** ADPS ARIZONA DEPT OF PUBLIC SAFETY

**Tag Number:** MV2

**Accum Amt Recov:** \$0.00

**Officer:** REED,A

**UCR:**

**UCR Status:**

**Local Status:** EVD

**Storage Location:** envelope

**Crime Lab Number:**

**Status Date:** 01/21/20

**Date Released:** \*\*/\*\*/\*\*

**Date Recov/Rcvd:** \*\*/\*\*/\*\*

**Released By:**

**Amt Recovered:** \$0.00

**Released To:**

**Custody:** \*\*:\*.\*\*:\*\* \*\*/\*\*/\*\*

**Reason:**

**Comments:** shell casing FC 9 mm Lugar

**Property Number:** 9315

**Item:** Casing

**Owner Applied Nmbr:**

**Brand:**

**Model:**

**Year:** 0

**Quantity:** 1

**Meas:**

**Serial Nmbr:**

**Total Value:** \$0.00

**Color:**

**Owner:**

**Agency:** ADPS ARIZONA DEPT OF PUBLIC SAFETY

**Tag Number:** MV3

**Accum Amt Recov:** \$0.00

**Officer:** REED,A

**UCR:**

**UCR Status:**

**Local Status:** EVD

**Storage Location:** envelope

**Crime Lab Number:**

**Status Date:** 01/21/20

**Date Released:** \*\*/\*\*/\*\*

**Date Recov/Rcvd:** \*\*/\*\*/\*\*

**Released By:**

**Amt Recovered:** \$0.00

**Released To:**

**Custody:** \*\*:\*.\*\*:\*\* \*\*/\*\*/\*\*

**Reason:**

**Comments:** shell casing FC 9mm Lugar

**Property Number:** 9316

**Item:** Casing

**Owner Applied Nmbr:**

**Brand:**

**Model:**

**Year:** 0

**Quantity:** 1

**Meas:**

**Serial Nmbr:**

**Total Value:** \$0.00

**Color:**

**Owner:**

**Agency:** ADPS ARIZONA DEPT OF PUBLIC SAFETY

**Tag Number:** MV4

**Accum Amt Recov:** \$0.00

**Officer:** REED,A



**UCR:**  
**Local Status:** EVD  
**Crime Lab Number:**  
**Date Released:** \*\*/\*\*/\*\*  
**Released By:**  
**Released To:**  
**Reason:**  
**Comments:** shell casing FC 9mm Lugar  
**Property Number:** 9318  
**Item:** Casing

**UCR Status:**  
**Storage Location:** envelope  
**Status Date:** 01/21/20  
**Date Recov/Rcvd:** \*\*/\*\*/\*\*  
**Amt Recovered:** \$0.00  
**Custody:** \*\*:\*.\*\*:\*\* \*\*/\*\*/\*\*  
**Owner Applied Nmbr:**

**Brand:**  
**Year:** 0  
**Meas:**  
**Total Value:** \$0.00  
**Owner:**  
**Agency:** ADPS ARIZONA DEPT OF PUBLIC SAFETY  
**Accum Amt Recov:** \$0.00

**Model:**  
**Quantity:** 1  
**Serial Nmbr:**  
**Color:**  
**Tag Number:** MV5  
**Officer:** REED,A

**UCR:**  
**Local Status:** EVD  
**Crime Lab Number:**  
**Date Released:** \*\*/\*\*/\*\*  
**Released By:**  
**Released To:**  
**Reason:**  
**Comments:** shell casing for FC 9mm Lugar  
**Property Number:** 9319  
**Item:** Casing

**UCR Status:**  
**Storage Location:** envelope  
**Status Date:** 01/21/20  
**Date Recov/Rcvd:** \*\*/\*\*/\*\*  
**Amt Recovered:** \$0.00  
**Custody:** \*\*:\*.\*\*:\*\* \*\*/\*\*/\*\*  
**Owner Applied Nmbr:**

**Brand:**  
**Year:** 0  
**Meas:**  
**Total Value:** \$0.00  
**Owner:**  
**Agency:** ADPS ARIZONA DEPT OF PUBLIC SAFETY  
**Accum Amt Recov:** \$0.00

**Model:**  
**Quantity:** 1  
**Serial Nmbr:**  
**Color:**  
**Tag Number:** MV6  
**Officer:** REED,A

**UCR:**  
**Local Status:** EVD  
**Crime Lab Number:**  
**Date Released:** \*\*/\*\*/\*\*

**UCR Status:**  
**Storage Location:** envelope  
**Status Date:** 01/21/20  
**Date Recov/Rcvd:** \*\*/\*\*/\*\*

**Released By:**

**Amt Recovered:** \$0.00

**Released To:**

**Custody:** \*\*:~::~~\*\* \*\*/\*\*/\*\*

**Reason:**

**Comments:** shell casing FC 9mm Lugar

**Property Number:** 9320

**Item:** Casing

**Owner Applied Nmbr:**

**Brand:**

**Model:**

**Year:** 0

**Quantity:** 1

**Meas:**

**Serial Nmbr:**

**Total Value:** \$0.00

**Color:**

**Owner:**

**Agency:** ADPS ARIZONA DEPT OF PUBLIC SAFETY

**Tag Number:** MV7

**Accum Amt Recov:** \$0.00

**Officer:** REED,A

**UCR:**

**UCR Status:**

**Local Status:** EVD

**Storage Location:** envelope

**Crime Lab Number:**

**Status Date:** 01/21/20

**Date Released:** \*\*/\*\*/\*\*

**Date Recov/Rcvd:** \*\*/\*\*/\*\*

**Released By:**

**Amt Recovered:** \$0.00

**Released To:**

**Custody:** \*\*:~::~~\*\* \*\*/\*\*/\*\*

**Reason:**

**Comments:** shell casing FC 9 mm lugar

**Property Number:** 9321

**Item:** Glove

**Owner Applied Nmbr:**

**Brand:**

**Model:**

**Year:** 0

**Quantity:** 4

**Meas:**

**Serial Nmbr:**

**Total Value:** \$0.00

**Color:**

**Owner:**

**Agency:** ADPS ARIZONA DEPT OF PUBLIC SAFETY

**Tag Number:** MV8

**Accum Amt Recov:** \$0.00

**Officer:** REED,A

**UCR:**

**UCR Status:**

**Local Status:** EVD

**Storage Location:** envelope

**Crime Lab Number:**

**Status Date:** 01/21/20

**Date Released:** \*\*/\*\*/\*\*

**Date Recov/Rcvd:** \*\*/\*\*/\*\*

**Released By:**

**Amt Recovered:** \$0.00

**Released To:**

**Custody:** \*\*:~::~~\*\* \*\*/\*\*/\*\*

**Reason:**

**Comments:** 4 loose gloves next to box

Property Number: 9323

Item: Package

Owner Applied Nmbr:

Brand:

Model:

Year: 0

Quantity: 1

Meas:

Serial Nmbr:

Total Value: \$0.00

Color:

Owner:

Agency: ADPS ARIZONA DEPT OF PUBLIC SAFETY

Tag Number: MV9

Accum Amt Recov: \$0.00

Officer: REED,A

UCR:

UCR Status:

Local Status: EVD

Storage Location: envelope

Crime Lab Number:

Status Date: 01/21/20

Date Released: \*\*/\*\*/\*\*

Date Recov/Rcvd: \*\*/\*\*/\*\*

Released By:

Amt Recovered: \$0.00

Released To:

Custody: \*\*:\*.\*\* \*\*/\*\*/\*\*

Reason:

Comments: ECG Electro bag

Property Number: 9324

Item: Sunglasses

Owner Applied Nmbr:

Brand:

Model:

Year: 0

Quantity: 1

Meas:

Serial Nmbr:

Total Value: \$0.00

Color:

Owner:

Agency: ADPS ARIZONA DEPT OF PUBLIC SAFETY

Tag Number: MV10

Accum Amt Recov: \$0.00

Officer: REED,A

UCR:

UCR Status:

Local Status: EVD

Storage Location: envelope

Crime Lab Number:

Status Date: 01/21/20

Date Released: \*\*/\*\*/\*\*

Date Recov/Rcvd: \*\*/\*\*/\*\*

Released By:

Amt Recovered: \$0.00

Released To:

Custody: \*\*:\*.\*\* \*\*/\*\*/\*\*

Reason:

Comments: sunglasses (kaenon)

Property Number: 9326

Item: Cane

Owner Applied Nmbr:

Brand:

Model:

**Year:** 0 **Quantity:** 1  
**Meas:** **Serial Nbr:**  
**Total Value:** \$0.00 **Color:**  
**Owner:**  
**Agency:** ADPS ARIZONA DEPT OF PUBLIC SAFETY **Tag Number:** MV11  
**Accum Amt Recov:** \$0.00 **Officer:** REED,A  
**UCR:** **UCR Status:**  
**Local Status:** EVD **Storage Location:** envelope  
**Crime Lab Number:** **Status Date:** 01/21/20  
**Date Released:** \*\*/\*\*/\*\* **Date Recov/Rcvd:** \*\*/\*\*/\*\*  
**Released By:** **Amt Recovered:** \$0.00  
**Released To:** **Custody:** \*\*:\*\*:\*\* \*\*/\*\*/\*\*  
**Reason:**  
**Comments:** approximately 5 ft tall cane made from rebar. attached is a pouch with two green meditation balls and a blue flashlight.

**Property Number:** 9327  
**Item:** Disk Drive **Owner Applied Nbr:**

**Brand:** **Model:**  
**Year:** 0 **Quantity:** 1  
**Meas:** **Serial Nbr:**  
**Total Value:** \$0.00 **Color:**  
**Owner:**  
**Agency:** ADPS ARIZONA DEPT OF PUBLIC SAFETY **Tag Number:** MVA.1  
**Accum Amt Recov:** \$0.00 **Officer:** REED,A  
**UCR:** **UCR Status:**  
**Local Status:** EVD **Storage Location:** envelope  
**Crime Lab Number:** **Status Date:** 01/21/20  
**Date Released:** \*\*/\*\*/\*\* **Date Recov/Rcvd:** \*\*/\*\*/\*\*  
**Released By:** **Amt Recovered:** \$0.00  
**Released To:** **Custody:** \*\*:\*\*:\*\* \*\*/\*\*/\*\*  
**Reason:**  
**Comments:** L3 disk drive from dashcam of vehicle #15

**Property Number:** 9328  
**Item:** Paper **Owner Applied Nbr:**

**Brand:** **Model:**  
**Year:** 0 **Quantity:** 1  
**Meas:** **Serial Nbr:**  
**Total Value:** \$0.00 **Color:**

**Owner:**  
**Agency:** ADPS ARIZONA DEPT OF PUBLIC SAFETY      **Tag Number:** MVA.2  
**Accum Amt Recov:** \$0.00      **Officer:** REED,A  
**UCR:**      **UCR Status:**  
**Local Status:** EVD      **Storage Location:** envelope  
**Crime Lab Number:**      **Status Date:** 01/21/20  
**Date Released:** \*\*/\*\*/\*\*      **Date Recov/Rcvd:** \*\*/\*\*/\*\*  
**Released By:**      **Amt Recovered:** \$0.00  
**Released To:**      **Custody:** \*\*:\*\*.\*\*. \*\*/\*\*/\*\*  
**Reason:**  
**Comments:** EKG print out found on front seat of vehicle #15  
**Property Number:** 9329  
**Item:** Disk Drive      **Owner Applied Nmbr:**  
  
**Brand:**      **Model:**  
**Year:** 0      **Quantity:** 1  
**Meas:**      **Serial Nmbr:**  
**Total Value:** \$0.00      **Color:**  
**Owner:**  
**Agency:** ADPS ARIZONA DEPT OF PUBLIC SAFETY      **Tag Number:** MVB.1  
**Accum Amt Recov:** \$0.00      **Officer:** REED,A  
**UCR:**      **UCR Status:**  
**Local Status:** EVD      **Storage Location:** envelope  
**Crime Lab Number:**      **Status Date:** 01/21/20  
**Date Released:** \*\*/\*\*/\*\*      **Date Recov/Rcvd:** \*\*/\*\*/\*\*  
**Released By:**      **Amt Recovered:** \$0.00  
**Released To:**      **Custody:** \*\*:\*\*.\*\*. \*\*/\*\*/\*\*  
**Reason:**  
**Comments:** PNY 32 GB SD card from dash cam of vehicle 7  
**Property Number:** 9330  
**Item:** Drivers License      **Owner Applied Nmbr:**  
  
**Brand:**      **Model:**  
**Year:** 0      **Quantity:** 1  
**Meas:**      **Serial Nmbr:**  
**Total Value:** \$0.00      **Color:**  
**Owner:**  
**Agency:** ADPS ARIZONA DEPT OF PUBLIC SAFETY      **Tag Number:** MVB.2  
**Accum Amt Recov:** \$0.00      **Officer:** REED,A

**UCR:**  
**Local Status:** EVD  
**Crime Lab Number:**  
**Date Released:** \*\*/\*\*/\*\*  
**Released By:**  
**Released To:**  
**Reason:**  
**Comments:** Oregon Driver's license [REDACTED] Jonathan David Messare  
**Property Number:** 9331  
**Item:** Glove

**UCR Status:**  
**Storage Location:** envelope  
**Status Date:** 01/21/20  
**Date Recov/Rcvd:** \*\*/\*\*/\*\*  
**Amt Recovered:** \$0.00  
**Custody:** \*\*:\*\*:\*\* \*\*/\*\*/\*\*

**Owner Applied Nmbr:**

**Brand:**  
**Year:** 0  
**Meas:**  
**Total Value:** \$0.00  
**Owner:**  
**Agency:** ADPS ARIZONA DEPT OF PUBLIC SAFETY

**Model:**  
**Quantity:** 2  
**Serial Nmbr:**  
**Color:**

**Tag Number:** MVB.3

**Accum Amt Recov:** \$0.00  
**Officer:** REED,A

**UCR:**  
**Local Status:** EVD  
**Crime Lab Number:**  
**Date Released:** \*\*/\*\*/\*\*  
**Released By:**  
**Released To:**  
**Reason:**  
**Comments:** 1 pair of black nitrile gloves  
**Property Number:** 9332  
**Item:** Disk Drive

**UCR Status:**  
**Storage Location:** envelope  
**Status Date:** 01/21/20  
**Date Recov/Rcvd:** \*\*/\*\*/\*\*  
**Amt Recovered:** \$0.00  
**Custody:** \*\*:\*\*:\*\* \*\*/\*\*/\*\*

**Owner Applied Nmbr:**

**Brand:**  
**Year:** 0  
**Meas:**  
**Total Value:** \$0.00  
**Owner:**  
**Agency:** ADPS ARIZONA DEPT OF PUBLIC SAFETY

**Model:**  
**Quantity:** 1  
**Serial Nmbr:**  
**Color:**

**Tag Number:** MVC.1

**Accum Amt Recov:** \$0.00  
**Officer:** REED,A

**UCR:**  
**Local Status:** EVD  
**Crime Lab Number:**  
**Date Released:** \*\*/\*\*/\*\*

**UCR Status:**  
**Storage Location:** envelope  
**Status Date:** 01/21/20  
**Date Recov/Rcvd:** \*\*/\*\*/\*\*

<b>Released By:</b>	<b>Amt Recovered:</b> \$0.00
<b>Released To:</b>	<b>Custody:</b> **:~::~~** **/**/**
<b>Reason:</b>	
<b>Comments:</b> L3 disk drive from the dash cam of vehicle 14 serial number cf0231739	
<b>Property Number:</b> 9333	
<b>Item:</b> Sheet	<b>Owner Applied Nmbr:</b>
<b>Brand:</b>	<b>Model:</b>
<b>Year:</b> 0	<b>Quantity:</b> 1
<b>Meas:</b>	<b>Serial Nmbr:</b>
<b>Total Value:</b> \$0.00	<b>Color:</b>
<b>Owner:</b>	
<b>Agency:</b> ADPS ARIZONA DEPT OF PUBLIC SAFETY	<b>Tag Number:</b> MV12.1
<b>Accum Amt Recov:</b> \$0.00	<b>Officer:</b> REED,A
<b>UCR:</b>	<b>UCR Status:</b>
<b>Local Status:</b> EVD	<b>Storage Location:</b> box
<b>Crime Lab Number:</b>	<b>Status Date:</b> 01/21/20
<b>Date Released:</b> **/**/**	<b>Date Recov/Rcvd:</b> **/**/**
<b>Released By:</b>	<b>Amt Recovered:</b> \$0.00
<b>Released To:</b>	<b>Custody:</b> **:~::~~** **/**/**
<b>Reason:</b>	
<b>Comments:</b> White sheet covered deceased. Appeared to have blood stain on it.	
<b>Property Number:</b> 9334	
<b>Item:</b> Cellular Phone	<b>Owner Applied Nmbr:</b>
<b>Brand:</b>	<b>Model:</b>
<b>Year:</b> 0	<b>Quantity:</b> 1
<b>Meas:</b>	<b>Serial Nmbr:</b>
<b>Total Value:</b> \$0.00	<b>Color:</b>
<b>Owner:</b>	
<b>Agency:</b> ADPS ARIZONA DEPT OF PUBLIC SAFETY	<b>Tag Number:</b> GL1
<b>Accum Amt Recov:</b> \$0.00	<b>Officer:</b> REED,A
<b>UCR:</b>	<b>UCR Status:</b>
<b>Local Status:</b> EVD	<b>Storage Location:</b> envelope
<b>Crime Lab Number:</b>	<b>Status Date:</b> 01/21/20
<b>Date Released:</b> **/**/**	<b>Date Recov/Rcvd:</b> **/**/**
<b>Released By:</b>	<b>Amt Recovered:</b> \$0.00
<b>Released To:</b>	<b>Custody:</b> **:~::~~** **/**/**
<b>Reason:</b>	
<b>Comments:</b> Cat phone, black in color with charging cable	

**Property Number:** 9335

**Item:** Ammunition

**Owner Applied Nmbr:**

**Brand:**

**Model:**

**Year:** 0

**Quantity:** 16

**Meas:**

**Serial Nmbr:**

**Total Value:** \$0.00

**Color:**

**Owner:**

**Agency:** ADPS ARIZONA DEPT OF PUBLIC SAFETY

**Tag Number:** AR8

**Accum Amt Recov:** \$0.00

**Officer:** REED,A

**UCR:**

**UCR Status:**

**Local Status:** EVD

**Storage Location:** envelope

**Crime Lab Number:**

**Status Date:** 01/21/20

**Date Released:** \*\*/\*\*/\*\*

**Date Recov/Rcvd:** \*\*/\*\*/\*\*

**Released By:**

**Amt Recovered:** \$0.00

**Released To:**

**Custody:** \*\*:\*.\*\* \*\*/\*\*/\*\*

**Reason:**

**Comments:** 16 9mm rounds FC Lugar plus one Glock 17 round magazine (magazine #3, bottom magazine pouch)

**Property Number:** 9336

**Item:** Ammunition

**Owner Applied Nmbr:**

**Brand:**

**Model:**

**Year:** 0

**Quantity:** 13

**Meas:**

**Serial Nmbr:**

**Total Value:** \$0.00

**Color:**

**Owner:**

**Agency:** ADPS ARIZONA DEPT OF PUBLIC SAFETY

**Tag Number:** AR2

**Accum Amt Recov:** \$0.00

**Officer:** REED,A

**UCR:**

**UCR Status:**

**Local Status:** EVD

**Storage Location:** envelope

**Crime Lab Number:**

**Status Date:** 01/21/20

**Date Released:** \*\*/\*\*/\*\*

**Date Recov/Rcvd:** \*\*/\*\*/\*\*

**Released By:**

**Amt Recovered:** \$0.00

**Released To:**

**Custody:** \*\*:\*.\*\* \*\*/\*\*/\*\*

**Reason:**

**Comments:** 13 9mm FC Lugar and one 17 round Glock Magazine

**Property Number:** 9337

**Item:** Ammunition

**Owner Applied Nmbr:**



**Brand:** **Model:**  
**Year:** 0 **Quantity:** 16  
**Meas:** **Serial Nbr:**  
**Total Value:** \$0.00 **Color:**  
**Owner:**  
**Agency:** ADPS ARIZONA DEPT OF PUBLIC SAFETY **Tag Number:** AR3  
**Accum Amt Recov:** \$0.00 **Officer:** REED,A  
**UCR:** **UCR Status:**  
**Local Status:** EVD **Storage Location:** envelope  
**Crime Lab Number:** **Status Date:** 01/21/20  
**Date Released:** \*\*/\*\*/\*\* **Date Recov/Rcvd:** \*\*/\*\*/\*\*  
**Released By:** **Amt Recovered:** \$0.00  
**Released To:** **Custody:** \*\*:\*.\*\*:\*\* \*\*/\*\*/\*\*  
**Reason:**  
**Comments:** 16 FC 9mm Lugar ammunition and one 17 round Glock Magazine (magazine #2 in pouch on belt.)  
**Property Number:** 9338  
**Item:** Ammunition **Owner Applied Nbr:**

**Brand:** **Model:**  
**Year:** 0 **Quantity:** 16  
**Meas:** **Serial Nbr:**  
**Total Value:** \$0.00 **Color:**  
**Owner:**  
**Agency:** ADPS ARIZONA DEPT OF PUBLIC SAFETY **Tag Number:** AR4  
**Accum Amt Recov:** \$0.00 **Officer:** REED,A  
**UCR:** **UCR Status:**  
**Local Status:** EVD **Storage Location:** envelope  
**Crime Lab Number:** **Status Date:** 01/21/20  
**Date Released:** \*\*/\*\*/\*\* **Date Recov/Rcvd:** \*\*/\*\*/\*\*  
**Released By:** **Amt Recovered:** \$0.00  
**Released To:** **Custody:** \*\*:\*.\*\*:\*\* \*\*/\*\*/\*\*  
**Reason:**  
**Comments:** 16 9mm FC Lugar and 17 round Glock magazine ( magazine number 3)  
**Property Number:** 9339  
**Item:** Ammunition **Owner Applied Nbr:**

**Brand:** **Model:**  
**Year:** 0 **Quantity:** 16  
**Meas:** **Serial Nbr:**  
**Total Value:** \$0.00 **Color:**

**Owner:**

**Agency:** ADPS ARIZONA DEPT OF PUBLIC SAFETY

**Tag Number:** AR7

**Accum Amt Recov:** \$0.00

**Officer:** REED,A

**UCR:**

**UCR Status:**

**Local Status:** EVD

**Storage Location:** envelope

**Crime Lab Number:**

**Status Date:** 01/21/20

**Date Released:** \*\*/\*\*/\*\*

**Date Recov/Rcvd:** \*\*/\*\*/\*\*

**Released By:**

**Amt Recovered:** \$0.00

**Released To:**

**Custody:** \*\*:\*.\*\*.\*\* \*\*/\*\*/\*\*

**Reason:**

**Comments:** 16 9mm FC Lugar and 1 17 round Glock magazine

**Property Number:** 9340

**Item:** Ammunition

**Owner Applied Nmbr:**

**Brand:**

**Model:**

**Year:** 0

**Quantity:** 15

**Meas:**

**Serial Nmbr:**

**Total Value:** \$0.00

**Color:**

**Owner:**

**Agency:** ADPS ARIZONA DEPT OF PUBLIC SAFETY

**Tag Number:** AR6

**Accum Amt Recov:** \$0.00

**Officer:** REED,A

**UCR:**

**UCR Status:**

**Local Status:** EVD

**Storage Location:** envelope

**Crime Lab Number:**

**Status Date:** 01/21/20

**Date Released:** \*\*/\*\*/\*\*

**Date Recov/Rcvd:** \*\*/\*\*/\*\*

**Released By:**

**Amt Recovered:** \$0.00

**Released To:**

**Custody:** \*\*:\*.\*\*.\*\* \*\*/\*\*/\*\*

**Reason:**

**Comments:** 15 9mm FC Lugar and one 17 round Glock Magazine

**Property Number:** 9341

**Item:** Gun

**Owner Applied Nmbr:**

**Brand:**

**Model:**

**Year:** 0

**Quantity:** 1

**Meas:**

**Serial Nmbr:**

**Total Value:** \$0.00

**Color:**

**Owner:**

**Agency:** ADPS ARIZONA DEPT OF PUBLIC SAFETY

**Tag Number:** AR1

**Accum Amt Recov:** \$0.00

**Officer:** REED,A

**UCR:**  
**Local Status:** EVD  
**Crime Lab Number:**  
**Date Released:** \*\*/\*\*/\*\*  
**Released By:**  
**Released To:**  
**Reason:**  
**Comments:** Glock 9mm with stream light TLR1 attachment serial # BEAG443  
**Property Number:** 9342  
**Item:** Gun

**UCR Status:**  
**Storage Location:** box  
**Status Date:** 01/21/20  
**Date Recov/Rcvd:** \*\*/\*\*/\*\*  
**Amt Recovered:** \$0.00  
**Custody:** \*\*.\*:\*\* \*\*/\*\*/\*\*

**Owner Applied Nmbr:**

**Brand:**  
**Year:** 0  
**Meas:**  
**Total Value:** \$0.00  
**Owner:**  
**Agency:** ADPS ARIZONA DEPT OF PUBLIC SAFETY

**Model:**  
**Quantity:** 1  
**Serial Nmbr:**  
**Color:**

**Tag Number:** AR5

**Accum Amt Recov:** \$0.00  
**UCR:**  
**Local Status:** EVD  
**Crime Lab Number:**  
**Date Released:** \*\*/\*\*/\*\*  
**Released By:**  
**Released To:**  
**Reason:**  
**Comments:** Glock 9mm handgun serial #BEAG461  
**Property Number:** 9343  
**Item:** Knife

**UCR Status:**  
**Storage Location:** box  
**Status Date:** 01/21/20  
**Date Recov/Rcvd:** \*\*/\*\*/\*\*  
**Amt Recovered:** \$0.00  
**Custody:** \*\*.\*:\*\* \*\*/\*\*/\*\*

**Officer:** REED,A  
**Owner Applied Nmbr:**

**Brand:**  
**Year:** 0  
**Meas:**  
**Total Value:** \$0.00  
**Owner:**  
**Agency:** ADPS ARIZONA DEPT OF PUBLIC SAFETY

**Model:**  
**Quantity:** 1  
**Serial Nmbr:**  
**Color:**

**Tag Number:** MVB.4

**Accum Amt Recov:** \$0.00  
**UCR:**  
**Local Status:** EVD  
**Crime Lab Number:**  
**Date Released:** \*\*/\*\*/\*\*

**UCR Status:**  
**Storage Location:** box  
**Status Date:** 01/21/20  
**Date Recov/Rcvd:** \*\*/\*\*/\*\*

**Officer:** REED,A

<b>Released By:</b>	<b>Amt Recovered:</b> \$0.00
<b>Released To:</b>	<b>Custody:</b> **:~::~~** **/**/**
<b>Reason:</b>	
<b>Comments:</b> Red buck knife with wood handle 5" blade	
<b>Property Number:</b> 9344	
<b>Item:</b> Sheet	<b>Owner Applied Nmbr:</b>
<b>Brand:</b>	<b>Model:</b>
<b>Year:</b> 0	<b>Quantity:</b> 1
<b>Meas:</b>	<b>Serial Nmbr:</b>
<b>Total Value:</b> \$0.00	<b>Color:</b>
<b>Owner:</b>	
<b>Agency:</b> ADPS ARIZONA DEPT OF PUBLIC SAFETY	<b>Tag Number:</b> MVB.7
<b>Accum Amt Recov:</b> \$0.00	<b>Officer:</b> REED,A
<b>UCR:</b>	<b>UCR Status:</b>
<b>Local Status:</b> EVD	<b>Storage Location:</b> box
<b>Crime Lab Number:</b>	<b>Status Date:</b> 01/21/20
<b>Date Released:</b> **/**/**	<b>Date Recov/Rcvd:</b> **/**/**
<b>Released By:</b>	<b>Amt Recovered:</b> \$0.00
<b>Released To:</b>	<b>Custody:</b> **:~::~~** **/**/**
<b>Reason:</b>	
<b>Comments:</b> White sheet with wrapped in it MVB.4-7	
<b>Property Number:</b> 9346	
<b>Item:</b> Ax	<b>Owner Applied Nmbr:</b>
<b>Brand:</b>	<b>Model:</b>
<b>Year:</b> 0	<b>Quantity:</b> 1
<b>Meas:</b>	<b>Serial Nmbr:</b>
<b>Total Value:</b> \$0.00	<b>Color:</b>
<b>Owner:</b>	
<b>Agency:</b> ADPS ARIZONA DEPT OF PUBLIC SAFETY	<b>Tag Number:</b> MVB.5
<b>Accum Amt Recov:</b> \$0.00	<b>Officer:</b> REED,A
<b>UCR:</b>	<b>UCR Status:</b>
<b>Local Status:</b> EVD	<b>Storage Location:</b> box
<b>Crime Lab Number:</b>	<b>Status Date:</b> 01/21/20
<b>Date Released:</b> **/**/**	<b>Date Recov/Rcvd:</b> **/**/**
<b>Released By:</b>	<b>Amt Recovered:</b> \$0.00
<b>Released To:</b>	<b>Custody:</b> **:~::~~** **/**/**
<b>Reason:</b>	
<b>Comments:</b> hatchet with case found in rear cargo area of vehicle 7, wrapped in a white blanket	

**Property Number:** 9347

**Item:** Sword

**Owner Applied Nmbr:**

**Brand:**

**Year:** 0

**Meas:**

**Total Value:** \$0.00

**Owner:**

**Agency:** ADPS ARIZONA DEPT OF PUBLIC SAFETY

**Model:**

**Quantity:** 1

**Serial Nmbr:**

**Color:**

**Tag Number:** MVB.6

**Accum Amt Recov:** \$0.00

**UCR:**

**Local Status:** EVD

**Crime Lab Number:**

**Date Released:** \*\*/\*\*/\*\*

**Released By:**

**Released To:**

**Reason:**

**Comments:** sword located in the rear cargo area of vehicle 7, wrapped in a white blanket. Dried blood on blade. 24" in length

**Officer:** REED,A

**UCR Status:**

**Storage Location:** box

**Status Date:** 01/21/20

**Date Recov/Rcvd:** \*\*/\*\*/\*\*

**Amt Recovered:** \$0.00

**Custody:** \*\*.\*.\* \*\*/\*\*/\*\*

**Name Involvements:**

**Suspect :** 49771

**Last:** MESSARE

**First:** JONATHAN

**Mid:** DAVID

**DOB:** [REDACTED]

**Dr Lic:** [REDACTED]

**Address:** [REDACTED]

**Race:** W      **Sex:** M

**Phone:**

**City:** [REDACTED]

THIS CASE WAS PREVIOUSLY DECLINED OR RETURNED FOR FURTHER ACTION

Please Note: CHARGING REQUESTS RESULTING FROM AN ARREST MUST INCLUDE ALL BOOKING CHARGES AND STATUTES ON THIS FORM (please list in same order as suspect was booked)

### CHARGING REQUEST

TO: Coconino County Attorney  
DR# **I20003903**

FROM: (Officer/Agency/ID#) **A. Reed #7325 AZDPS**  
OFFENSE DATE: **01/20/2020** CHARGING REQUEST DATE: \_\_\_\_\_

ARREST DATE: \_\_\_\_\_ or NEVER ARRESTED FOR THIS OFFENSE:

**\*\*CHECK ALL THAT APPLY\*\***

- CCA CRIME       JUVENILE CCA CRIME       GANG RELATED       JOINT INVESTIGATION WITH CPS
- SWS CRIME       VIOLENT OFFENDER       VIOLATION - ORDER OF PROTECTION

SUSPECT NAME (Last, First, Middle) INVOLVED PARTY (DECEASED): , Jonathan David Messare							SUSPECT'S RESIDENCE ADDRESS [REDACTED] City [REDACTED] ST [REDACTED] Zip [REDACTED]				
DOB	HGT	WGT	SEX	HAIR	EYES	RACE	SSN	DL # and STATE	SID #	FBI #	

Suspect is (check box):  IN CUSTODY       NOT in custody

Charge Codes (PLEASE INDICATE IF DV)	Counts	Charge Codes (PLEASE INDICATE IF DV)	Counts
OFFICER INVOLVED SHOOTING	M <input type="checkbox"/> F <input type="checkbox"/>		M <input type="checkbox"/> F <input type="checkbox"/>
	M <input type="checkbox"/> F <input type="checkbox"/>		M <input type="checkbox"/> F <input type="checkbox"/>
	M <input type="checkbox"/> F <input type="checkbox"/>		M <input type="checkbox"/> F <input type="checkbox"/>

SUSPECT NAME (Last, First, Middle)							SUSPECT'S RESIDENCE ADDRESS				
							City [REDACTED] ST [REDACTED] Zip [REDACTED]				
DOB	HGT	WGT	SEX	HAIR	EYES	RACE	SSN	DL # and STATE	SID #	FBI #	

Suspect is (check box):  IN CUSTODY       NOT in custody

Charge Codes (PLEASE INDICATE IF DV)	Counts	Charge Codes (PLEASE INDICATE IF DV)	Counts
	M <input type="checkbox"/> F <input type="checkbox"/>		M <input type="checkbox"/> F <input type="checkbox"/>
	M <input type="checkbox"/> F <input type="checkbox"/>		M <input type="checkbox"/> F <input type="checkbox"/>
	M <input type="checkbox"/> F <input type="checkbox"/>		M <input type="checkbox"/> F <input type="checkbox"/>

(Use Additional Sheets for more suspects, if necessary)

VICTIM NAME (Last, First, Middle) INVOLVED OFFICER: , Casey Pelletier							VICTIM'S MAILING ADDRESS [REDACTED] City [REDACTED] ST [REDACTED] Zip [REDACTED]				
DOB	HGT	WGT	SEX	HAIR	EYES	RACE	SSN	Home Phone	Work Phone	Other Phone	

VICTIM NAME (Last, First, Middle) INVOLVED OFFICER: , William Hunt							VICTIM'S MAILING ADDRESS [REDACTED] City [REDACTED] ST [REDACTED] Zip [REDACTED]				
DOB	HGT	WGT	SEX	HAIR	EYES	RACE	SSN	Home Phone	Work Phone	Other Phone	

(Use Additional Sheets for more victims, if necessary)

COMMENTS: \_\_\_\_\_

Revised 08/05/2014

DPS000047

## INFORMATION REQUIRED WITH CHARGING REQUEST

IF ANY OF THE CHARGES ARE LISTED BELOW YOU **MUST** INCLUDE THE INFORMATION REQUESTED BEFORE WE CAN REVIEW THE CHARGING REQUEST. PLEASE MARK THE APPROPRIATE BOXES INDICATING THAT THE INFORMATION IS INCLUDED IN THE CHARGING REQUEST.

**CHARGE CATEGORY:** \_\_\_\_\_ **INFORMATION NEEDED:** \_\_\_\_\_

- EVERY CASE:**
- Criminal History
  - Audio/Video Tapes (**complete list on reverse side**)
  - Witness statements
  - All supplements
  - All photos (2 copies OR via CDROM OR via email)
  - 911/dispatch tapes (check if at least requested but not received at time of charging request)

- CHILD CRIMES:** If a CCA involving a parent guardian or custodian as defined in: ARS 13-3623 (Child Abuse), 13-3601 (Fel DV), 13-1404 (Sex Abuse), 13-1405 (Sex Con w/Minor), 13-1406 (Sex Assault-Min), 13-1410 (Child Molest), 13-1417 (Cont. Sex Abuse of Child), **or** any other act which may result in *serious harm, injury or death* to a child; 13-3506 (Indecent exposure to 0-14 yr old); 13-1403 (public sex indecency -minor); 13-3019 (surrept. photo.); 13-3212 (child prostitution); 13-3506 (furnishing harmful items); 13-3552 (Com. Sex Exploit); 13-3553 (Sex Exploit); 13-3556 (admit minor to pub disp); 13-3620 (duty to report abuse):
- Check box on front of **Charging Request Form**
  - Joint investigation to be conducted with CPS; must be documented in DR. *If no joint investigation done, officer must document in DR why joint investigation not conducted.*
  - CD and summary report of Safe Child interview
  - Was law enforcement contacted by CPS? *G Yes G No; if No, did law enforcement contact CPS? G Yes G No;*
  - Is officer requesting that charges be filed? *G Yes G No*
  - Please check other boxes in categories Agg Assault/DV/Drug/Sex Assault, etc. where applicable

- AGGRAVATED DUI:**
- KO
  - If Suspect's license is out of state:** Certified Copy of MVD from state of residence.
  - If Agg. DUI w/minor** - List Victim(s) on page 1 and include Victim Notification Sheet(s) with date of birth of minor
  - Blood and/or UA Lab Results
  - Admin per se / Implied consent form
  - DUI Drugs: DRE report
  - Search warrant and Return / L.E. Phlebotomist's Blood Draw Report
  - 911/dispatch tapes if phone/anonymous caller/report

- DRUGS:**
- Flash test or lab results
  - Indicate in report what paraphernalia was used for
  - Approximate weight of drugs

- VIOLATION OF ORDERS OF PROTECTION or AGG HARASSMENT or DV AGG ASSAULT or AGG ASSAULT or AGG DV**
- Certified copy of Order of Protection or IAH and Affidavit of Service upon Suspect (*If VOP or AGG HARASSMENT*)
  - Certified copy of prior DV convictions (after 1/1/99) (*If DV case*)
  - Medical Records for Victim
  - Victim Notification Sheet completed

- SEX CRIMES:**
- All medical records/photos regarding offense
  - SAN/SART records
  - Safe-child records
  - All physical evidence has been forwarded to crime lab for analysis

- PROPERTY CRIMES:**
- List and value amount of all property involved
  - Restitution amount
  - List all recovered evidence

- FORGERY/CREDIT CARD:**
- Copies of all checks/credit card receipts in issue
  - Verification from bank/check/credit card holder of forgery

**Submitting Officer's Name:** (please print) \_\_\_\_\_ **Date:** \_\_\_\_\_

REVISED 10/27/09

# DESCRIBE ALL AUDIO/VIDEO/CD-ROM's SUBMITTED

**VIDEOS:**

DPS000048



- |    |     |
|----|-----|
| 1. | 8.  |
| 2. | 9.  |
| 3. | 10. |
| 4. | 11. |
| 5. | 12. |
| 6. | 13. |
| 7. | 14. |

**AUDIO CASSETTES:**

- |    |     |
|----|-----|
| 1. | 8.  |
| 2. | 9.  |
| 3. | 10. |
| 4. | 11. |
| 5. | 12. |
| 6. | 13. |
| 7. | 14. |

**CD-ROM's:**

- |    |     |
|----|-----|
| 1. | 8.  |
| 2. | 9.  |
| 3. | 10. |
| 4. | 11. |
| 5. | 12. |
| 6. | 13. |
| 7. | 14. |

Submitting Officer's Signature \_\_\_\_\_

Date \_\_\_\_\_

Acknowledging Charging attorney's signature \_\_\_\_\_

Date \_\_\_\_\_

THIS CASE WAS PREVIOUSLY DECLINED OR RETURNED FOR FURTHER ACTION

Please Note: CHARGING REQUESTS RESULTING FROM AN ARREST MUST INCLUDE ALL BOOKING CHARGES AND STATUTES ON THIS FORM (please list in same order as suspect was booked)

### CHARGING REQUEST

TO: Coconino County Attorney

FROM: (Officer/Agency/ID#) **A. Reed #7325 AZDPS**

DR# **I20003903**

OFFENSE DATE: **01/20/2020**

CHARGING REQUEST DATE: \_\_\_\_\_

ARREST DATE: \_\_\_\_\_ or NEVER ARRESTED FOR THIS OFFENSE:

**\*\*CHECK ALL THAT APPLY\*\***

- CCA CRIME       JUVENILE CCA CRIME       GANG RELATED       JOINT INVESTIGATION WITH CPS
- SWS CRIME       VIOLENT OFFENDER       VIOLATION - ORDER OF PROTECTION

SUSPECT NAME (Last, First, Middle) INVOLVED PARTY (DECEASED): , Jonathan David Messare							SUSPECT'S RESIDENCE ADDRESS [REDACTED] City _____ ST _____ Zip _____				
DOB	HGT	WGT	SEX	HAIR	EYES	RACE	SSN	DL # and STATE	SID #	FBI #	

Suspect is (check box):  IN CUSTODY       NOT in custody

Charge Codes (PLEASE INDICATE IF DV)	Counts	Charge Codes (PLEASE INDICATE IF DV)	Counts
OFFICER INVOLVED SHOOTING	M <input type="checkbox"/> F <input type="checkbox"/>		M <input type="checkbox"/> F <input type="checkbox"/>
	M <input type="checkbox"/> F <input type="checkbox"/>		M <input type="checkbox"/> F <input type="checkbox"/>
	M <input type="checkbox"/> F <input type="checkbox"/>		M <input type="checkbox"/> F <input type="checkbox"/>

SUSPECT NAME (Last, First, Middle)							SUSPECT'S RESIDENCE ADDRESS				
							City _____ ST _____ Zip _____				
DOB	HGT	WGT	SEX	HAIR	EYES	RACE	SSN	DL # and STATE	SID #	FBI #	

Suspect is (check box):  IN CUSTODY       NOT in custody

Charge Codes (PLEASE INDICATE IF DV)	Counts	Charge Codes (PLEASE INDICATE IF DV)	Counts
	M <input type="checkbox"/> F <input type="checkbox"/>		M <input type="checkbox"/> F <input type="checkbox"/>
	M <input type="checkbox"/> F <input type="checkbox"/>		M <input type="checkbox"/> F <input type="checkbox"/>
	M <input type="checkbox"/> F <input type="checkbox"/>		M <input type="checkbox"/> F <input type="checkbox"/>

(Use Additional Sheets for more suspects, if necessary)

VICTIM NAME (Last, First, Middle) Harrell, Cheryle Lynne							VICTIM'S MAILING ADDRESS [REDACTED] City _____ ST _____ Zip _____				
DOB	HGT	WGT	SEX	HAIR	EYES	RACE	SSN	Home Phone	Work Phone	Other Phone	
[REDACTED]			F			W		[REDACTED]			

VICTIM NAME (Last, First, Middle)							VICTIM'S MAILING ADDRESS				
							City _____ ST _____ Zip _____				
DOB	HGT	WGT	SEX	HAIR	EYES	RACE	SSN	Home Phone	Work Phone	Other Phone	

(Use Additional Sheets for more victims, if necessary)

COMMENTS: \_\_\_\_\_

Revised 08/05/2014

DPS000050

## INFORMATION REQUIRED WITH CHARGING REQUEST

IF ANY OF THE CHARGES ARE LISTED BELOW YOU **MUST** INCLUDE THE INFORMATION REQUESTED BEFORE WE CAN REVIEW THE CHARGING REQUEST. PLEASE MARK THE APPROPRIATE BOXES INDICATING THAT THE INFORMATION IS INCLUDED IN THE CHARGING REQUEST.

**CHARGE CATEGORY:** \_\_\_\_\_ **INFORMATION NEEDED:** \_\_\_\_\_

- EVERY CASE:**
- Criminal History
  - Audio/Video Tapes (**complete list on reverse side**)
  - Witness statements
  - All supplements
  - All photos (2 copies OR via CDROM OR via email)
  - 911/dispatch tapes (check if at least requested but not received at time of charging request)

**CHILD CRIMES:** If a CCA involving a parent guardian or custodian as defined in: ARS 13-3623 (Child Abuse), 13-3601 (Fel DV), 13-1404 (Sex Abuse), 13-1405 (Sex Con w/Minor), 13-1406 (Sex Assault-Min), 13-1410 (Child Molest), 13-1417 (Cont. Sex Abuse of Child), **or** any other act which may result in *serious harm, injury or death* to a child; 13-3506 (Indecent exposure to 0-14 yr old); 13-1403 (public sex indecency -minor); 13-3019 (surrept. photo.); 13-3212 (child prostitution); 13-3506 (furnishing harmful items); 13-3552 (Com. Sex Exploit); 13-3553 (Sex Exploit); 13-3556 (admit minor to pub disp); 13-3620 (duty to report abuse):

- Check box on front of **Charging Request Form**
- Joint investigation to be conducted with CPS; must be documented in DR. *If no joint investigation done, officer must document in DR why joint investigation not conducted.*
- CD and summary report of Safe Child interview
- Was law enforcement contacted by CPS? *G Yes G No; if No, did law enforcement contact CPS? G Yes G No;*
- Is officer requesting that charges be filed? *G Yes G No*
- Please check other boxes in categories Agg Assault/DV/Drug/Sex Assault, etc. where applicable

- AGGRAVATED DUI:**
- KO
  - If Suspect's license is out of state:** Certified Copy of MVD from state of residence.
  - If Agg. DUI w/minor** - List Victim(s) on page 1 and include Victim Notification Sheet(s) with date of birth of minor
  - Blood and/or UA Lab Results
  - Admin per se / Implied consent form
  - DUI Drugs: DRE report
  - Search warrant and Return / L.E. Phlebotomist's Blood Draw Report
  - 911/dispatch tapes if phone/anonymous caller/report

- DRUGS:**
- Flash test or lab results
  - Indicate in report what paraphernalia was used for
  - Approximate weight of drugs

- VIOLATION OF ORDERS OF PROTECTION or AGG HARASSMENT or DV AGG ASSAULT or AGG ASSAULT or AGG DV**
- Certified copy of Order of Protection or IAH and Affidavit of Service upon Suspect (*If VOP or AGG HARASSMENT*)
  - Certified copy of prior DV convictions (after 1/1/99) (*If DV case*)
  - Medical Records for Victim
  - Victim Notification Sheet completed

- SEX CRIMES:**
- All medical records/photos regarding offense
  - SAN/SART records
  - Safe-child records
  - All physical evidence has been forwarded to crime lab for analysis

- PROPERTY CRIMES:**
- List and value amount of all property involved
  - Restitution amount
  - List all recovered evidence

- FORGERY/CREDIT CARD:**
- Copies of all checks/credit card receipts in issue
  - Verification from bank/check/credit card holder of forgery

**Submitting Officer's Name:** (please print) \_\_\_\_\_ **Date:** \_\_\_\_\_

REVISED 10/27/09

## DESCRIBE ALL AUDIO/VIDEO/CD-ROM's SUBMITTED

**VIDEOS:**

DPS000051

- |    |     |
|----|-----|
| 1. | 8.  |
| 2. | 9.  |
| 3. | 10. |
| 4. | 11. |
| 5. | 12. |
| 6. | 13. |
| 7. | 14. |

**AUDIO CASSETTES:**

- |    |     |
|----|-----|
| 1. | 8.  |
| 2. | 9.  |
| 3. | 10. |
| 4. | 11. |
| 5. | 12. |
| 6. | 13. |
| 7. | 14. |

**CD-ROM's:**

- |    |     |
|----|-----|
| 1. | 8.  |
| 2. | 9.  |
| 3. | 10. |
| 4. | 11. |
| 5. | 12. |
| 6. | 13. |
| 7. | 14. |

Submitting Officer's Signature \_\_\_\_\_

Date \_\_\_\_\_

Acknowledging Charging attorney's signature \_\_\_\_\_

Date \_\_\_\_\_

**CRIMINAL INVESTIGATION  
DR # I20003903**

**SEDONA POLICE DEPARTMENT  
OFFICER INVOLVED SHOOTING**



**COMPILED BY:  
THE ARIZONA DEPARTMENT OF PUBLIC SAFETY  
SPECIAL INVESTIGATIONS UNIT  
DETECTIVE ANDREW REED, #7325  
2102 WEST ENCANTO BOULEVARD  
PHOENIX, ARIZONA 85009**



**ARIZONA DEPARTMENT OF PUBLIC SAFETY**  
**TABLE OF CONTENTS**

<b>DR NUMBER:</b>	<b>I20003903</b>
-------------------	------------------

- I. SYNOPSIS
- II. INVESTIGATION
- III. FINDINGS
- IV. INTERVIEWS
- V. SUPPORTIVE DOCUMENTS
- VI. PHOTOGRAPHS

Detective Name	ID No.	Location	Date	Supervisor
Andrew Reed	7325	31030100	01/22/2020	Sergeant Matthew Monaco, #6645



# ARIZONA DEPARTMENT OF PUBLIC SAFETY

## I. SYNOPSIS

<b>DR NUMBER:</b>	<b>I20003903</b>
-------------------	------------------

On Monday, January 20, 2020, at 1321 hours, Cheryle Harrell was cleaning her rental properties located at 55 New Castle Lane in Sedona, Arizona. Harrell observed a heavy-set white male, with a mohawk wearing camouflage clothing and a heavy vest, standing on the concrete wall of her property. The white male was later identified as Jonathan David Messare, date of birth, [REDACTED]. Messare was holding a large machete and a walking stick yelling unintelligible statements. Harrell described Messare’s statements and actions to appear like he was performing a “ritual”.

Harrell walked towards Messare and requested he leave her property. Messare clenched the machete with both hands and raised it above his head. Messare walked towards Harrell and continued to yell unintelligible statements. Harrell, fearing for her life, ran into her residence and locked the door. Harrell called the Sedona Police Department (SPD) 911 emergency line to report the incident.

At 1322 hours, SPD dispatch broadcasted the emergency radio traffic. SPD Sergeant Casey Pelletier, #624, Officer William “Bill” Hunt, #461, and Officer Kevin Hudspeth, #474, responded to the scene with emergency lights and siren. All three officers were equipped with an in-vehicle dash camera and body-worn microphones. The equipment was activated and recording throughout the incident.

At 1329 hours, Pelletier, Hunt, and Hudspeth arrived on-scene at the same time. Hunt parked his vehicle approximately ten yards in front of Messare. Hudspeth positioned his vehicle to the passenger side of Hunt’s vehicle. Pelletier angled his vehicle behind Hunt’s vehicle.

Hunt immediately recognized the threat Messare posed holding a large machete. Hunt unholstered his duty handgun and gave verbal commands. Pelletier also recognized the threat Messare posed holding the machete. Pelletier unholstered his duty handgun and gave additional verbal commands for Messare to drop the weapon. Hudspeth unholstered his duty weapon and remained on the passenger side of Hunt’s vehicle.

Messare refused to obey verbal commands given by the officers. Messare clenched the machete handle with both hands and raised it above his head. Messare walked towards Hunt and Pelletier. Hunt and Pelletier continued to give verbal commands to drop the weapon. Messare continued to disobey verbal commands.

Hunt and Pelletier, fearing for their lives and the lives of fellow officers, fired their duty handguns. Hunt fired his handgun twice grazing Messare with the first shot and striking Messare with the second shot. Pelletier fired his handgun twice striking Messare both times.

Messare was spun around from the impact of the shots. Messare, still standing, did not drop the machete and walked towards Hunt and Pelletier a second time. Pelletier fired two additional shots striking Messare both times. Messare dropped the machete and fell to the ground with his

Detective Name	ID No.	Location	Date	Supervisor
Andrew Reed	7325	31030100	01/22/2020	Sergeant Matthew Monaco, #6645



## **ARIZONA DEPARTMENT OF PUBLIC SAFETY**

### **I. SYNOPSIS**

**DR NUMBER:**

**I20003903**

hands underneath his torso. Hudspeth did not fire his duty handgun due to his backdrop behind Messare. Hudspeth later explained his backdrop was a concrete embankment and feared an errant shot would result in a ricochet into a nearby apartment complex.

At 1332 hours, Hunt broadcast on his portable radio, "Shots fired!" and requested medical personnel to respond.

Hunt, Pelletier, and Hudspeth devised a plan to remove the machete from Messare. Hunt approached Messare and removed the machete and two additional weapons. The two other weapons were a buck knife and a hatchet.

At 1336 hours, personnel from the Sedona Fire District (SFD) Engine 541 and Ambulance 541 arrived on-scene.

At 1340 hours, Messare was pronounced deceased by SFD Paramedic Phillip Bruglio, #549.

SPD Command Staff contacted and requested the investigation be conducted by the Arizona Department of Public Safety.

<b>Detective Name</b>	<b>ID No.</b>	<b>Location</b>	<b>Date</b>	<b>Supervisor</b>
Andrew Reed	7325	31030100	01/22/2020	Sergeant Matthew Monaco, #6645





# ARIZONA DEPARTMENT OF PUBLIC SAFETY

## II. INVESTIGATION LIST

<b>DR NUMBER:</b>	<b>I20003903</b>
-------------------	------------------

1. AZDPS SIU Detective Andrew Reed, #7325      Investigative Report
2. AZDPS SIU Detective Stephen Kadelak, #6573      Supplemental Report
3. AZDPS SIU Detective Misty Van Tassel, #7809      Supplemental Report
4. AZDPS SIU Detective Justin Fyfe, #7460      Supplemental Report
5. AZDPS SIU Detective Gilbert Linares, #7577      Supplemental Report
6. AZDPS SIU Detective John Ruble, #5627      Supplemental Report
7. AZDPS SIU Detective Kenneth Ellis, #6659      Supplemental Report
8. AZDPS VCU Detective Daniel Sortor, #6400      Supplemental Report
9. AZDPS VCU Detective David Archambeau, #7780      Supplemental Report
10. AZDPS VCU Detective Jason Proconier, #6285      Supplemental Report
11. AZDPS VCU Sergeant Jeremy Bulger, #6754      Supplemental Report

Detective Name	ID No.	Location	Date	Supervisor
Andrew Reed	7325	31030100	01/22/2020	Sergeant Matthew Monaco, #6645



**ARIZONA DEPARTMENT OF PUBLIC SAFETY**  
**INVESTIGATIVE REPORT**

<b>DR NUMBER:</b>	<b>I20003903</b>
-------------------	------------------

This report was authored by Detective Andrew Reed, #7325, of the Arizona Department of Public Safety (AZDPS), Special Investigations Unit (SIU).

**Notification:**

On Monday, January 20, 2020, at 1350 hours, AZDPS Sergeant Matthew Monaco, #6645, notified me via cell phone of an Officer-Involved Shooting (OIS) in Sedona, Arizona. Monaco stated Sedona Police Department (SPD) officers were involved in the shooting and SIU was called to investigate the incident.

Monaco advised I was the Lead Detective for the investigation and AZDPS SIU Detective Stephen Kadelak, #6573, was assigned as my co-case detective. Monaco requested we respond to 55 New Castle Lane, Sedona, Arizona.

**Response/Arrival:**

At approximately 1500 hours, I departed my residence and drove to the scene.

At 1700 hours, I arrived at the staging area. I noticed several marked and unmarked police vehicles parked in a near-by dirt lot. I was instructed by an SPD officer conducting traffic control to walk south on the residential road to the crime scene.

At 1705 hours, I walked to the crime scene and checked myself into the Incident Command System (ICS) log with SPD Volunteer Police Officer Phil Wadsack, #V96.

**Crime Scene:**

55 New Castle Lane, Sedona, Arizona is in a wooded residential neighborhood comprised of various family-style homes. 55 New Castle Lane is located on the west side of the north and south running creek, Oak Creek. Houses line the east and west banks of Oak Creek separating the neighborhoods.

The crime scene consisted of an inner and outer perimeter marked off with yellow crime scene tape. The outer perimeter was marked off at the entrance of New Castle Island and New Castle Lane. The inner perimeter was marked off at a private drive entrance to New Castle Lane and extended to the north by 55 Creek Retreats. The inner crime scene tape extended to the south to a wooden fence adjoining near-by family homes.

Three SPD fully marked patrol vehicles were parked inside the inner perimeter. The vehicles were parked on a dirt roundabout private drive near 55 New Castle Lane. I observed a silver Airstream Travel Trailer parked on the southeast corner of the dirt roundabout.

Detective Name	ID No.	Location	Date	Supervisor
Andrew Reed	7325	31030100	01/22/2020	Sergeant Matthew Monaco, #6645



**ARIZONA DEPARTMENT OF PUBLIC SAFETY  
INVESTIGATIVE REPORT**

<b>DR NUMBER:</b>	<b>I20003903</b>
-------------------	------------------

See AZDPS SIU Detective Misty Van Tassel’s, #7809, supplemental report for a further description of the crime scene.

**(Investigative Report II.3)**

**Scene Briefing:**

At 1706 hours, AZ DPS Coconino County Criminal Targeting Unit (CTU) Detective Jared Gray, #7505, commenced the briefing. Gray provided the following information relayed from SPD personnel and discovered before my arrival:

On Monday, January 20, 2020, at 1322 hours, SPD dispatch received a 911 call from a female caller to report a trespasser on the property of 55 New Castle Lane, Sedona, AZ. The female caller described a white male with a mohawk, chanting and yelling unintelligible statements, sitting on a small, concrete style embankment of the property. The male subject was reported to be holding a large machete and walking stick.

Gray explained at 1332 hours, shots were fired by SPD officers and the white male subject was down. Gray stated Sedona Fire District (SFD) personnel and Emergency Medical Services (EMS) personnel arrived on-scene. At 1340 hours, the white male subject was pronounced deceased. The white male subject was identified as Jonathan David Messare, date of birth, [REDACTED]. Gray stated Messare resided at [REDACTED] with a roommate.

Gray stated one of the SPD officers involved in the shooting took the large machete located on the ground by Messare and secured it in the back of an SPD patrol vehicle.

**Incident Assignments:**

After the scene briefing, Monaco conducted a briefing with SIU personnel and provided assignments for all involved in the investigation. Present during the briefing and/or assisting with the investigation were the following:

- Lead Case Detective: AZDPS SIU Detective Andrew Reed, #7325
- Co-Case Detective: AZDPS SIU Detective Stephen Kadelak, #6573
- Lead Crime Scene Detective: AZDPS SIU Detective Misty Van Tassel, #7809
- Co-Crime Scene Detective: AZDPS SIU Detective Justin Fyfe, #7460
- Assisting Detective (Warrants): AZDPS SIU Detective Gilbert Linares, #7577
- Assisting Detective (Interviews): AZDPS SIU Detective John Ruble, #5627

Detective Name	ID No.	Location	Date	Supervisor
Andrew Reed	7325	31030100	01/22/2020	Sergeant Matthew Monaco, #6645



**ARIZONA DEPARTMENT OF PUBLIC SAFETY  
INVESTIGATIVE REPORT**

<b>DR NUMBER:</b>	<b>I20003903</b>
-------------------	------------------

- Assisting Detective (Interviews): AZDPS SIU Detective Kenneth Ellis, #6659
- Assisting Detective/Briefing/Interviews: AZDPS CTU Detective Jared Gray, #7505
- Scene Mapping: AZDPS VCU Detective Daniel Sortor, #6400
- Scene Mapping: AZDPS Trooper P.J. McCabe, #6512
- Scene Mapping/Assisting Detective: AZDPS CTU Detective Leo Karl, #7618
- Case Supervisor: Sergeant Matthew Monaco, #6645
- Scene Supervisor: Sergeant Gunnar Hancock, #6775
- Scene Supervisor: Sergeant Jeromy McDonald, #6513
- Incident Commander: AZDPS Major Crimes District, Captain Raul Vega, #6264
- Photographer: AZDPS Photographic Specialist Deane Tonn, #7893

Monaco requested Kadelak and I meet with the three involved SPD officers and conduct round counts of their firearms and spare magazines. Monaco stated the officers were at the SPD office located at 100 Roadrunner Drive, Sedona, Arizona.

**Chronological Sequence of Events:**

Based on the involved victim interviews, audio recordings, witness interviews, supplemental reports, crime scene evidence, and other incident related documents, the narrative below describes the events which occurred before and during the incident.

*Monday, January 20, 2020:*

At 1321 hours, SPD dispatch received a 911 call from Cheryle Harrell and stated there was a person on her property (55 New Castle Lane) with a “very large machete and very scary.” Harrell requested the call taker send officers “very quickly.” Harrell described the person as a male with a mohawk carrying a large machete and a stick. Harrell stated the male was chanting and yelling. Harrell later stated she attempted to ask the male to leave and the male began to chase after her. The male Harrell was describing was later identified as Messare.

***Case Note:** The large machete was later identified as a 24-inch-long blade sword with a black cloth wrapped on the 12-inch handle. Throughout the witness and officer interviews, the sword is referenced as a machete. The “stick” or “walking stick” was later identified as an approximate five-foot-long reinforcement bar, commonly known as rebar.*

Detective Name	ID No.	Location	Date	Supervisor
Andrew Reed	7325	31030100	01/22/2020	Sergeant Matthew Monaco, #6645



**ARIZONA DEPARTMENT OF PUBLIC SAFETY  
INVESTIGATIVE REPORT**

<b>DR NUMBER:</b>	<b>I20003903</b>
-------------------	------------------

At 1322 hours, SPD dispatched the emergency radio traffic and the following SPD officers responded to 55 New Castle Lane:

- Sergeant Casey Pelletier, #624 (Call sign: S1)
- Officer William “Bill” Hunt, #461 (Call sign: 461)
- Officer Kevin Hudspeth, #474 (Call sign: 474)

Harrell stayed on the phone with the call taker and continued to describe Messare as wearing “fatigues” and was accompanied by a docile pit bull and another dog. Harrell stated Messare continued to yell as if he was doing a “ritual” while he stood on the concrete retaining wall. Harrell explained Messare had a heavy vest and wanted the responding officers to know there might be something underneath the vest. Harrell continued to say the sword bothered her.

*Case Note: “Fatigues” is a commonly used word to describe camouflage colored, casual dress clothes or battledress clothes worn by military members.*

At 1329 hours, Pelletier, Hunt, and Hudspeth arrived on-scene at the same time. Hunt was in the first patrol vehicle to arrive and parked approximately ten yards in front of Messare. Hudspeth was in the second patrol vehicle to arrive and positioned his vehicle on the passenger side of Hunt’s vehicle. Pelletier was in the third patrol vehicle to arrive and angled his vehicle behind Hunt’s vehicle.

When SPD officers arrived, Messare was sitting with his legs crossed on the concrete retaining wall. Messare was holding the machete in his left hand. The machete and the rebar walking stick were lying across his lap.

Hunt and Hudspeth exited their patrol vehicles and engaged in conversation with Messare. Hunt immediately recognized Messare had some form of weapon and gave Messare verbal commands to put the weapon down. Messare grabbed the rebar walking stick with his right hand, the machete with his left, and stood up.

Messare faced Hunt and Pelletier and walked toward them. Pelletier and Hunt gave verbal commands for Messare to “Put the sword down!”

Messare dropped the rebar walking stick and placed his right hand on the handle of the machete forming a two-handed grip. Messare raised the machete over and behind his head. Messare assertively walked towards Hunt and Pelletier.

Hunt, Pelletier, and Hudspeth continued to verbally command Messare to “Put it down!” and “Don’t come any closer!” Messare defied all verbal commands and continued to walk towards Hunt and Pelletier.

Detective Name	ID No.	Location	Date	Supervisor
Andrew Reed	7325	31030100	01/22/2020	Sergeant Matthew Monaco, #6645



**ARIZONA DEPARTMENT OF PUBLIC SAFETY  
INVESTIGATIVE REPORT**

<b>DR NUMBER:</b>	<b>I20003903</b>
-------------------	------------------

Hunt fired two shots from his duty handgun grazing Messare’s torso with the first shot and striking him in the upper body area with the second shot. Pelletier fired two shots from his duty handgun striking Messare in the upper body area. Messare was spun around from Hunt’s and Pelletier’s initial shots but did not fall to the ground. Messare spun back around and faced Hunt and Pelletier still holding the machete. Messare walked towards Hunt and Pelletier a second time and Pelletier fired two more shots striking Messare both times. Messare fell face down to the ground with his arms underneath him.

At 1332 hours, Hunt broadcasted on his portable radio, “Shots fired!” to SPD dispatch. Hunt and Pelletier continued to give Messare verbal commands to drop the weapon. Hunt broadcasted on his portable radio for medical to respond. SPD dispatched the SFD. Hunt, Hudspeth, and Pelletier devised a plan to tactically and safely approach Messare.

At 1333 hours, SFD Engine 541 (E541) and Ambulance 541 (A541), C Shift, responded to the scene. Guardian Medical Transport was also dispatched to the scene, but later canceled.

Hudspeth and Pelletier continued to hold Messare at gunpoint while Hunt approached. Hunt attempted to remove another knife from Messare’s torso/belt area but was unsuccessful due to the sheath strapped to Messare’s body. Hunt requested Hudspeth or Pelletier to grab gloves to remove the knife attached to Messare’s body and to place him into custody. Pelletier returned to his patrol vehicle and retrieved a box of black gloves. Pelletier dropped the box of gloves on the ground near Messare. Hudspeth remained by Messare with his handgun out as cover.

Pelletier provided Hunt with gloves. Hunt and Pelletier devised a plan to pull Messare’s arms out from underneath his body to place him into custody. Pelletier retrieved Messare’s right arm and Hunt retrieved Messare’s left arm and he was placed in handcuffs with his hands behind his back.

Pelletier and Hunt rolled Messare onto his back. Pelletier walked back to his patrol vehicle and made notifications to his chain of command. Hudspeth holstered his handgun, retrieved black gloves, and assisted Hunt with removing weapons from Messare. Hudspeth and Hunt removed a total of three weapons from Messare. The three weapons were the 24-inch sword (**Scene Item MVB.6**), a hatchet (**Scene Item MVB.5**), and a buck knife (**Scene Item MVB.4**).

At 1336 hours, SFD E541 and A541 arrived on-scene. SFD personnel included:

- A541 Paramedic Phillip Bruglio, #549
- A541 Paramedic Marc Howard, #523
- E541 Firefighter Jordan Baker, #304
- E541 Firefighter Millan Zorita, #412

Detective Name	ID No.	Location	Date	Supervisor
Andrew Reed	7325	31030100	01/22/2020	Sergeant Matthew Monaco, #6645



**ARIZONA DEPARTMENT OF PUBLIC SAFETY  
INVESTIGATIVE REPORT**

<b>DR NUMBER:</b>	<b>I20003903</b>
-------------------	------------------

- E541 Firefighter Sean Chartier, #214
- E541 Firefighter Jamey Kreun, #403

The associated SFD incident number is 20-0000253.  
**(Supportive Document V.5)**

Hudspeth requested a white blanket sheet from SFD personnel and wrapped the weapons in the sheet. Hudspeth placed the sheet with the weapons in the back of his patrol vehicle.

*Case Note: Hudspeth's patrol vehicle is scene item MVB (SPD patrol unit #7). Hudspeth explained he wrapped the white blanket sheet around the weapons due to blood on the weapons. He did not want the blood to transfer onto his patrol vehicle.*

At 1340 hours, Bruglio and Howard placed leads on Messare from the portable electrocardiogram (ECG) machine to check for vital signs. Bruglio pronounced Messare deceased.

Hunt located Messare's Oregon driver's license.

Hunt requested another white blanket sheet to cover Messare to block the view from other residents. A member from the SFD retrieved a sheet from their emergency vehicle and covered Messare.

Hudspeth marked the inner perimeter and spent cartridges with crime scene tape.

**Investigative Actions:**

**Monday, January 20, 2020:**

Monaco provided a copy of Messare's criminal history which included a copy of an active felony warrant from Multnomah County Sheriff's Office in Portland, Oregon.

At 1730 hours, Kadelak and I left the scene and responded to SPD. Tonn responded to the SPD office to take photographs of the collected evidence.

At 1740 hours, Kadelak, Tonn, and I arrived at the SPD office and met with SPD Lieutenant Stephanie Foley, #439. Foley advised Pelletier, Hudspeth, and Hunt were in the conference room and guided us there.

At 1750 hours, we began four-way photographs and round counts of Pelletier, Hudspeth, and Hunt. All officers were photographed as they were dressed during the incident. All three officers

Detective Name	ID No.	Location	Date	Supervisor
Andrew Reed	7325	31030100	01/22/2020	Sergeant Matthew Monaco, #6645



**ARIZONA DEPARTMENT OF PUBLIC SAFETY  
INVESTIGATIVE REPORT**

<b>DR NUMBER:</b>	<b>I20003903</b>
-------------------	------------------

removed their department-issued body-worn dash camera microphones on-scene. The microphones were placed back into their patrol vehicles.

**Four-way Photographs, Round Counts, and Collected Evidence:**

- **Sedona Police Department Sergeant Casey Pelletier, #624:**

**Duty Handgun (Scene Item AR1):**

- Glock 17, 9mm  
Serial Number: BEAG443
- Streamlight TLR1 tactical light mounted to the handgun frame.  
Serial Number: C4-4148750514

**Inserted Magazine #1 (Scene Item AR2):**

- 17 round capacity magazine.
- 12 live Federal Luger 9mm cartridges loaded in the magazine with one cartridge in the chamber for a total of 13 cartridges.
- The chambered round was photographed separately from the magazine loaded cartridges.

**Secondary Magazine #2 (Scene Item AR3):**

- 17 round capacity magazine in a secondary magazine pouch on the duty belt.
- 16 live Federal Luger 9mm cartridges loaded in the magazine.

**Secondary Magazine #3 (Scene Item AR4):**

- 17 round capacity magazine in a secondary magazine pouch on his duty belt.
- 16 live Federal Luger 9mm cartridges loaded in the magazine.

*Case Note: Pelletier stated per SPD policy, he only loads each of his magazines with a total of 16 cartridges. The magazine inserted in the handgun is loaded with 16 cartridges and one round chambered for a total of 17 cartridges in the handgun.*

Detective Name	ID No.	Location	Date	Supervisor
Andrew Reed	7325	31030100	01/22/2020	Sergeant Matthew Monaco, #6645





**ARIZONA DEPARTMENT OF PUBLIC SAFETY  
INVESTIGATIVE REPORT**

<b>DR NUMBER:</b>	<b>I20003903</b>
-------------------	------------------

Based on the round counts, Pelletier discharged his handgun four times.

- **Sedona Police Department Officer William “Bill” Hunt, #461**

**Duty Handgun (Scene Item AR5):**

- Glock 17, 9mm  
Serial Number: BEAG461
- No tactical light mounted on the handgun.

**Inserted Magazine #1 (Scene Item AR6):**

- 17 round capacity magazine.
- 14 live Federal Luger 9mm cartridges loaded into the magazine plus one cartridge in the chamber for a total of 15 cartridges.
- The chambered cartridge was photographed separately from the magazine loaded cartridges.

**Secondary Magazine #2 (Scene Item AR7):**

- 17 round capacity magazine in a secondary magazine pouch on his duty belt.
- 16 live Federal Luger 9mm cartridges loaded in the magazine.

**Secondary Magazine #3 (Scene Item AR8):**

- 17 round capacity magazine in a secondary magazine pouch on his duty belt.
- 16 live Federal Luger 9mm cartridges loaded in the magazine.

*Case Note: Hunt stated per SPD policy, he only loads each of his magazines with a total of 16 cartridges. The magazine inserted in the handgun is loaded with 16 cartridges with one round chambered for a total of 17 cartridges in the handgun.*

Based on the round count, Hunt discharged his handgun two times.

Detective Name	ID No.	Location	Date	Supervisor
Andrew Reed	7325	31030100	01/22/2020	Sergeant Matthew Monaco, #6645



**ARIZONA DEPARTMENT OF PUBLIC SAFETY  
INVESTIGATIVE REPORT**

<b>DR NUMBER:</b>	<b>I20003903</b>
-------------------	------------------

**Four-way Photographs, Round Counts and Non-Collected Evidence:**

- **Sedona Police Department Officer Kevin Hudspeth, #474:**

**Duty Handgun (Scene Item AR.A):**

- Glock 17, 9mm  
Serial Number: BEAG455
- Streamlight TLR1 tactical light mounted to the handgun frame.  
Serial Number: 1995581115

**Inserted Magazine #1 (AR.B):**

- 17 round capacity magazine inserted into the handgun.
- 16 live Federal Luger 9mm cartridges loaded into the magazine plus one cartridge in the chamber for a total of 17 cartridges.
- The chambered cartridge was photographed separately from the magazine loaded cartridges.

**Secondary Magazine #2 (AR.C):**

- 17 round capacity magazine in a secondary magazine pouch on his outer vest.
- 16 live Federal Luger 9mm cartridges loaded in the magazine.

**Secondary Magazine #3 (Scene Item AR8):**

- 17 round capacity magazine in a secondary magazine pouch on his outer vest.
- 16 live Federal Luger 9mm cartridges loaded in the magazine.

*Case Note: Hudspeth stated per SPD policy, he only loads each of his magazines with a total of 16 cartridges. The magazine inserted in the handgun is loaded with 16 cartridges and one round chambered for a total of 17 cartridges in the handgun.*

Detective Name	ID No.	Location	Date	Supervisor
Andrew Reed	7325	31030100	01/22/2020	Sergeant Matthew Monaco, #6645



**ARIZONA DEPARTMENT OF PUBLIC SAFETY**  
**INVESTIGATIVE REPORT**

<b>DR NUMBER:</b>	<b>I20003903</b>
-------------------	------------------

Based on the round count, Hudspeth did not discharge his handgun. I returned Hudspeth his department-issued handgun, magazines, and ammunition.

Pelletier, Hunt, and Hudspeth all stated they did not use any other less-lethal or deadly weapons during the incident. They all have department-issued rifles in their vehicles but were not used in the incident.

At 1936 hours, we concluded the photographs, round counts, and evidence collection. Foley issued Pelletier and Hunt each a new handgun, magazines, and ammunition. I placed the evidence in the rear lockbox of Kadelak’s department-issued patrol vehicle. Kadelak and I left the SPD office and drove to the scene.

At 2006 hours, Kadelak and I returned to the scene. Pelletier, Hunt, and Hudspeth all arrived back on-scene to conduct a scene walkthrough. I was informed by Linares, the search warrant for the scene, Messare’s vehicle (maroon Honda Ridgeline truck with Oregon license plate 367BZR), and the residence he stayed at (71B New Castle Lane) was granted. See Linares’ supplemental report for further information regarding the search warrant.

**(Investigative Report II.5)**

At 2019 hours, I met with on-call Coconino County Attorney’s Office (CCAO) Michael Tunink. I explained to Tunink we would start the scene walkthroughs with the involved officers. The first scene walkthrough was with Pelletier. Present during the walkthrough was Tunink, Pelletier, Kadelak, Fyfe, Van Tassel, and me. Pelletier stated he was the third officer on-scene and guided us to the general area he discharged his handgun. Van Tassel placed an orange cone in the general area where Pelletier was standing at the time he shot. The walkthrough concluded at 2024 hours. The scene walkthrough was audio-recorded, and a copy was later placed into AZDPS Property and Evidence (**Scene Item AR9**).

At 2030 hours, I met with Hunt and his legal representative, Tosca Henry, from The Ledbetter Law Firm, P.L.C. Present during the walkthrough was Tunink, Hunt, Henry, Kadelak, Fyfe, Van Tassel, and me. Hunt stated he was first on-scene and guided us to the general area where he discharged his handgun. Van Tassel placed a green cone in the general area where Hunt was standing at the time he shot. The walkthrough concluded at 2036 hours. The scene walkthrough was audio-recorded, and a copy was later placed into AZDPS Property and Evidence (**Scene Item AR10**).

At 2042 hours, I met with Hudspeth and his legal representative, Tosca Henry. Present during the walkthrough was Tunink, Hudspeth, Henry, Kadelak, Fyfe, Van Tassel, and me. Hudspeth was second on-scene and guided us to the general area where he was standing when the incident occurred. Van Tassel placed a yellow cone to indicate Hudspeth’s position. Hudspeth explained he did not discharge his handgun due to the backdrop behind Messare. Hudspeth noted the concrete embankment could cause any rounds discharged and missed to ricochet into near-by

Detective Name	ID No.	Location	Date	Supervisor
Andrew Reed	7325	31030100	01/22/2020	Sergeant Matthew Monaco, #6645



**ARIZONA DEPARTMENT OF PUBLIC SAFETY**  
**INVESTIGATIVE REPORT**

<b>DR NUMBER:</b>	<b>I20003903</b>
-------------------	------------------

residential structures. Hudspeth also stated he carried a backup weapon (Glock 43, 9mm) underneath the driver’s seat of his patrol vehicle. Hudspeth stated he was not wearing the backup weapon at the time of the incident. The walkthrough concluded at 2058 hours. The walkthrough was audio-recorded, and a copy was later placed into AZDPS Central Regional Crime Lab (CRCL) Property and Evidence (**Scene Item AR11**).

At 2220 hours, Coconino County Medical Examiner (CCME) Forensic Investigator Kaitie Byrne and Forensic Technician Maisie El-Ters arrived on-scene. They took digital photographs of the scene and Messare’s body.

At 2312 hours, Byrne and El-Ters collected and transported Messare’s body to the CCME Office located at 4402 East Huntington Drive in Flagstaff, Arizona. The associated CCME case number is 20-047.

At 2356 hours, I received the ICS log from Monaco.  
**(Supportive Document V.3)**

At 0002 hours, I cleared the scene. I met with Kadelak and Fyfe to assist and transfer the collected evidence (AR1-AR11) into Fyfe’s custody. Van Tassel and Fyfe placed all collected evidence into the AZDPS CRCL Property and Evidence facility. See Fyfe’s supplemental report for further information.  
**(Investigative Report II.4)**

**Tuesday, January 21, 2020:**

At 1158 hours, Gray stated he placed an envelope with a compact disk (CD) on the AZDPS Flagstaff administrative secretary’s desk. The CD contained an audio recorded witness interview from Susan Frohman. See Gray’s supplemental report for further information regarding the witness interview.  
**(Supportive Document V.13)**

Linares advised Messare’s black CAT cellular phone search warrant was granted. See Linares’ supplemental report for further information.  
**(Investigative Report II.5)**

**Wednesday, January 22, 2020:**

At 1545 hours, Sortor provided a CD containing the crime scene measurements and raw data. The CD was impounded into the AZDPS CRCL Property and Evidence facility. (**Scene Item AR12**). See Sortor’s supplemental report for further information related to the crime scene measurements and diagram.  
**(Investigative Report II.8)**

Detective Name	ID No.	Location	Date	Supervisor
Andrew Reed	7325	31030100	01/22/2020	Sergeant Matthew Monaco, #6645



**ARIZONA DEPARTMENT OF PUBLIC SAFETY  
INVESTIGATIVE REPORT**

<b>DR NUMBER:</b>	<b>I20003903</b>
-------------------	------------------

I conducted an open-source search on Messare and reviewed several articles from the Portland, Oregon area regarding Messare and his encounter with police. One of the news articles explained Messare was naked outside a middle school, wielding a knife. Messare charged the officers on scene, stabbing one of them, before being taken into custody.

I received a phone call from Charlie Koon regarding information on Messare. Koon stated he was an acquaintance of Messare and would like to provide some background information regarding Messare. I advised Koon I would interview him on another day.

**Thursday, January 23, 2020:**

Kadelak and I drove to the AZDPS Flagstaff office located at 1100 West Kaibab Lane, Flagstaff, Arizona. At 0830 hours, I took custody of the CD Gray left on the desk (**Scene Item AR13**).

At 0857 hours, Kadelak and I arrived at the CCME office. We met with SPD Detective Brandon Bergstad, #850, and CCME Forensic Pathologist Doctor Lawrence Czarnecki for the autopsy on Messare. Bergstad was present for the autopsy for training purposes. Bergstad provided me with documents containing SPD call-aided dispatch (CAD) records, 911 calls, and SFD CAD/fire run number records (**Scene Item AR14**).

**(Supportive Document V.4)**

At 0915 hours, Czarnecki began the autopsy on Messare. At 1545 hours, the autopsy was concluded.

At 1547 hours, I took custody of evidence removed from Messare transferred from Elizabeth Ross of the CCME Office. The evidence was placed in Kadelak’s patrol vehicle. Kadelak and I departed the CCME Office and arrived at the AZDPS CRCL Property and Evidence facility at 1945 hours. I placed the evidence (AR15-AR44) into hold locker #30.

**(Supportive Document V.7)**

**Monday, January 27, 2020:**

At 1030 hours, Kadelak, Van Tassel, Fyfe, Tonn, and I arrived at the AZDPS Property and Evidence vehicle bay to process the autopsy evidence items. Tonn photographed all items before packaging. All items were processed and transferred to the AZDPS Property and Evidence room (**Scene Items AR15-44**). See the AZDPS Collected Evidence Log for further information regarding evidence removed from Messare.

**Thursday, January 30, 2020:**

Kadelak and I drove to the Ledbetter Law Firm, P.L.C. located at 1003 North Main Street,

Detective Name	ID No.	Location	Date	Supervisor
Andrew Reed	7325	31030100	01/22/2020	Sergeant Matthew Monaco, #6645



**ARIZONA DEPARTMENT OF PUBLIC SAFETY  
INVESTIGATIVE REPORT**

<b>DR NUMBER:</b>	<b>I20003903</b>
-------------------	------------------

Cottonwood, Arizona to conduct interviews with Pelletier, Hunt, and Hudspeth. At 1000 hours, we met with Tosca Henry, a legal representative for Hunt and Hudspeth.

Before the interviews of Hudspeth and Hunt, Henry requested Hudspeth and Hunt individually review their dash camera video. Hudspeth and Hunt were provided the dash camera video for review.

At 1019 hours, Kadelak and I began the interview with Hudspeth. At 1139 hours, the interview concluded. The interview was audio-recorded, transferred to a CD, and sent out for transcription. See attached interview transcript for further information. **(Scene Item AR45)**  
**(Interview Transcript IV.1)**

At 1243 hours, Kadelak and I began the interview with Hunt. At 1331 hours, the interview concluded. The interview was audio-recorded, transferred to a CD, and sent out for transcription. See attached interview transcript for further information. **(Scene Item AR46)**  
**(Interview Transcript IV.2)**

Before the interview with Pelletier, I met with Chad Smith from Yen, Pilch, and Landeen Law Firm. Pelletier was represented by Smith during the interview.

At 1354 hours, Kadelak and I began the interview with Pelletier. At 1434 hours, the interview concluded. The interview was audio-recorded, transferred to a CD, and sent out for transcription. See attached interview transcript for further information. **(Scene Item AR47)**  
**(Interview Transcript IV.3)**

**Thursday, February 6, 2020:**

I received a departmental email from Kadelak containing a SPD Officer Safety Bulletin. The bulletin was created by SPD Officer Jonathan Reed, #732.

The bulletin explained prior contacts SPD officers had with Messare citing mental health concerns and states Messare is known to carry weapons and explains his prior encounters with Portland, Oregon police. See the safety bulletin for further information.  
**(Supportive Document V.10)**

*Case Note: Pelletier, Hunt, and Hudspeth had no knowledge of Messare prior to the incident, nor recognized him when they arrived on-scene.*

**Thursday, February 13, 2020:**

I sent a cellular phone download request to AZDPS Computer Forensics Unit (CFU) Sergeant John McFarland, #4493. I requested Messare’s cellular phone be forensically downloaded and I

Detective Name	ID No.	Location	Date	Supervisor
Andrew Reed	7325	31030100	01/22/2020	Sergeant Matthew Monaco, #6645



**ARIZONA DEPARTMENT OF PUBLIC SAFETY  
INVESTIGATIVE REPORT**

<b>DR NUMBER:</b>	<b>I20003903</b>
-------------------	------------------

provided a copy of the search warrant.

**Thursday, February 27, 2020:**

Kadelak and I drove to Charlie Koon’s residence in [REDACTED]. We arrived at the Koon residence and met with Charlie and his wife, Catherine. Charlie explained he met Messare through a social club for veterans of the United States Armed Forces. The club was for veterans to socialize and talk about their struggles with post-traumatic stress disorder (PTSD). Messare and Charlie began to develop an acquaintanceship through the meetings at the social club. Charlie explained Messare had a history of drug use and Messare’s family life was suffering from it. Charlie noted Messare had, what he believed to be, mental health issues and was paranoid fearing the government was out to get him or following him. Catherine explained she received Facebook messages from Messare which did not make sense and he rambled. Catherine later sent me a departmental email with the Facebook messages Messare sent her. We concluded the interview and returned to Phoenix, Arizona. The interview was audio-recorded, transferred to a CD, and impounded into the AZDPS CRCL Property and Evidence facility. **(Scene Item AR48)**

**(Supportive Document V.14)**

**Thursday, March 19, 2020:**

At 1038 hours, I received a department email from Byrne. The email contained the autopsy report completed by Czarnecki. The autopsy report included a toxicology report from Messare’s blood. The following was found:

- Positive for Amphetamines: **114 ng/mL** – Reporting Limit: **50 ng/mL**
- Positive for Methamphetamine: **1059 ng/mL** – Reporting Limit: **50 ng/mL**
- Positive for Chlorpheniramine (Antihistamine): **594 ng/mL** – Reporting Limit **50ng/mL**
- Positive for THC: **7.2 ng/mL** – Reporting Limit: **1 ng/mL**
- Positive for THC-COOH: **88.6 ng/mL** – Reporting Limit: **3 ng/mL**
- Positive for Dextromethorphan (cough medicine): **2582 ng/mL** – Reporting Limit: **10 ng/mL**

**(Supportive Document V.15)**

**Tuesday, April 7, 2020:**

I received a departmental email from AZDPS CFU Detective Jeffery Easton, #6115. Easton stated he was unable to conduct a download on Messare’s cellular phone.

**Wednesday, April 15, 2020:**

Detective Name	ID No.	Location	Date	Supervisor
Andrew Reed	7325	31030100	01/22/2020	Sergeant Matthew Monaco, #6645



**ARIZONA DEPARTMENT OF PUBLIC SAFETY**  
**INVESTIGATIVE REPORT**

<b>DR NUMBER:</b>	<b>I20003903</b>
-------------------	------------------

At 0400 hours, I received a departmental email from the AZDPS Crime Lab. AZDPS Forensic Scientist Jared Ford, #10406, completed a firearm function test on Pelletier's handgun, AR1, and Hunt's handgun, AR5. Ford noted no malfunctions were observed.

**(Supportive Document V.11)**

**Thursday, April 16, 2020:**

I received a follow-up email stating Easton was able to download images from the secure digital (SD) memory card. See Easton's supplemental report for further information regarding the download. **(Scene Item AR49)**

**(Supportive Document V.13)**

This concludes my involvement with the investigation at the time of submittal to CCAO. The CCAO will review the case file.

Detective Name	ID No.	Location	Date	Supervisor
Andrew Reed	7325	31030100	01/22/2020	Sergeant Matthew Monaco, #6645





**ARIZONA DEPARTMENT OF PUBLIC SAFETY  
SUPPLEMENTAL REPORT**

**DR NUMBER:** 120003903

This supplement was authored by Arizona Department of Public Safety (AZDPS), Special Investigations Unit (SIU), Detective Stephen Kadelak, #6573.

**Notification:**

On Monday, January 20, 2020, (AZDPS) Special Investigations Unit (SIU) Detective Stephen Kadelak, #6573, received a phone call at 1407 hours from AZDPS SIU Sergeant Matthew Monaco, #6645, regarding an officer involved shooting at 55 New Castle Lane, Sedona, Arizona within Coconino County. Monaco requested I respond to the location. I responded from my residence at 1426 hours.

**Response / Arrival**

I arrived on location at 1639 hours and walked into the outer perimeter which was marked off with yellow crime scene tape. I met with AZDPS Captain Raul Vega, #6264, at 1651 hours who advised me AZDPS SIU Detective, Andy Reed, #7325, would be the lead case detective and I would be the co-case detective.

**Crime Scene:**

A concrete, concave, bridge approximately 40-feet in length separated the outer scene perimeter from the inner scene perimeter. The bridge was in place over a small stream. I entered the inner perimeter crime scene tape at 1645 hours after walking across the bridge and signing in the crime scene log, which was being maintained by a Sedona Police Department Volunteer Officer Phil Wadsack, #96.

Several AZDPS detectives and Sedona Police Department (SPD) personnel were just inside the crime scene tape gathering and sharing information about the incident.

From my vantage point, I observed three SPD vehicles inside the inner perimeter which were parked in a fanned-out order. SPD vehicle #14 was positioned to the left rear, SPD vehicle #7 was positioned to the right rear, and SPD vehicle #15 was in the center front position. The area appeared to be open and resembled an open camping style area with a circular style driveway and some homes located in the background.

During my initial observations, I did not walk through the crime scene while in the inner perimeter crime scene tape.

**Briefing:**

At 1705 hours, I attended a briefing led by AZDPS Criminal Targeting Unit (CTU) Detective Jared Gray, #7505. (Refer to Detective Reed’s investigative report for briefing details).

Detective Name	ID No.	Location	Date	Supervisor
Stephen Kadelak	6573	31030100	01/21/2020	Sergeant Matthew Monaco, #6645



**ARIZONA DEPARTMENT OF PUBLIC SAFETY  
SUPPLEMENTAL REPORT**

**DR NUMBER:** 120003903

**Investigative Assignments:**

Monaco verified the following assignments regarding the investigation. AZDPS SIU Detective Andy Reed, #7325, was assigned as the lead detective and I was assigned to assist him with the investigation. He also said AZDPS SIU Detective Misty Van Tassel, #7809, would be the lead crime scene investigator along with evidence collection. AZDPS SIU Detective Justin Fyfe, #7460, would assist Detective Van Tassel.

Monaco advised Reed and I to respond to the SPD located at 100 Roadrunner Drive, Sedona, Arizona to conduct round counts and meet with the three SPD officers involved in the shooting. Monaco advised the last names of the officers were Pelletier, Hudspeth, and Hunt.

Monaco also advised when this assignment was completed, we were to respond back to the 55 New Castle Lane location and assist with processing the scene.

**Investigative Actions:**

Reed and I left the scene at 1730 hours and responded to the SPD, arriving at 1740 hours. AZDPS Photographic Specialist Deane Tonn, #7893, met us at the SPD to conduct evidence photographs.

We met with SPD Lieutenant Stephanie Foley, #439, who guided us to the conference room to meet the involved officers. SPD Sergeant Casey Pelletier, #624, SPD Officer Kevin Hudspeth, #474, and SPD Officer William Hunt, #461, were the involved officers introduced to us.

At 1750 hours, we began 4-way photographs and round counts of the involved officers and concluded at 1936 hours. Pelletier, Hudspeth, and Hunt all carried department-issued Glock 17, 9-millimeter handguns. All three stated they did not utilize their department-issued rifles, or any other less lethal equipment located in their vehicles or on their duty belts. (Refer to Detective Reed’s report for details of the round counts)

I secured all evidence collected by Reed in the rear lock box of my department vehicle.

I returned to the scene at 2006 hours to participate in separate walkthrough interviews with Pelletier, Hudspeth, and Hunt.

**Scene Walkthrough:**

At 2019 hours, I accompanied Reed during walkthrough interviews with the involved officers and concluded at 2058 hours. (Refer to Reed’s report for a detailed accounts)

After the walkthroughs were completed, Hunt told me he had “9-millimeter and .223 practice ammunition located in his vehicle.” Hunt said he just wanted to alert me if it was located during our walkthrough and make me aware why he had it in his patrol vehicle.

Detective Name	ID No.	Location	Date	Supervisor
Stephen Kadelak	6573	31030100	01/21/2020	Sergeant Matthew Monaco, #6645



**ARIZONA DEPARTMENT OF PUBLIC SAFETY  
SUPPLEMENTAL REPORT**

**DR NUMBER:** 120003903

**Evidence:**

At 2115 hours, I assisted Van Tassel and Fyfe with processing and packaging evidence located at the scene. I cleared the scene on Tuesday, January 21, 2020, at 0002 hours.

I met Fyfe at my patrol vehicle and transferred the evidence collected by Reed at the SPD to Fyfe's custody at 0011 hours on Tuesday, January 21, 2020.

I cleared the area at 0013 hours.

On Tuesday, January 21, 2020, I assisted Van Tassel and Fyfe with documenting, packaging, and labeling evidence from 1300 hours until 1600 hours at the Central Regional Crime Lab (CRCL) located at 2325 North 22<sup>ND</sup> Avenue, Phoenix, Arizona 85009.

Thursday, January 23, 2020

I attended the autopsy of Jonathan David Messare (DOB) [REDACTED] at the Coconino County Medical Examiner's Office located at 4402 East Huntington Drive, Flagstaff, Arizona 86004. Doctor Lawrence Czarnecki performed the autopsy which started at 0915 hours and concluded at 1545 hours. AZDPS SIU Detective Reed was present along with Sedona Police Department Detective Brandon Bergstad, #850. Evidence items collected during the autopsy were secured by Reed at 1547 hours. (See Detective Reed's investigative report for further details)

Monday, January 27, 2020

I assisted Reed, Van Tassel, and Fyfe from 1000 hours until 1430 hours at the CRCL processing, labeling, and documenting evidence obtained from the autopsy.

Thursday, January 30<sup>th</sup>, 2020

I responded with Reed to the Ledbetter Law Firm located at 1003 North Main Street, Cottonwood, Arizona to interview the officers involved in the shooting. I assisted with interviewing SPD Officers Hudspeth, Hunt, and Sergeant Pelletier.

I assisted with the interview of Officer Hudspeth starting at 1019 hours and concluding at 1139 hours. The audio recorded interview was transferred to a digital media CD and later sent out for transcription. (Refer to Reed's investigative report for further details)

I assisted with the interview of Officer Hunt starting at 1243 hours and concluding at 1331 hours. The audio recorded interview was transferred to a digital media CD and later sent out for transcription. (Refer to Reed's investigative report for further details)

Detective Name	ID No.	Location	Date	Supervisor
Stephen Kadelak	6573	31030100	01/21/2020	Sergeant Matthew Monaco, #6645



**ARIZONA DEPARTMENT OF PUBLIC SAFETY  
SUPPLEMENTAL REPORT**

**DR NUMBER:** 120003903

I assisted with the interview of Sergeant Pelletier starting at 1354 hours and concluding at 1434 hours. The audio recorded interview was transferred to a digital media CD and later sent out for transcription. (Refer to Reed’s investigative report for further details)

Thursday, February 6, 2020

During a conversation with SPD Lieutenant Stephanie Foley on the evening of the incident, she mentioned a possible officer safety bulletin produced by SPD regarding Messare. On February 6<sup>th</sup>, 2020, at 1345 hours, I received a department e-mail from Foley with the safety bulletin attached. I forwarded the bulletin to Reed. (Refer to Reed’s investigative report for further on the bulletin)

Thursday, February 27, 2020

A male named Charlie Koon who called into the SIU office on Wednesday, January 22, 2020, at 1345 hours, stated he was a friend of Messare and would like to share background information he felt pertinent to the investigation. On February 27, 2020, Detective Reed and I met with Coon and his wife, Catherine, at their home located in [REDACTED]. The interview commenced at 0903 hours and concluded at 0938. (Refer to Reed’s investigative report for detailed information)

Nothing further.

Detective S. Kadelak #6573

Detective Name	ID No.	Location	Date	Supervisor
Stephen Kadelak	6573	31030100	01/21/2020	Sergeant Matthew Monaco, #6645



**ARIZONA DEPARTMENT OF PUBLIC SAFETY  
SUPPLEMENTAL REPORT**

<b>DR NUMBER:</b>	<b>I20003903</b>
-------------------	------------------

This supplemental report was completed by Arizona Department of Public Safety (AZ DPS), Special Investigations Unit (SIU), Detective Misty Van Tassel, #7809.

**Notification**

On January 20, 2020, at 1409 hours, I received a call from DPS SIU Sergeant Matthew Monaco, #6645. Monaco requested I respond to an officer involved shooting in the city of Sedona, Arizona. Monaco advised officers with the Sedona Police Department (SPD) were involved. Monaco advised me SIU was requested to investigate the incident at 55 New Castle Lane, Sedona, Arizona.

**Arrival**

On January 20, 2020, at 1640 hours, I arrived in the area of the crime scene and parked my DPS-issued vehicle in a dirt parking lot north of the scene outside of the outer perimeter. I observed several other marked and unmarked police vehicles in the dirt parking lot. I approached the outer perimeter on foot and observed yellow police tape blocking off a large dirt lot in the area of 55 New Castle Lane, Sedona. Inside the yellow tape, I observed three SPD fully marked patrol vehicles with no emergency lights activated. At approximately 1705 hours, I entered the outer perimeter and met with DPS SIU Sergeant Gunnar Hancock, #6775, Monaco, and DPS SIU Detective Justin Fyfe, #7460. Monaco assigned me the position of Lead Crime Scene Detective and Fyfe as Co-Crime Scene Detective.

**Briefing**

At 1705 hours, I attended a briefing conducted by DPS Detective Jared Gray, #7505. During the briefing, Gray explained the circumstances of the events which led up to the officer involved shooting in the earlier daytime hours. I learned officers with the SPD were involved in an officer involved shooting with Jonathan David Messare, DOB: [REDACTED] For further details regarding the briefing, reference the investigative report authored by DPS SIU Detective Andy Reed, #7325.

**SIU Briefing**

Immediately following the briefing, I attended a SIU briefing conducted by Monaco. The following assignments were provided:

- Lead Case Detective – SIU Detective Andy Reed, #7325
- Co-Case Detective – SIU Detective Stephen Kadelak, #6573
- Lead Crime Scene Detective – SIU Detective Misty Van Tassel, #7809
- Co-Crime Scene Detective – SIU Detective Justin Fyfe, #7460
- Crime Scene Photographer- DPS Photographic Specialist Deanne Tonn, #7893

Detective Name	ID No.	Location	Date	Supervisor
Detective M. Van Tassel	7809	31030100	04/01/2020	Sergeant Matthew Monaco #6645



**ARIZONA DEPARTMENT OF PUBLIC SAFETY  
SUPPLEMENTAL REPORT**

<b>DR NUMBER:</b>	<b>I20003903</b>
-------------------	------------------

Refer to Reed’s investigative report for further details on assignments given to DPS personnel.

**Scene**

New Castle Lane is a single two-way lane which runs in a north/south direction then turns eastbound ending in a private drive which serves as a driveway to a lot known as New Castle Island. The lot consists of a dirt road utilized by the residents. The dirt road is separated by two larger island landscapes and two smaller island landscapes consisting of dirt, rock, and trees. Yellow crime scene tape was placed across the entrance of New Castle Island at New Castle Lane in a north/south direction designating an outer perimeter. The crime scene tape was attached to two trees on either side of New Castle Lane. North of the private drive and in the outer perimeter is a green two-story apartment complex with brown trim known as 55 Creek Retreats. South of the private drive, also in the outer perimeter, is a series of six single family homes. A creek running north and south was east of the scene.

The inner perimeter starts at New Castle Lane where the private drive begins. The private drive was marked off by yellow crime scene tape preventing anyone from entering within the inner perimeter. The yellow crime scene tape ran northbound to a tree located in front of 55 Creek Retreats then eastbound curving to the south including all four island landscapes and attached to a tree near the eastern cement wall. There was a wood fence separating the inner perimeter and other family homes on the south side of the scene.

East of the inner perimeter entrance were three SPD vehicles parked between the two larger island landscapes and two smaller ones (on the north side) and a wood fence (on the south side) separating New Castle lane from the six single family homes. SPD Unit 15, bearing license plate G635GT (vehicle #1), was parked inside the inner perimeter facing east ahead of SPD Unit 14 and SPD Unit 7. To the south of SPD Unit 15 was a group of trees surrounded by rock landscape and a silver Airstream Travel trailer.

SPD Unit 7 (vehicle #2), bearing license plate G661HV, was parked on the south side of SPD Unit 15 (vehicle #1) approximately a car length behind facing southeast. SPD Unit 14 (vehicle #3), bearing license plate G634GT, was parked on the north side of SPD unit 15 (vehicle #1) approximately a car length behind facing northeast. The inner perimeter included the driveway and the four island landscapes in-between 55 Creek Retreats and the six family homes.

Adjacent to SPD Unit 15 were several spent shell casings located on the driveway east of one of the larger island landscapes closest to the east. I observed the silhouette of a body laying east of the spent shell casings and covered by a white sheet. The body was face up with the head facing east as indicated by the subject’s feet facing upright and visible from the sheet. A pair of black latex gloves laid in the dirt driveway behind SPD Unit 14. A large walking stick and a pair of black sunglasses laid a few feet east of the subject’s head in the dirt. A box of black latex gloves

Detective Name	ID No.	Location	Date	Supervisor
Detective M. Van Tassel	7809	31030100	04/01/2020	Sergeant Matthew Monaco #6645



**ARIZONA DEPARTMENT OF PUBLIC SAFETY  
SUPPLEMENTAL REPORT**

<b>DR NUMBER:</b>	<b>I20003903</b>
-------------------	------------------

and loose gloves were on the driveway northwest of the subject's feet.

**Investigative Actions**

At 1715 hours, Fyfe and I entered the outer perimeter of the crime scene to conduct an initial familiarization walk through to locate any items of evidentiary value within the inner perimeter. The inner perimeter was visible from our location; however, we were unable to enter until the search warrant was granted.

At 2000 hours, SIU Detective Gilbert Linares, #7577, informed Fyfe and I of the approved search warrant, #2020-000788, signed by the Honorable Judge Gregory J. Gnepper of the Maricopa County Superior Court.

At 2019 hours, I attended a scene walk through administered by Reed. Present during the walk through was SPD Sergeant Casey Pelletier, #624, Kadelak, Fyfe, and Coconino County Attorney Michael Tunink. Pelletier advised he was third to arrive on-scene driving vehicle unit 14 parked facing northeast just north of vehicle 15. An orange colored cone was used to mark Pelletier's location during the shooting. Pelletier identified his location where the cone was placed as the north of his vehicle near the driver's side door. The walk through concluded at 2024 hours.

At 2030 hours, I attended a scene walk through conducted by Reed. Present during the walk through was SPD Officer William Hunt, #461, Kadelak, Fyfe, Coconino County Attorney Michael Tunink, and legal representative Tosca Henry. Hunt advised he was first to arrive on-scene driving vehicle unit 15, which was parked facing east between vehicles 14 and 7. A green colored cone was used to mark Hunt's location during the shooting. Hunt identified his location where the cone was placed as north of his vehicle near the driver's side door. The walk through concluded at 2036 hours.

At 2042 hours, I attended a scene walk through administered by Reed. Present during the walk through was SPD Officer Kevin Hudspeth, #474, legal representative Tosca Henry, Kadelak, and Coconino County Attorney Michael Tunink. Hudspeth advised he was second to arrive on-scene driving vehicle unit 7 parked facing southeast just south of vehicle 15. A yellow colored cone was used to mark Hudspeth's location during the shooting. Hudspeth identified his location where the cone was placed as the south side of his vehicle near the front passenger side. Hudspeth advised once the subject was down, he removed a knife and hatchet from the suspect and placed them in his patrol car wrapped in a white sheet. Hudspeth stated he placed small pieces of crime scene tape near bullet casings to mark their location. The walk through concluded at 2058 hours.

At 2106 hours, Fyfe and I conducted a line search within the inner perimeter. We started the line search west of vehicle 14 which was parked furthest west in the crime scene and farthest west from the body. I searched walking eastbound on the north side of vehicle 14 to the concrete wall.

Detective Name	ID No.	Location	Date	Supervisor
Detective M. Van Tassel	7809	31030100	04/01/2020	Sergeant Matthew Monaco #6645



**ARIZONA DEPARTMENT OF PUBLIC SAFETY  
SUPPLEMENTAL REPORT**

<b>DR NUMBER:</b>	<b>I20003903</b>
-------------------	------------------

Fyfe searched walking eastbound on the south side of vehicle number 14 to the concrete wall. I searched westbound on the south side of vehicle 14 while Fyfe walked westbound searching on the south side of vehicle 7. During the line search, multiple items of evidentiary value were located and marked for collection. Items of evidentiary value were marked with small orange cone markers. These markers were set next to the evidentiary items and did not touch the items in any way. I did not touch or adjust any of the evidence observed.

At 2120 hours, Fyfe and I began to placard evidence to be collected later (numerical placards) and documented items of evidential value not collected (alphabetical placards). Once the scene was placarded, Photographic Specialist Tonn photographed the scene again.

At 2156 hours, Fyfe and I began the collection process of evidential items placarded and located within the crime scene. Assisting us with the collection process was Kadelak, and DPS SIU Detective John Ruble, #5627. Items located of evidentiary value were collected and notated with a numeric character. Ruble and Kadelak assisted with logging, collection, and packaging of the evidence items. Prior to items being collected, they were photographed by Tonn. I retained custody of all evidential items collected. Evidence collection was concluded at 0002 hours. Items collected are as follows (**Refer to Supportive Documents Collected Evidence Log/Search Warrant Receipt**):

**Item #MV1** One pair of Black Nitrile Gloves found on the ground behind vehicle 14 at 2157 hours.

**Item #MV2** One FC 9MM Luger shell casing found north of vehicle 15 at 2158 hours.

**Item #MV3** One FC 9MM Luger shell casing found north of vehicle 15 at 2159 hours.

**Item #MV4** One FC 9MM Luger shell casing found north of vehicle 15 at 2200 hours.

**Item #MV5** One FC 9MM Luger shell casing found north of vehicle 15 at 2201 hours.

**Item #MV6** One FC 9MM Luger shell casing found north of vehicle 15 at 2202 hours.

**Item #MV7** One FC 9MM Luger shell casing found north of vehicle 15 at 2203 hours.

**Item #MV8** Four loose gloves lying next to glove box found northeast of vehicle 15 at 2204 hours.

**Item #MV9** One ECG Electro Bag found south of vehicle 12 at 2207 hours.

**Item #MV10** One pair of sunglasses (Kaenon) found southeast of vehicle 12 at 2208 hours.

Detective Name	ID No.	Location	Date	Supervisor
Detective M. Van Tassel	7809	31030100	04/01/2020	Sergeant Matthew Monaco #6645





**ARIZONA DEPARTMENT OF PUBLIC SAFETY  
SUPPLEMENTAL REPORT**

<b>DR NUMBER:</b>	<b>I20003903</b>
-------------------	------------------

**Item #MV11** One walking stick with pouch and two green balls inside pouch found east of deceased subject at 2209 hours.

**Item #MV12** A deceased male found on the ground face up with head facing east in the inner perimeter at 2312 hours.

**Item #MVA.1** One L3 Disc retrieved from vehicle 15 at 2229 hours.

**Item #MVB.1** One PNY 32GB SD Card retrieved from vehicle 7 at 2239 hours.

**Item #MVB.2** One Oregon Driver's License (A874956) located on top of the hood of vehicle 7 at 2249 hours.

**Item #MVB.3** One pair of black nitrile gloves found on the ground behind vehicle 7 at 2259 hours.

**Item #MVB.4** One red Buck Knife with wood handle (9.5-inch blade) located in the rear cargo area of vehicle 7 at 2300 hours.

**Item #MVB.5** One hatchet with case located in the rear cargo area of vehicle 7 at 2302 hours.

**Item #MVB.6** One sword located in the rear cargo area of vehicle 7 at 2304 hours.

**Item #MVB.7** One white sheet containing items MVB.4-6 located in the rear cargo area of vehicle 7 at 2306 hours.

**Item #MVA.2** One EKG Printout found in the front seat of vehicle 15 at 2322 hours.

**Item #MVC.1** One SN #CF0231739 found from vehicle 14 at 2326 hours.

**Item #MV12.1** One white blanket located on the ground covering the deceased at 2357 hours.

**Item #GL1** One black cellular phone found on the shelf in living room at 71 B Newcastle Lane, Sedona, Arizona.

During the search of the inner perimeter, multiple items were identified; however, due to the nature of those item/s, they were not collected. Therefore, items listed were documented in place as non-collected items. The non-collected items listed below were identified and photographed (**Reference Supportive Documents Non-Evidence Collected Log**):

**Item #MVA** Ford Explorer vehicle 15 bearing license plate G635GT

Detective Name	ID No.	Location	Date	Supervisor
Detective M. Van Tassel	7809	31030100	04/01/2020	Sergeant Matthew Monaco #6645



**ARIZONA DEPARTMENT OF PUBLIC SAFETY  
SUPPLEMENTAL REPORT**

<b>DR NUMBER:</b>	<b>I20003903</b>
-------------------	------------------

**Item #MVB** Ford Explorer vehicle 7 bearing license plate G661HV

**Item #MVC** Ford Explorer vehicle 14 bearing license plate G634GT

**Item #MVD** Group of blood droplets found west of deceased feet

**Item #MVE** Group of blood droplets found west of deceased feet

**Item #MVF** Pool of blood located south of the deceased

**Item #MVG** Box of gloves found by Item #MV8

**Item #MVBH** Back up weapon (Glock 43 9mm) found in vehicle 7

**Item #MVBH.1** Magazine from back up weapon

**Item #MVBH.2** Second magazine containing 6 rounds of ammunition (FC 9mm Lugers)

**Item #MVBH.3** Third magazine containing 6 rounds of ammunition (FC 9mm Lugers)

Refer to the AZ DPS photographs and measurements for a visual depiction of the evidence locations.

Items #MVBA through MVBG do not exist. When labeling items, I skipped these letters (A-G) in error. Sequence starts MVB and skips to MVBH.

Ron Lucas took vehicle 7 along with the Glock handgun listed in item MVBH to Officer Hudspeth's residence.

At 2312 hours, Coconino County Medical Examiner Forensic Investigator Katie Byrne took possession of the deceased (MV12).

At 0005 hours, the crime scene tape was removed from the inner perimeter.

At 0013 hours, I cleared the scene and drove back to Phoenix.

At 0201 hours, the evidentiary items noted above were submitted to hold lockers at the AZ DPS Central Regional Crime Laboratory (CRCL), Property & Evidence (P&E) section, located at 2323 North 22<sup>nd</sup> Avenue in Phoenix, Arizona 85009. Items MV 1-10 and MV 12.1, MVA.1, MVA.2, MVC.1, MVB.1-3, GL1, MVB.7 and MVB.4 were submitted to hold locker #31. Items MVB.6 and MVB.5 were submitted into hold locker #10.

Detective Name	ID No.	Location	Date	Supervisor
Detective M. Van Tassel	7809	31030100	04/01/2020	Sergeant Matthew Monaco #6645



**ARIZONA DEPARTMENT OF PUBLIC SAFETY  
SUPPLEMENTAL REPORT**

<b>DR NUMBER:</b>	<b>I20003903</b>
-------------------	------------------

At 0230 hours, I placed MV11 in the south drying room due to the size of the evidence. The room was secured at 0237 hours.

On January 21<sup>st</sup>, 2020 at 1403 hours, I removed all evidence from the hold lockers with the assistance of Fyfe, Kadelak, and Reed then submitted evidentiary items to the AZ DPS Central Regional Crime Laboratory (CRCL), Property & Evidence (P&E) section.

On January 27<sup>th</sup>, 2020 at 1023 hours to 1423 hours, Fyfe, Kadelak, Tonn, Reed, and I processed and photographed Items MVB.4, MVB.5 MVB.6 (sword, hatchet, knife) and MV2-7 (shell casings) at the AZ DPS CRCL Vehicle Bay.

This concluded my involvement with this case.

Detective Name	ID No.	Location	Date	Supervisor
Detective M. Van Tassel	7809	31030100	04/01/2020	Sergeant Matthew Monaco #6645



**ARIZONA DEPARTMENT OF PUBLIC SAFETY**  
**SUPPLEMENTAL REPORT**

<b>DR NUMBER:</b>	I20003903
-------------------	-----------

This report was authored by Detective Justin Fyfe, #7460, of the Arizona Department of Public Safety (DPS), Special Investigation Unit (SIU).

**Notification**

On Monday, January 20, 2020, at 1408 hours, I spoke via cellular telephone with DPS SIU Sergeant Matthew Monaco, #6645. Monaco requested I respond to an officer involved shooting which occurred in Coconino County in the city of Sedona, Arizona. The incident involved law enforcement personnel from the Sedona Police Department (SPD). Monaco said the DPS SIU was requested to investigate the incident and respond to the scene located at 55 New Castle Lane, in Sedona, Arizona.

**Response/Arrival**

At 1452 hours, I responded to the scene from Phoenix.

At 1700 hours, I arrived on-scene and observed multiple marked and unmarked DPS, and SPD patrol vehicles. The inner and outer perimeter was secured with yellow caution tape. SPD Volunteer P. Wadsack, #V96, controlled access to the scene at the outer perimeter and logged everyone who entered and exited the scene into the Incident Command System (ICS) log. Refer to DPS SIU Detective Misty Van Tassel's, #7809, scene report for further scene details.

At 1705 hours, I entered the scene.

**Scene Briefing**

At 1706 hours, I attended a scene briefing conducted by DPS Coconino County Criminal Targeting Unit (CTU) Detective Jared Gray, #7505. Refer to DPS SIU Detective Andy Reed's, #7325, general report for further details regarding the scene briefing.

**SIU Briefing**

Immediately following the scene briefing, I attended a SIU briefing conducted by Monaco. I was tasked as co-crime scene detective to assist Van Tassel who was assigned lead crime scene detective. Lead crime scene detectives are for documenting and processing the crime scene. DPS Photographic Specialist Deanne Tonn, #7893, was assigned as the scene photographer. Refer to Reed's general report for further details on assignments given to DPS personnel.

**Investigative Actions**

At 1715 hours, Van Tassel and I conducted an initial scene orientation and walk through. Van Tassel and I walked around the exterior of the inner perimeter in a first attempt to locate any possible evidence.

At 2000 hours, SIU Detective Gilbert Linares, #7577, informed me of the approved premises

Detective Name	ID No.	Location	Date	Supervisor
J. FYFE	7460	31030100	01/20/2020	Sergeant Matthew Monaco, #6645



**ARIZONA DEPARTMENT OF PUBLIC SAFETY  
SUPPLEMENTAL REPORT**

<b>DR NUMBER:</b>	I20003903
-------------------	-----------

search warrant 2020-000788 signed by Honorable Judge Gregory J. Gnepper of the Maricopa County Superior Court.

At 2019 hours, I attended a scene walk through conducted by Reed. Present during the walk through were SPD Sergeant Casey Pelletier, #624, Van Tassel, DPS SIU Detective Stephen Kadelak, #6573, and Coconino County Attorney Michael Tunink. An orange cone was placed in the scene where Pelletier was standing at the time of the incident. Pelletier was third on scene. The walk through concluded at 2024 hours.

At 2030 hours, I attended a scene walk through conducted by Reed. Present during the walk through were SPD Officer Bill Hunt, #461, legal representative Tosca Henry, Van Tassel, Kadelak, and Coconino County Attorney Michael Tunink. A green cone was placed in the scene where Hunt was standing at the time of the incident. Hunt was first on scene. The walk through concluded at 2036 hours.

At 2042 hours, I attended a scene walk through conducted by Reed. Present during the walk through were SPD Officer Kevin Hudspeth, #474, legal representative Tosca Henry, Van Tassel, Kadelak, and Coconino County Attorney Michael Tunink. A yellow cone was placed in the scene where Hudspeth was standing at the time of the incident. Hudspeth was second on scene. The walk through concluded at 2058 hours.

At 2106 hours, Van Tassel and I conducted a line search within the inner perimeter. During the line search, multiple items of evidentiary value were observed and marked for collection. Items of evidentiary value were marked with small orange cone markers. These markers are set next to the evidentiary items and do not touch the items in any way. I did not touch or adjust any of the evidence observed.

At 2120 hours, Van Tassel and I began to placard evidence to be collected later (numerical placards) and documented items of evidential value not collected (alphabetical placards). Once the scene was placarded, Photographic Specialist Tonn photographed the scene again.

At 2156 hours, Van Tassel and I began collecting scene evidence items. Assisting us was Kadelak and DPS SIU Detective John Ruble, #5627. Tonn took additional photographs as needed. Evidence collection concluded at 0002 hours. Refer to Van Tassel's report for details of evidence items collected.

At 2312 hours, Coconino County Medical Examiner Forensic Investigator Katie Byrne took possession of the deceased (MV12).

Tuesday, January 21, 2020

Detective Name	ID No.	Location	Date	Supervisor
J. FYFE	7460	31030100	01/20/2020	Sergeant Matthew Monaco, #6645



**ARIZONA DEPARTMENT OF PUBLIC SAFETY**  
**SUPPLEMENTAL REPORT**

<b>DR NUMBER:</b>	I20003903
-------------------	-----------

At 0011 hours, Kadelak relayed evidence items AR1 through AR8 to me for transport to the DPS Central Regional Crime Lab (CRCL), Property and Evidence Section (PES), located at 2323 North 22<sup>nd</sup> Avenue in Phoenix, Arizona. Refer to Reed’s general report for details of evidence items he collected.

At 0015 hours, I departed the scene for the DPS CRCL PES.

At 0211 hours, I submitted evidence items AR1 through AR8 into CRCL PES evidence hold locker #1.

At 1403 hours, I returned to the DPS CRCL PES to assist Van Tassel with evidence processing. Refer to Van Tassel’s report for details of evidence submitted.

At 1726 hours, I spoke with Erick Harrell via telephone. Harrell owned the property where the incident occurred. Harrell said I could mail out a copy of the search warrant and receipt to the following address, 2627 North 7<sup>th</sup> Street, Phoenix, Arizona.

Wednesday, January 22, 2020

At 0836 hours, I removed evidence items MVA.1 (9327), MVB.1 (9329), and MVC.1 (9332) from the DPS CRCL PES to relay the items to the DPS Computer Forensic Unit (CFU) for analysis.

At 0926 hours, evidence items MVA.1, MB.1, and MVC.1 were released to CFU Detective John Barahona, #6801, for analysis at the Arizona Counter Terrorism Information Center (ACTIC).

At 1300 hours, I placed a copy of search warrant 2020-000788 and an evidence collected receipt into an envelope made out to Erick Harrell into the outgoing mail (certified mail 9171999991703592429982).

Thursday, January 23, 2020

At 0736 hours, I received evidence items MVA.1, MVB.1 and MVC.1 from Barahona at ACTIC as his analysis was complete.

At 0813 hours, I submitted evidence items MVA.1, MVB.1 and MVC.1 into the DPS CRCL PES.

At 1009 hours, I received via department email the forensic analysis from Barahona regarding the dashcam video from evidence items MVA.1, MVB.1 and MVC.1. I downloaded the content onto a 32-gigabyte Verbatim thumb drive and submitted it into the CRCL PES as evidence item

Detective Name	ID No.	Location	Date	Supervisor
J. FYFE	7460	31030100	01/20/2020	Sergeant Matthew Monaco, #6645



**ARIZONA DEPARTMENT OF PUBLIC SAFETY**  
**SUPPLEMENTAL REPORT**

**DR NUMBER:**

I20003903

JF1.

Monday, January 27, 2020

At 1100 hours, I assisted Reed with evidence processing from the medical examiner's autopsy. The evidence was processed at the DPS CRCL PES vehicle bay. Also present was Van Tassel, Kadelak, and Photographic Specialist Tonn. Refer to Reed's general report for evidence details.

This concludes my involvement with the matter.

Detective Name	ID No.	Location	Date	Supervisor
J. FYFE	7460	31030100	01/20/2020	Sergeant Matthew Monaco, #6645



**ARIZONA DEPARTMENT OF PUBLIC SAFETY  
SUPPLEMENTAL REPORT**

<b>DR NUMBER:</b>	<b>I20003903</b>
-------------------	------------------

This supplemental report was authored by Detective Gilbert Linares, #7577, with the Arizona Department of Public Safety (DPS), Special Investigations Unit (SIU).

**Notification**

On Monday, January 20, 2020, at 1350 hours, I spoke via cellular telephone with DPS SIU Sergeant Mathew Monaco, #6645. Monaco advised me of an officer involved shooting involving the Sedona Police Department (SPD), which occurred at 55 New Castle Lane, Sedona, Arizona. Monaco said the DPS SIU was requested to investigate the incident.

**Response/Arrival**

I responded to the scene from the Phoenix area. At approximately 1628 hours, I arrived in the area of the scene and parked my DPS-issued vehicle in a large dirt parking lot outside the outer perimeter. I approached the outer perimeter on foot and observed yellow police tape blocking off a large dirt lot in the area of 55 New Castle Lane, Sedona. Inside the yellow tape, I observed three SPD fully marked patrol vehicles. At approximately 1631 hours, I entered the outer perimeter and met with DPS SIU Sergeant Gunnar Hancock, #6775. Hancock assigned me to begin a search warrant for the scene.

I returned to my vehicle and began a search warrant.

**Briefing**

At 1706 hours, I attended an incident briefing inside the outer perimeter of the scene. The briefing was provided by DPS Detective Jared Gray, #7505. During the briefing, Gray briefed the circumstances of the events which led up to the officer involved shooting. I learned officers with the SPD were involved in a deadly officer involved shooting with Jonathan David Messare DOB: [REDACTED]. Messare was currently residing at [REDACTED] and his vehicle, a maroon Honda Ridgeline pickup truck bearing Oregon license plate of 367BZR, was parked in front of 71B New Castle Lane. See DPS SIU Detective Reed's, #7325, general report for further information relating to the briefing.

**SIU Briefing**

At the conclusion of the briefing provided by Gray, I attended a SIU briefing conducted by Monaco. During this briefing, Monaco assigned Reed as the case detective and DPS SIU Detective Kadelak, #6573, as the co-case detective. I was assigned to author the search warrant for the scene, the vehicle belonging to Messare, and the residence in which Messare was at the night prior to the incident, which was identified as [REDACTED].

Detective Name	ID No.	Location	Date	Supervisor
Detective Gilbert Linares	7577	31030100	01/20/2020	Sergeant Matthew Monaco, #6645





**ARIZONA DEPARTMENT OF PUBLIC SAFETY  
SUPPLEMENTAL REPORT**

<b>DR NUMBER:</b>	<b>I20003903</b>
-------------------	------------------

**Investigative Actions**

I authored a search warrant for the dirt lot and parking area in front of 55 and 65 New Castle Lane, Sedona, Arizona, the residence of 71B New Castle Lane, Sedona, Arizona, and the maroon Honda Ridgeline pickup truck bearing Oregon license plate of 367BZR which belonged to Messare. The Honorable Judge Gregory J. Gnepper of the Maricopa County Superior Court signed and authorized search warrant #SW2020-000788 authorizing the immediate search of the above described properties and vehicle.

At approximately 2021 hours, I took entry photos of 71B New Castle Lane and of the maroon Honda Ridgeline. After conducting entry photos of the residence and vehicle, a search was conducted. While searching the residence, detectives located a black CAT cell phone located in the living room of the residence. The cell phone was identified belonging to Messare. The cell phone was collected and itemized as item GL1. The cell phone was later provided to DPS SIU Detective Fyfe, #7460, who was assigned as the co-crime scene investigator.

After searching the residence and vehicle, I took exit photographs.

Prior to searching the house and vehicle, I provided a copy of the search warrant to the owner of the residence, Peter Anthony McLoughlin, DOB: [REDACTED].

**January 21, 2020**

I authored a search warrant for the black CAT cell phone seized on January 20, 2020. The Honorable Judge James P. Buesing of the Maricopa County Superior Court signed and granted search warrant #SW2020-000836 granting the search of the black CAT cell phone belonging to Messare.

**January 22, 2020**

I returned search warrants #SW2020-000788 and #SW2020-000836 to the Maricopa County Superior Court. The black CAT cell phone belonging to Messare is pending a physical electronic download.

Both search warrants and search warrant returns were provided to Detective Reed.

This concludes my involvement with this matter.

Detective Name	ID No.	Location	Date	Supervisor
Detective Gilbert Linares	7577	31030100	01/20/2020	Sergeant Matthew Monaco, #6645



**ARIZONA DEPARTMENT OF PUBLIC SAFETY  
SUPPLEMENTAL REPORT**

<b>DR NUMBER:</b>	<b>120003903</b>
-------------------	------------------

This supplemental report was authored by Arizona Department of Public Safety (AZDPS), Special Investigations Unit (SIU), Detective John D. Ruble, #5627.

**Notification**

On Monday, January 20, 2020, at 1420 hours, AZDPS SIU Sergeant Jeromy McDonald, # 6513, contacted me via telephone and requested I respond in reference to an officer-involved shooting investigation in Sedona, Arizona. McDonald advised the officer-involved shooting involved the Sedona Police Department. I was advised the suspect sustained fatal injuries and was deceased at the scene. The location of the incident was at 55 Newcastle Lane, Sedona, Arizona.

**Response/Arrival**

At 1506 hours, I departed my residence and responded to the incident location. Upon arrival, I saw the area was cordoned off with yellow crime scene tape, which restricted access into 55 Newcastle Lane. I met with Sergeant McDonald who assigned me to interview a witness/victim, Cheryle Harrell. I was told Harrell was at her home located at 71 Cypress, Sedona. SIU Detective Kenneth Ellis, #6659, and I responded to the residence of 71 Cypress. At 1753 hours, Ellis and I conducted a recorded interview with Harrell. The interview was conducted at 71 Cypress, Sedona. Refer to interview summary.

In summary, Harrell recalled the following information:

- Harrell was cleaning one of her rental properties located at 55 Newcastle Lane when an unknown male walked onto the property.
- Harrell approached the male who was chanting, yelling, carrying a large stick and machete.
- Harrell told the male he was on private property and he would have to leave.
- Harrell said the male raised both the large stick and machete above his head and fearing for her life, she immediately returned to unit, #17, and called the 911 emergency operator.
- Harrell saw three Sedona Police Department officers arrive and order the male to drop his weapons.
- Harrell said the male carrying the machete and large stick in his hands continued walking towards the officers, failing to follow commands to drop his weapons, was shot.

Shortly after providing the information learned during the interview with Harrell to SIU Detectives G. Linares, #7577, I was requested to conduct an interview with the tenants of 71 Newcastle Lane, apartment B. I was provided with the names of the tenants, Peter and Jovan McLoughlin.

Detective Name	ID No.	Location	Date	Supervisor
John D. Ruble	5627	31030200	02/12/2020	Sergeant J. McDonald, #6513



**ARIZONA DEPARTMENT OF PUBLIC SAFETY  
SUPPLEMENTAL REPORT**

<b>DR NUMBER:</b>	<b>120003903</b>
-------------------	------------------

At 1921 hours, Ellis and I conducted an audio-recorded interview with Peter McLoughlin and his son, Jovan Harris-McLoughlin. The interview was conducted within the Yavapai County Sheriff’s Office command van located on Juniper Lane. Peter and his son, Jovan, reside at #71 Newcastle Lane, apartment B, Sedona.

In summary, Peter McLoughlin provided the following information:

- Peter said he met Johnathan Messare through his son, Jovan, approximately two weeks ago.
- Peter said he was aware Messare was evicted from his music studio, “Steady Rhythms” located on Contractors Way, Sedona.
- Peter said he learned Messare was an Iraq war veteran and it, “Seemed like he probably suffered from post-traumatic stress disorder (PTSD) from the things he’d been through.”
- Peter said he was not at his residence on the evening of Sunday, January 19, 2020 when Messare stayed over.

In summary, Jovan Harris-McLoughlin provided the following information:

- Jovan said he met Messare approximately two months ago and considered him a friend.
- Jovan said during this time, Messare shared some of his personal life including the loss of his wife and children. Messare was in the military and served in Iraq. Jovan said Messare had an altercation with the Portland, Oregon Police Department approximately one month ago.
- Jovan said Messare needed a place to stay and he invited him to his home on Sunday, January 19, 2020. Messare brought over several items from the music studio along with clothing and a cell phone.
- Jovan said on Monday, January 20, 2020, Messare became upset and depressed concerning the loss of his wife and children.
- Messare was in the front yard of the residence calling out military-type cadence, being loud, and was carrying a sword. Jovan said, “He was one of those, like, persons that, like, been in war before so it seemed, like, he was preparing to go to some kind of war.”
- Jovan said Messare’s actions with the sword and the cadence intimidated and made Jovan uncomfortable and locked the door to his residence.
- Jovan recalled Messare saying, “Oh Father Christmas is going come back, and he was going meet the lord today.”
- Jovan said he thought about what Messare said to him and made him think maybe his friend contemplated suicide by police.
- Jovan, after seeing police vehicles drive by his home, became worried something like what occurred with the Oregon Police Department might happen again.
- Jovan said he recalled hearing someone say, “Put your weapon down.” Jovan said he believed it was the police giving that command. Jovan then recalled hearing, “Four

Detective Name	ID No.	Location	Date	Supervisor
John D. Ruble	5627	31030200	02/12/2020	Sergeant J. McDonald, #6513



**ARIZONA DEPARTMENT OF PUBLIC SAFETY  
SUPPLEMENTAL REPORT**

<b>DR NUMBER:</b>	<b>120003903</b>
-------------------	------------------

blasts.”

After the interviews, I was assigned to assist SIU Detectives G. Linares, #7577, and S. Harris, #7575, with the search of residence located at 71 Newcastle Lane, apartment B, Sedona. Shortly after the entry photographs, Harris and I conducted an evidentiary search of the living room.

During the evidentiary search, a black cell phone with the letters “CAT” was found in the living room and it was taken as evidence. After the search was completed, exit photographs were completed.

Harris and I completed an evidentiary search of a Honda Ridgeline truck bearing Oregon registration of “367-BZR,” which was parked at 71 Newcastle Lane, apartment B. Located within the center console of the Honda truck was a checkbook with the name of Jonathan Messare.

At 2130 hours, I returned the house key of 71 Newcastle Lane, apartment B, to Peter McLoughlin. I also provided Peter McLoughlin with a receipt for evidentiary items removed.

At 2150 hours, I responded to the incident location and assisted SIU Detective M. Van Tassel, #7809, and SIU Detective J. Fyfe, #7460, with documenting evidentiary items obtained at the scene.

At 0002 hours, I cleared the scene and drove to my residence in Phoenix.

*Thursday, January 30, 2020*

The recorded interviews with Cheryle Harrell and Peter McLoughlin / Jovan Harris-McLoughlin were transferred onto compact discs (CD) under evidence items JDR1 and JDR2. The evidentiary items were secured into the Central Regional Crime Lab Property and Evidence located at 2323 North 22<sup>nd</sup> Avenue, Phoenix.

This concludes my involvement in the investigation to date.

Detective Name	ID No.	Location	Date	Supervisor
John D. Ruble	5627	31030200	02/12/2020	Sergeant J. McDonald, #6513



**ARIZONA DEPARTMENT OF PUBLIC SAFETY  
SUPPLEMENTAL REPORT**

<b>DR NUMBER:</b>	<b>I20003903</b>
-------------------	------------------

This supplemental report was authored by the Arizona Department of Public Safety (DPS), Special Investigations Unit (SIU), Detective Kenneth Ellis, #6659.

**Notification**

On Monday, January 20, 2020, at approximately 1401 hours, I was at the DPS SIU office when DPS SIU Sergeant Gunnar Hancock, #6775, advised me the Sedona Police Department (SPD) was requesting our assistance to conduct the criminal investigation of an Officer Involved Shooting (OIS), involving SPD. Hancock advised the address was 55 New Castle Lane, Sedona, Arizona and requested I respond to the scene.

**Response/Arrival**

At 1424 hours, I responded to the scene from Phoenix, Arizona.

At 1628 hours, I arrived in the area of the scene. I was directed to park in an open dirt lot outside of the outer perimeter. When I exited my vehicle, I walked south along New Castle Lane and approached the scene.

On the west side of the creek overflow ditch was the outer perimeter designated with yellow crime scene tape. On the east side of the ditch was another set of yellow crime scene tape designating the inner perimeter of the crime scene. Within the inner crime scene, I observed three marked SPD vehicles in a dirt parking lot for 55 New Castle Lane. A little to the northeast of the furthest north patrol vehicle, I observed a white sheet on the ground indicative a deceased body was underneath.

After signing in with the crime scene log scribe, I entered the outer perimeter and met with Hancock. Hancock asked me to conduct a record check on the license plate to obtain the information of a maroon Honda Ridgeline pickup truck parked at 71B New Castle Lane. Hancock advised the deceased suspect may have been staying at this location and the vehicle might be his. The Honda was bearing an Oregon license plate of 367BZR. The record check revealed it was a 2006 Honda Ridgeline, the vehicle had been sold and listed the previous owners. When I returned from my vehicle to the scene, Hancock advised SPD already had this information and a briefing was pending with all known information.

**Briefing**

At 1706 hours, I was present when DPS Coconino Criminal Targeting Unit (CCTU) Detective Jared Gray, #7505, provided the initial scene briefing. For the details of the briefing, refer to DPS SIU Detective Andy Reed's, #7325, investigative report.

After the briefing, I was tasked to assist DPS SIU Detective John Ruble, #5627, with an

Detective Name	ID No.	Location	Date	Supervisor
Kenneth Ellis	6659	31030600	01/23/2020	Sergeant Gunnar Hancock, #6775



**ARIZONA DEPARTMENT OF PUBLIC SAFETY  
SUPPLEMENTAL REPORT**

<b>DR NUMBER:</b>	<b>I20003903</b>
-------------------	------------------

interview with the original reporting party to SPD 9-1-1.

**Investigative Actions**

At 1753 hours, I was present and assisted Ruble with the interview of Cheryle Harrell. The interview took place at 71 Cypress Lane, Sedona, Arizona. Harrell was identified as the 9-1-1 caller. The interview concluded at 1822 hours. For the details of the interview, refer to Ruble’s supplemental report and/or the interview audio and transcript.

After the interview, Ruble and I provided DPS SIU Detective Gilbert Linares, #7577, with information from the interview to assist him in writing the search warrant.

At 1921 hours, I was present and assisted Ruble with the interview of Peter and Joven McLoughlin. The interview took place in the Yavapai County Sheriff’s Office (YCSO) Command Van parked in the dirt lot outside of the outer perimeter. The McLoughlins were identified as friends to the suspect, who was identified as Jonathan Messare, and lived at [REDACTED]. The interview concluded at 2008 hours. For the details of the interview, refer to Ruble’s supplemental report and/or the interview audio and transcript.

At 2021 hours, I assisted with the search of 71B New Castle Lane and the 2006 Honda Ridgeline via signed search warrant. For the details of the search and items of evidentiary value seized, refer to Linares’ supplemental report.

At 2222 hours, I exited the crime scene and departed back to the Phoenix, Arizona area.

This concluded my involvement in the investigation.

Detective Name	ID No.	Location	Date	Supervisor
Kenneth Ellis	6659	31030600	01/23/2020	Sergeant Gunnar Hancock, #6775



**ARIZONA DEPARTMENT OF PUBLIC SAFETY  
SUPPLEMENTAL REPORT**

<b>DR NUMBER:</b>	<b>I20003903</b>
-------------------	------------------

This supplemental report was authored by Detective D. Sortor, #6400, from the Arizona Department of Public Safety (DPS), Vehicular Crimes Unit (VCU).

**Notification:**

On Monday, January 20, 2020 at 1415 hours, I was contacted via telephone by VCU Sergeant J. Bulger, #6754, and asked to respond to an officer involved shooting involving a Sedona Police Department (SPD) officer at 55 New Castle Lane in Sedona, Arizona. I responded from the VCU office at 1429 hours.

**Arrival:**

I arrived at 1640 hours and parked in the dirt lot at the corner of Juniper and New Castle. I walked south on New Castle to the scene. There was yellow police tape across the concrete drive delineating the outer perimeter and yellow police tape surrounding the driveway area delineating the inner perimeter of the scene. There were three SPD vehicles parked in the driveway area facing northeast. There was a deceased subject covered by a blanket northeast of the SPD vehicles,

**Investigative Actions:**

I entered the inner perimeter at 1645 hours. I assisted Trooper McCabe, #6512, as a visual observer as he flew his unmanned aircraft system (UAS). I was assigned to document and measure the scene. I used the Leica GS14 GNSS system to measure the scene. I completed 146 measurements including the driveway area and evidentiary measurements. I measured a known distance using a steel measuring tape. I exited the perimeter at 2323 hours and left the scene at 2340 hours.

On January 22, 2020, I rendered a scaled diagram of the scene using the IMS Map360 program. I used the .tif file from the UAS and an image from google earth to complete the diagram. I changed the description of the measured points from shorthand to plain English. Due to an input error the description of points 2 and 15 were changed to their correct description. The description of points 18, 19, 20, 21, and 24 were changed to their evidence number.

A compact disk containing the measurement data was given to Special Investigations Unit Detectives to be placed into DPS Property and Evidence.

This concluded my involvement in this case.

Detective Name	ID No.	Location	Date	Supervisor
D. Sortor	6400	31030400	12/23/2019	S. O'Bryant #5501



**ARIZONA DEPARTMENT OF PUBLIC SAFETY**  
**SUPPLEMENTAL REPORT**

<b>DR NUMBER:</b>	<b>I20003903</b>
-------------------	------------------

This supplemental report has been prepared by Detective D. Archambeau, #7780, from the Arizona Department of Public Safety (DPS), Vehicular Crimes Unit (VCU).

**Notification:**

On Monday January 20, 2020, at approximately 1400 hours, I was contacted by VCU Sergeant J. Bulger, #6754, regarding an officer involved shooting in Sedona, Arizona. Sergeant Bulger requested I respond to the area of 55 New Castle Lane in Sedona, Arizona.

**Arrival:**

At approximately 1715 hours, I arrived at the scene. There was yellow police tape hung to delineate the scene perimeter. Inside the perimeter there was a white sheet laid over a presumably deceased person with booted feet sticking out from under one side. There were three Sedona Police Department vehicles parked nearby.

**Investigative Actions:**

I took no action and departed at approximately 1755 hours.

Detective Name	ID No.	Location	Date	Supervisor
Archambeau	7780	31030400	01/23/2020	Sergeant J. Bulger #6754





**ARIZONA DEPARTMENT OF PUBLIC SAFETY  
SUPPLEMENTAL REPORT**

<b>DR NUMBER:</b>	I20003903
-------------------	-----------

This supplemental report was authored by Detective J. L. Procunier, #6285, with the Arizona Department of Public Safety (DPS), Vehicular Crimes Unit (VCU).

**Notification**

On January 20, 2019, at 1356 hours, I was contacted by VCU Sergeant J. Bulger, #6754, to assist DPS Special Investigations Unit (SIU) with an officer involved shooting located at 55 New Castle Sedona, Arizona.

**Assignments**

I arrived and entered the scene at approximately 1725 hours.

Upon my arrival, I was advised our assistance was no longer needed. I cleared the scene and ended my involvement with this incident at approximately 1808 hours.

Detective Name	ID No.	Location	Date	Supervisor
J. L. PROCUNIER	6285	31030400	01/28/2020	J. Bulger #6754



**ARIZONA DEPARTMENT OF PUBLIC SAFETY**  
**SUPPLEMENTAL REPORT**

<b>DR NUMBER:</b>	<b>I20003903</b>
-------------------	------------------

This supplemental report has been prepared by Sergeant J. Bulger, #6754, from the Arizona Department of Public Safety (DPS), Vehicular Crimes Unit (VCU).

**Notification:**

On Monday January 20, 2020, at approximately 1407 hours, I was contacted by the Major Crimes District Commander Captain R. Vega, #6264, regarding an officer involved shooting in Sedona, Arizona. I was requested to respond to the area to assist with the measuring of the scene for the Special Investigations Unit.

**Arrival:**

When I arrived on-scene, I was informed only minimal manpower was needed for the scene and incident investigation. Captain Vega informed me that myself and three of my detectives could clear the scene.

I informed VCU Detective D. Sortor, #6400, that he would remain on scene to measure the scene and the remainder of the VCU personnel would be departing the scene.

**Investigative Actions:**

I took no action in this investigation.

Detective Name	ID No.	Location	Date	Supervisor
Sergeant J. Bulger	6754	31030400	1/24/2020	Capt. R. Vega, #6264



**ARIZONA DEPARTMENT OF PUBLIC SAFETY**

**III. FINDINGS**

<b>DR NUMBER:</b>	<b>I20003903</b>
-------------------	------------------

The investigation revealed the following concerning the actions of Jonathan Messare:

1. ARS § 13-1204A *Aggravated Assault*:

- a. Messare committed Aggravated Assault in violation of ARS § 13-1204.A2.
  - i. Messare intentionally placed Cheryle Harrell in reasonable apprehension of imminent physical injury by advancing towards Harrell while holding a sword with both hands above his head in a threatening manner advancing quickly towards Harrell.

2. ARS § 13-1204A *Aggravated Assault*:

- a. Messare committed Aggravated Assault in violation of ARS § 13-1204.A2.
  - ii. Messare intentionally placed SPD Officer William “Bill” Hunt in reasonable apprehension of imminent physical injury by advancing towards Hunt while clenching a sword with both hands above his head in a threatening manner advancing quickly towards Hunt within 20 feet.
- b. Messare committed Aggravated Assault in violation of ARS § 13-1204. A.8a.
  - i. Messare intentionally placed SPD Officer William “Bill” Hunt in reasonable apprehension of imminent physical injury by advancing towards Hunt while clenching a sword with both hands above his head in a threatening manner knowing or having reason to know the victim was a police officer.

3. ARS § 13-1204A *Aggravated Assault*:

- a. Messare committed Aggravated Assault in violation of ARS § 13-1204.A2.
  - i. Messare intentionally placed SPD Sergeant Casey Pelletier in reasonable apprehension of imminent physical injury by advancing towards Hunt and Pelletier while clenching a sword with both hands above his head in a threatening manner advancing quickly.
- b. Messare committed Aggravated Assault in violation of ARS § 13-1204. A.8a.
  - ii. Messare intentionally placed SPD Sergeant Casey Pelletier in reasonable apprehension of imminent physical injury by advancing towards Hunt and Pelletier while clenching a sword with both hands above his head in a threatening manner knowing or having reason to know the victims were police

Detective Name	ID No.	Location	Date	Supervisor
Andrew Reed	7325	31030100	01/22/2020	Sergeant Matthew Monaco, #6645



**ARIZONA DEPARTMENT OF PUBLIC SAFETY**

**III. FINDINGS**

<b>DR NUMBER:</b>	<b>I20003903</b>
-------------------	------------------

officers.

4. A.R.S. §13-1202.A1 *Threatening or intimidating*

- a. Messare committed threatening and intimidating in violation of ARS §13-1202.A1
  - i. Messare advanced towards Harrell in a threatening manner with a sword.

5. A.R.S. §13-1202.A1 *Threatening or intimidating*

- a. Messare committed threatening and intimidating in violation of ARS §13-1202.A1
  - i. Messare advanced towards Hunt in a threatening manner with a sword.

6. A.R.S. §13-1202.A1 *Threatening or intimidating*

- a. Messare committed threatening and intimidating in violation of ARS §13-1202.A1
  - i. Messare advanced towards Pelletier in a threatening manner with a sword.

The investigation revealed the following concerning the actions of SPD Officer William Hunt and SPD Sergeant Pelletier:

1. ARS §13-410C Justification: *Use of Deadly Physical Force in Law Enforcement*

- a. Hunt and Pelletier believed physical force was necessary pursuant to ARS §13-409, and,
  - i. Force was immediately necessary to effect the arrest and detention of Messare.
  - ii. Messare was given verbal commands to stop his actions by Hunt and Pelletier.
  - iii. The attempted arrest and detention were lawful.
- b. Hunt and Pelletier used Deadly Physical Force pursuant to ARS § 13-410C1.
  - i. Hunt and Pelletier used deadly physical force against Messare, after
  - ii. Messare demonstrated he had the capability of causing imminent physical injury, even death, by advancing towards Hunt and Pelletier with a sword clenched with both of his hands in a threatening manner.

Detective Name	ID No.	Location	Date	Supervisor
Andrew Reed	7325	31030100	01/22/2020	Sergeant Matthew Monaco, #6645



# **ARIZONA DEPARTMENT OF PUBLIC SAFETY**

## **III. FINDINGS**

<b>DR NUMBER:</b>	<b>I20003903</b>
-------------------	------------------

- iii. Hunt and Pelletier had reason to believe imminent use of deadly physical force was going to occur.
  
- c. Hunt and Pelletier used Deadly Physical Force pursuant to ARS § 13-410C2a.
  - i. Messare, un-solicited, advanced towards Hunt and Pelletier with a sword clenched in both hands in a threatening manner.
  - ii. Hunt and Pelletier believed their lives were in danger.
  - iii. Messare refused to comply with verbal commands from Hunt and Pelletier.

<b>Detective Name</b>	<b>ID No.</b>	<b>Location</b>	<b>Date</b>	<b>Supervisor</b>
Andrew Reed	7325	31030100	01/22/2020	Sergeant Matthew Monaco, #6645



# ARIZONA DEPARTMENT OF PUBLIC SAFETY

## IV. INTERVIEW LIST

<b>DR NUMBER:</b>	<b>I20003903</b>
-------------------	------------------

1. Interview Transcript: SPD Officer Kevin Hudspeth, #474
2. Interview Transcript: SPD Officer William "Bill" Hunt, #461
3. Interview Transcript: SPD Sergeant Casey Pelletier, #624
4. Interview Summary: Cheryle Harrell
5. Interview Transcript: Cheryle Harrell
6. Interview Summary: Susan Frohman
7. Interview Summary: Peter McLoughlin
8. Interview Transcript: Peter McLoughlin
9. Interview Summary (II.1 Report): Charlie Koon

Detective Name	ID No.	Location	Date	Supervisor
Andrew Reed	7325	31030100	01/22/2020	Sergeant Matthew Monaco, #6645

**INTERVIEW WITH KEVIN HUDSPETH**

**Q=Det. Andy Reed**

**Q1=Det. Stephen Kadelak**

**A=Ofc. Kevin Hudspeth**

**A1=Tosca Henry**

1  
2  
3  
4  
5  
6  
7  
8  
9  
10  
11  
12  
13  
14 Q: Okay. Today's date is January 30th of 2020. The current time is 1019 hours.  
15 Ah, my name is Detective (Andrew) Reed -- R-E-E-D badge number 7325  
16 Arizona Department of Public Safety Special Investigations Unit. Also with  
17 me is DPS SIU Detective.

18  
19 Q1: Stephen Kadelak badge number 6573.

20  
21 Q: Ah, this is a voluntary interview criminal, ah, voluntary criminal interview  
22 with Officer Kevin Hudspeth. If you could.

23  
24 A: Yeah. Kevin Hudspeth, ah, Kevin -- K-E-V-I-N -- Hudspeth -- H-U-D-S-P-E-  
25 T-H.

26  
27 Q: Badge number 474 with the Sedona Police Department. Ah, Officer  
28 Hudspeth's, ah, is represented by an Attorney Tosca Henry.

29  
30 A1: And that's Tosca -- T-O-S-C-A. Last name Henry -- H-E-N-R-Y.

31  
32 Q: Who is also present with us. Ah, the interview pertains to an Officer Involved  
33 Shooting that took place Monday, January 20th of 2020 at approximately  
34 1332 hours, ah, in the area of 55 Newcastle Lane in Sedona, Arizona and  
35 involves Sedona Police Officers. Ah, the interview takes place at Attorney  
36 Henry's office located at 1003 North Main Street in Cottonwood, Arizona.  
37 And the corresponding DPS, ah, department report number is I20003903. Ah,  
38 Officer Hudspeth you understand the interview is recorded and criminal in  
39 nature however is completely voluntary?

40  
41 A: Yes.

42  
43 Q: Along with that do you understand that you are free to leave at anytime and  
44 you are not compelled to answer any questions and you may discuss your  
45 question and or answer with your attorney in private as needed?

46  
47 A: Yes.  
48  
49 Q: Okay. Ah, Officer Hudspeth have you had the opportunity to review dash cam  
50 and audio footage, ah, for your, ah, from your person and your signed patrol  
51 vehicle in reference to the event that we're discussing today?  
52  
53 A: Yes. I have.  
54  
55 Q: Okay. After reviewing everything are you comfortable proceeding?  
56  
57 A: Yes. I am.  
58  
59 Q: Okay. All right. I'll start with some, ah, biographical information. Um, your  
60 full name?  
61  
62 A: Ah, Kevin Hudspeth. Oh, Kevin J. Hudspeth.  
63  
64 Q: Okay. Ah, how old were you at the time of the incident?  
65  
66 A: Ah, 52.  
67  
68 Q: Do you wear glasses or contacts?  
69  
70 A: Ah, I wear readers but just to read.  
71  
72 Q: Okay. Were they on during the incident?  
73  
74 A: No.  
75  
76 Q: Okay. Are you right-handed or left-handed?  
77  
78 A: I'm right-handed.  
79  
80 Q: And we'll get into some, ah, employment information. What is your  
81 occupation?  
82  
83 A: Ah, Police Officer.  
84  
85 Q: And with what agency?  
86  
87 A: Ah, City of Sedona.  
88  
89 Q: Okay. Do you know the address to the - your - your guys' headquarters?  
90



91 A: Yeah. 100 Road Runner Drive, Sedona, Arizona, 86336.  
92  
93 Q: Okay. Do you know the phone number?  
94  
95 A: 928-282-3100.  
96  
97 Q: And when were you - when have you been employed with the Sedona Police  
98 Department?  
99  
100 A: Um, I was hired on January 12, 2006.  
101  
102 Q: Was there any gaps in employment or breaks?  
103  
104 A: Um, from the time hired with Sedona?  
105  
106 Q: Yes.  
107  
108 A: No.  
109  
110 Q: Okay. W- ah, and your current rank is?  
111  
112 A: Ah, Police Officer.  
113  
114 Q: Patrol?  
115  
116 A: Patrol Officer.  
117  
118 Q: Okay. What's your badge number?  
119  
120 A: 474.  
121  
122 Q: And the call - your call sign during the, ah, incident?  
123  
124 ((Crosstalk))  
125  
126 A: 474.  
127  
128 Q: Okay. So your call sign is the badge number as well?  
129  
130 A: Correct.  
131  
132 Q: Okay. Ah, we'll get into your police experience. Ah, when and where did you  
133 attend the police academy?  
134  
135 A: Ah, I attended the police academy January 12, um, 2006 in Prescott Valley

136 and Prescott. Two lo- two different locations. Um, at the Northern Arizona  
137 Regional Training Academy. NARTA. Um, yeah. 2006.  
138  
139 Q: Was that a 16 - 18-week long?  
140  
141 A: Seventeen.  
142  
143 Q: Seventeen week?  
144  
145 A: Seventeen weeks.  
146  
147 Q: Ah, have you received any specialized training? Whether it be in the academy  
148 or at any point after the academy?  
149  
150 A: Specialized training as in, ah, collateral duty type of training or?  
151  
152 Q: Yeah. Any - anything, ah, SWAT experience, um, any - anything that  
153 specializes in - that would - it'd be in reference to the incident.  
154  
155 A: Ah, general instructor, um, FTO, firearms instructor, um, rifle instructor, rifle  
156 armor, um, shotgun armor, ah, quality assurance specialist for 8000 and 9000  
157 Intoxilyzer, ah, that's pretty much it.  
158  
159 Q: Okay. What is - what shift, ah, are you assigned to right now?  
160  
161 A: I'm assigned to, um, squad one. Which is day sh- day shift first half of the  
162 week. Ah, 0600 to, ah, 6:00 pm or 1800 hours.  
163  
164 Q: And how long have you been on that shift?  
165  
166 A: Ah, four-month of seg- segments. So January I was on that shift for two-  
167 months.  
168  
169 Q: So you do rotating shifts?  
170  
171 A: Rotating shifts. Correct.  
172  
173 Q: And kind of explain the rotating shifts. Are - every four-months you go from  
174 days, swings?  
175  
176 A: Um, every four-months they put out a sign-up sheet of where you wanna go  
177 next. Um, it's a - it's a seniority based, um, request for shift bids. And my last  
178 shift was nightshift and I just came to the dayshift.  
179  
180 Q: Okay. What is your regular days off?

- 181  
182 A: Ah, regular days off is every other Wednesday, Thursday, Friday, Saturday.  
183
- 184 Q: Okay. Do you work - is it 12-hour shifts?  
185
- 186 A: Yes, ah, the days we work - so and how it works is we work three days, off  
187 four days. Then the next week we'll work four days, off three days.  
188
- 189 Q: Okay. At the time of the incident where were you at in your work schedule?  
190
- 191 A: It was our long week. So, um, it was my - I worked Sunday then Monday and  
192 I - was it my long week or short week? I - I don't recall. I think it was - I think  
193 it was my long week. It might have been my short week.  
194
- 195 Q: We will get into the type - your uniform and what you were wearing at the  
196 time of the incident. Ah, could you describe in detail what you were wearing,  
197 ah, from head to toe. Try to include, ah, police patches, breast patches, any  
198 placards, anything that you had at the time of the incident.  
199
- 200 A: Yes. I was wearing - start from the feet, I guess. I was wearing, um, a pair of,  
201 um, ah, work boots. Um, course I was wearing some socks. Black socks. I was  
202 wearing, um, police, um, posse issued, ah, pants. I was wearing underwear. I  
203 was wearing a, ah, long-sleeve turtleneck type of a black sh- undershirt. Ah, I  
204 was wearing my police-issued polo. I was wearing my, ah, external vest. Um,  
205 external vest including the ballistic paneling inside. Ah, on my ballistic vest -  
206 my - my external vest I had two spare magazines on it. I had a set of handcuffs  
207 on my external vest. Ah, had my radio on my vest. Had my badge on my vest.  
208 I had my name tag on my vest. I had my American flag, um, medal American  
209 flag emblem on my vest. And I had a, ah, CVSA, or commerc- ah - ah,  
210 Commercial Vehicle Safety Administration, um, certification badge on my  
211 vest also. And of course I was wearing my duty belt. My duty belt was, ah -  
212 ah, standard posse issued, ah, duty belt. I had my - had a handcuff case on it  
213 with two handcuffs in it. Had a - I was wearing a taser that was hangin' off of  
214 my - my duty belt and was strapped to my left, ah, qu- my left quad of my leg.  
215 Um, connecting my duty belt to my body was also a pair of suspenders. Let's  
216 see. Of course I had my duty gun on my right side. Um, duty firearm, ah,  
217 Glock 17 9-millimeter. Ah, I had a magazine inside of it and it had 16-rounds  
218 in the magazine and one in the chamber. Let's see. What else? Oh, um, ah, my  
219 front right side of my duty belt was a can of, um - um, pepper spray if you  
220 will. And I'm tryin' to think if there was anything else on me. I think that was  
221 it.  
222
- 223 Q: Just to go back to your clothing. When you said, "Police polo." Ah, can you  
224 describe the color? What was attached to it? If you had shoulder patches, um,  
225 your badge. Was it a cloth badge - hard badge?

226  
227 A: So the polo shirt, um, not required to have a cloth badge on the polo shirt so  
228 there's no badge on it. The - the polo shirt itself was a dark navy blue. Ah,  
229 had, ah, the, ah, S- ah, Sedona Police Department, um, issued patches on the  
230 left and right shoulder.  
231  
232 Q: Any Police placards?  
233  
234 A: No. On the polo shirt? No.  
235  
236 Q: And how about on your vest?  
237  
238 A: On the vest, um, I do have a Police on the back of the vest. I do have a Police  
239 symbol that can fold out or fold in - tuck in. I don't recall if that was tucked in  
240 or - or pulled out.  
241  
242 Q: Okay. Ah, getting back to your - to your vest. You, ah, what color was your  
243 outer carrier?  
244  
245 A: Ah, dark navy blue. Oh, black.  
246  
247 Q: It was black?  
248  
249 A: Black.  
250  
251 Q: Y- I know you kind of described what was on there, ah, what did - was there,  
252 ah, body cam, ah, on - on person body cam that you had or anything else  
253 attached to your vest?  
254  
255 A: We don't have body cams. Ah, on my vest was a, um, a L3 in-car L3  
256 microphone. Um, also on my vest was a, um, a small mi- microphone for my  
257 radio.  
258  
259 Q: Okay. To - to describe what the microphone is or does could you walk us  
260 through that?  
261  
262 A: So the microphone is used so all I gotta do is push a button on the microphone  
263 to operate my radio to contact other Officers or Dispatch. Um, it's a - it's a  
264 microphone you use so you don't have to pull your radio - continuously pull  
265 your radio out of the pouch and hold it in the air and talk through it.  
266  
267 Q: For your microphone, ah, that's connected to your dash cam?  
268  
269 A: Ah, well I have a microphone for my radio and I have a microphone - had a  
270 microphone for the L3 dash cam.

271  
272 Q: For the dash cam.  
273  
274 A: Okay. So the microphone for the L3 dash - dash cam, um, that's used for  
275 whenever we con- contact somebody, ah, for an interview, ah, Call for Service  
276 or whatever the case. If we run code three it automatically comes on. Um, or  
277 we can manually turn it on just by flippin' a switch that's on the microphone  
278 itself.  
279  
280 Q: So you - you reference it activates when you're running code 3. Can you  
281 explain what that means?  
282  
283 A: Yeah. Code three is a - a - when we're running to an emergency call.  
284  
285 Q: And what...  
286  
287 A: With lights and sirens.  
288  
289 Q: Inside your patrol vehicle?  
290  
291 A: Yes.  
292  
293 Q: So you flip over your switch in your patrol vehicle. Turns on lights and siren.  
294 Automatically activates your dash cam that you have inside the patrol vehicle.  
295  
296 A: Correct.  
297  
298 Q: As well as the microphone.  
299  
300 A: Correct.  
301  
302 Q: Is there - would the microphone be on at any other time without it being, ah,  
303 turned on by your lights and siren?  
304  
305 A: Ah, you can manually turn it on inside the car by activating the L3 - turning  
306 the L3 system on, ah, or if you're out of your car and somebody approaches  
307 you or somethin' goes down there's a switch actually on the microphone you  
308 can flip to turn it on.  
309  
310 Q: And how do you turn it off?  
311  
312 A: To turn it off you have to go back to the patrol car and, ah, because once you  
313 hit the switch the L3 system is turned on and starts recording. So the only way  
314 to turn it off is to, ah, go to the patrol vehicle and manually turn of, ah, stop  
315 recording on the L3 system or there's a mute button on the microphone itself.

- 316  
317 Q: And where is that r- microphone or recording device located on your vest?  
318
- 319 A: Um, it's, ah, I carry it in two different positions at times and I don't recall  
320 where I had it. But, um, sometimes I carry it on my, um, the - the - my, ah,  
321 extra magazine pouch. And sometimes I carry it on a lapel on the - in the  
322 center of my outer vest.  
323
- 324 Q: Did you have it on at the time of the incident?  
325
- 326 A: Yes. I did.  
327
- 328 Q: Okay. I know you, ah, briefly got into your duty belt. Ah, can you - we're  
329 gonna go a little bit further. Can you describe your duty belt, ah, to include  
330 your holster and when you're describing it just so you can chr- kinda  
331 chronologically look at it - start with your clasp of the center of your duty belt  
332 moving clockwise around your body.  
333
- 334 A: Okay. 'Kay so, ah, the duty belt is - I don't know what the - what it's made  
335 out of. It's - it's a fake leather. Shiny fake leather material. Um, the clasp was  
336 plastic. Ah - ah, to - to lock it you just push both ends together and it clicks in  
337 and it kind of locks itself together. To, um, take it off there's a center button.  
338 You gotta push the center button and two side buttons you gotta push at the  
339 same time to unlock it. And so you can remove the belt. Um, moving - tryin'  
340 to figure out which way would be clockwise. Um, so moving clockwise, um, I  
341 guess it would be - the next think would be by my, ah, OC spray, ah, pepper  
342 spray. Whatever you wanna call it. Um, and a - a, ah, OC spray hol- holder.  
343 Ah, same material as the belt. Ah, fake leather shiny stuff. Um, after that  
344 would be my firearm in a issued holster and I don't recall what name brand  
345 the holster is. It's a holster for the, ah - ah, Glock 17 9-millimeter. Ah - ah,  
346 which attached light type of holster.  
347
- 348 Q: Can you describe the retention on that? What type of retention?  
349
- 350 A: It's a triple - triple retention.  
351
- 352 Q: Okay.  
353
- 354 A: And, um, inside the holster of course was my duty weapon - my issued duty  
355 weapon. It had the Glock 17 in it and it had a magazine in it. The magazine  
356 had 16-rounds and, um, there was one round actively in the chamber. Um,  
357 course I had, ah, my own personal, um, weapon light on it. TLR 1 on there.  
358 Ah, and it sure - was SureFire TLR 1. I can't remember what - what brand it  
359 is. Um, after that, ah, I guess you would move - keep movin' and I had a, um,  
360 I had a - I don't know what you would call it. Um, a quick disconnect radio

361 holder on my belt which I usually use when I'm doin' my commercial vehicle  
362 inspections 'cause I don't wear my outer external vest when I'm usin' that so I  
363 gotta hook my radio somewhere so I can use that. I wasn't using that at that  
364 time 'cause I was use - wearin' my external vest. Ah, I'll just keep movin'  
365 down the line. I had a, um, a baton holder on my belt. Um, use the, ah, PR  
366 Monadnock, or whatever you call it, um, type of style. Old school if you will.  
367 Um.

368  
369 Q: W- where are we at on your belt? Left or right side?

370  
371 A: Um, I'm on the left side - left side right now. Ah, right after that was g- it  
372 would be my, ah, taser holster which hangs from the belt and inside the -  
373 which is it? Ah, inside the, ah, taser holster w- was a, um, a paddle. Or I mean,  
374 excuse me. It was a paddle-type of t- taser holster. Um, and inside the taser  
375 holster was a taser. I'm not a taser guy so I have no idea what kinda taser it  
376 was. Um, movin' down the line there was a - a dual handcuff case. Um, two  
377 handcuffs in it. And then, oh, ah, four, um, four, um, keepers, ah duty belt  
378 keepers and of course like I said before the, um - um, suspenders connected to  
379 the belt.

380  
381 Q: And I believe you said it earlier you - you have two spare magazines.

382  
383 A: Two spare magazines.

384  
385 Q: For your duty weapon?

386  
387 A: For my duty weapon. Correct.

388  
389 Q: That were located on your outer carrier.

390  
391 A: Outer - outer - outer carrier.

392  
393 Q: Where at on your outer carrier?

394  
395 A: Right in the front - front. Like - like a - where your front seam of your shirt  
396 would be.

397  
398 Q: Okay. I know you touched on it earlier but let's go back to it. Ah, in particular  
399 your weapon. It is department issued or your personal?

400  
401 A: Ah, department issued.

402  
403 Q: And what's the make model?

404  
405 A: Ah, Glock 17.

406  
407 Q: And bran- or, ah, caliber?  
408  
409 A: 9-millimeter.  
410  
411 Q: Anything that you've done special to it? Ah, anything related to the trigger -  
412 the sights?  
413  
414 A: Mm, I've done - haven't done anything to the trigger or the sights.  
415  
416 Q: Okay. The only thing you did was put on your personal, ah, tactical light?  
417  
418 A: Tac- yeah. Yes.  
419  
420 Q: Okay. What time of amm- ammunition?  
421  
422 A: Ah, duty i- duty - duty issued ammunition 9-millimeter.  
423  
424 Q: Okay. When - in your magazines for your duty weapon do you know what the  
425 max capacity of ammo that you can load up into them - those magazines?  
426  
427 A: Max capacity 17-rounds.  
428  
429 Q: And how many do you guys load?  
430  
431 A: Ah, we c- we try to load one down so it's 16 per magazine.  
432  
433 Q: Is that a personal preference or is that a department?  
434  
435 A: That's a - I guess it's a department thing. A department, ah, policy.  
436  
437 Q: So every - every - every Officer in your agency loads 16-rounds in each  
438 magazine with the one - with the exception of the one in your duty weapon.  
439 But it would be a 16-round, ah, magazine or a s- 17-round magazine loaded up  
440 16-rounds with one in the chamber that's in your holster.  
441  
442 A: Correct.  
443  
444 Q: Okay. Do you have - utilize - have with you at the time any, ah, any use of  
445 force weapons, ah, beanbag, shotgun, rifle, um, rubber bullets, baton, OC,  
446 anything in addition to what you already explained on your duty belt that you  
447 keep with you or in your patrol car?  
448  
449 A: Yes. Ah, in the back of my patrol car there was a, ah, less than lethal shotgun,  
450 ah, carried, um, kinda like beanbag shots in it. And it was in a, ah, a shotgun



451 case - a cloth shotgun case that was zippered up and s- stowed in - in the back,  
452 ah, hatch of my patrol vehicle. Inside betw- inside the cab of the patrol vehicle  
453 was, um, a, ah, SIONICS AR-15 rifle. That was, ah, mounted on the w- the  
454 back compartment wall, ah, inside, you know, sittin' right by the driver's seat  
455 to the right. Um, ah, on the - on the left side of my seat, ah, next to the door I  
456 had my, ah, my PR. My - my baton if you will, um, kinda stuffed next to the  
457 seat. And under my seat was a backup weapon that I was wearin' earlier in the  
458 day.

459  
460 Q: Could you describe that?

461  
462 A: Yeah. It's a Glock 43, ah, 9-millimeter. And it's a - was in a, ah, I can't  
463 remember what you call it. Velcro-type of, um, ah, belly belt if you will. Ah,  
464 and it had two magazines inside the belly belt also.

465  
466 Q: Two magazines separate. One inside it - of...

467  
468 A: One inside. Correct.

469  
470 Q: How - what's the max capacity for those magazines?

471  
472 A: Max capacity is six.

473  
474 Q: And how many did you have loaded in there?

475  
476 A: I had, um, each extra - so I had two spare magazines and one magazine in, um,  
477 the Glock 43. Ah, each magazine has a six-round capacity. Ah, the two extra  
478 magazines had six-rounds. The magazine in my, um, firearm had five-rounds  
479 and there was one in the chamber.

480  
481 Q: Okay. Are those department issued ammunition as well?

482  
483 A: Department issued ammunition. Correct.

484  
485 Q: And is that gun your personal or department?

486  
487 A: My personal.

488  
489 Q: Okay. Detective Kadelak if you would - have anything to say?

490  
491 Q1: I just had a few follow-up questions. Um, I know we went back and forth with  
492 the color of your uniform. The vest is black and everything. What is a Sedona  
493 Department color uniform? Is it blue, black?

494  
495 A: Ah, the Sedona, ah, the pants and the polo the policy says your - your pants

496 your polo either be a Class A, B or C will be dark navy blue. Um, the e- the  
497 outer vest - exterior vest - however you wanna put it is - is right now is black.  
498  
499 Q1: Okay. So a normal Sedona Police uniform is navy blue.  
500  
501 A: Yes. Correct.  
502  
503 Q1: Okay. And, ah, just to clarify we - you, ah, we talked about the - the back-up  
504 gun and the beanbag gun and - and different things like that - that you had it in  
505 your vehicle. But you didn't utilize any of that equipment.  
506  
507 A: No.  
508  
509 Q1: At the time. Correct?  
510  
511 A: No. I didn't.  
512  
513 Q1: Okay. Thank you.  
514  
515 Q: We good with his attire?  
516  
517 Q1: Good. Thank you.  
518  
519 Q: All right. Ah, we'll move on to your patrol vehicle. Ah, can you describe the  
520 color or what the label markings are?  
521  
522 A: Yes, ah, so the patrol vehicle I believe is a, ah, 2017, ah, Ford, um, oh, my  
523 God what's it called, um, Interceptor. Um, it's bl- all black. It has logos on,  
524 ah, both the left and right side. Ah, in blue silver and white colors and some  
525 that say Police and in the letters of Police it has some, ah, very - I believe  
526 mountains on it that's supposed to depict Sedona. And on the side of the  
527 vehicle is - left and right on the side of the vehicles it also s- there's also  
528 Sedona on our police Sedona on - now I can't remember - on the side of the  
529 vehicles. These are one of the two on - on both side of the vehicles. On the  
530 back it also - there's also Police, ah, in, ah, blue and white kinda silver-ish on  
531 the back also.  
532  
533 Q: What's that vehicle number?  
534  
535 A: Ah, seven.  
536  
537 Q: Does it have - is it equipped with lights and siren?  
538  
539 A: It is equipped with lights and sirens and L3 system.  
540

541 Q: Were they fully-functioning at the time?  
542  
543 A: Fully-functioning. Yes sir.  
544  
545 Q: 'Kay. Was there anything that you noted in the police vehicle that wasn't  
546 operable?  
547  
548 A: Ah.  
549  
550 Q: That would hinder you from doing your day to day job as a Police Officer?  
551  
552 A: No sir.  
553  
554 Q: Okay. Does anybody need a break?  
555  
556 A: I'm good.  
557  
558 Q: We'll briefly talk about from the moment you got on shift and, ah, things that  
559 you, ah, things that you did prior to this incident. Ah, had you made any - you  
560 logged on at six I believe - six am.  
561  
562 A: Um, logged on approximately ten-minutes til six.  
563  
564 Q: Okay. From the time that you logged on to just prior to the incident did you  
565 conduct any traffic stops? Did you answer any radio calls for service? Um,  
566 help any stranded motorists? Did you do any of those?  
567  
568 A: I do not remember. I do remember doing a lot of paperwork at the beginning  
569 of my shift. Um, I don't remember actually doing any traffic stops I think that  
570 morning or taking any other Calls for Service. Prior to that call other than a  
571 check welfare on a possible, um, mental subject - mental health subject.  
572  
573 Q: Is that separate from the incident that we're talking about?  
574  
575 A: Yes. Correct.  
576  
577 Q: Where was that?  
578  
579 A: That was - that was off White Bear and Dry Creek. It was a - I can't remember  
580 the address that we were called to but it was in a empty field.  
581  
582 Q: Did you make contact with anybody?  
583  
584 A: No, um, by the time we got there, um, well we were called out sayin' that, ah,  
585 there's a female subject wearin' a turquoise blanket walkin' around in circles

586 talkin' to herself and they had concerns for her. So we got to the empty field  
587 and we found what might have been the blanket but we couldn't find anybody  
588 there.

589  
590 Q: Did you contact the person that called it in?

591  
592 A: No. We didn't have time.

593  
594 Q: Okay. Did you happen to stop and get coffee anywhere or get gas?

595  
596 A: Ah, between that call and the c...

597  
598 Q: At any point from the moment you logged on, ah, and then prior to the  
599 incident?

600  
601 A: Oh, ah, yeah. I had coffee, um, from - I usually make my coffee at - at home  
602 and kind of drink it while I'm drivin' to work. So I was still drinkin' that  
603 coffee when I checked on.

604  
605 Q: Detective Kadelak.

606  
607 Q1: Ah, during the course of that day from the time you checked on until now you  
608 had interactions with people in the community.

609  
610 A: Um.

611  
612 Q1: Is that correct?

613  
614 A: Um. Yeah.

615  
616 Q1: Get - either getting coffee or - or anything that...

617  
618 A: I'm pretty sure.

619  
620 Q1: Okay.

621  
622 A: It would be...

623  
624 Q1: And during that time you were recognized as a Police Officer?

625  
626 A: Yes. Correct.

627  
628 Q1: During that time. So the - the general public noticed you in a Police car and in  
629 a Police uniform and you were noticed that day as a Police Officer to the  
630 public.

631  
632 A: Yes.  
633  
634 Q1: Okay. Was there any questions from anybody that you were not a Police  
635 Officer in your uniform or?  
636  
637 A: No.  
638  
639 Q1: That somebody did not recognize you as a Police Officer.  
640  
641 A: No.  
642  
643 Q1: Okay. Thank you.  
644  
645 Q: All right. We'll - we'll get into the chronological events of why we're here.  
646 Ah, before that do - does anybody need a break? 'Kay. Ah, did you have any  
647 civilian observer, another Officer, any K9 with you during the time of the  
648 incident?  
649  
650 A: I - there was two other Officers with me.  
651  
652 Q: In your patrol vehicle?  
653  
654 A: Oh, no. Not my - I'm sorry. I was solo in my patrol vehicle.  
655  
656 Q: Okay. Ah, where were you when you learned of the incident?  
657  
658 A: I was on - I was on a call, ah, off White - White Bear and Dry Creek in  
659 Sedona.  
660  
661 Q: As a point of reference - about how far is that from the - the radio call that you  
662 received?  
663  
664 A: It was on the West side of town and, ah, the call that I would be - receive was  
665 on the East side of town and the distance was four miles - three miles.  
666 Somewhere in that - I never measured. I don't know. It was - it was lengthy  
667 though.  
668  
669 Q: Okay. When you received the call how did you receive it? Was it on a  
670 telephone, over the radio, in-car radio, a message on your computer?  
671  
672 A: Um, well we were in the middle of the field looking for, um, ah, the subject  
673 who was havin' some po- possible mental issues and, um, we were contacted  
674 over the radio first via hot tone or emergency tone. Um, and then the  
675 Dispatcher gave us an address and told us why we were being' dispatched.

676  
677 Q: When they said why you were being dispatched what information did - did  
678 they tell you over the radio?  
679  
680 A: Told us over the radio, um, a male subject with a machete, ah, trying to get  
681 into the caller's home.  
682  
683 Q: Was it from just one caller or were there multiple callers?  
684  
685 A: Ah, I only heard of one caller at the time.  
686  
687 Q: Any other description of either the subject or what the subject was doing as  
688 you were responding to the call?  
689  
690 A: As we responded to the call there was other, ah, information such as wearing,  
691 ah, camouflage colored clothing. Um, and there was somethin' about his hair  
692 and I can't remember exactly what it was.  
693  
694 Q: Okay. From the time that you actually got on scene did you - was there any -  
695 any other information you gathered and once you got on scene everything that  
696 the caller had described did you come in contact with somebody that had that  
697 description?  
698  
699 A: Yes. We ended up comin' to that, ah, makin' contact with that subject.  
700  
701 Q: Okay. Once - once you made - once you arrived on scene.  
702  
703 A: Mm-hm.  
704  
705 Q: Ah, I'll have you articulate, ah, kind of in - in detail as best as you can  
706 everything from the situation. Whether you arrived with other Officers, if  
707 there were other people you - you contacted prior to engaging in the, ah, the  
708 subject that you were initially called for. Walk us through everything from the  
709 time that you actually got on scene.  
710  
711 A: All right. So as we were pullin' on scene, um, Officer (Hunt) was in front of  
712 me in his patrol vehicle and I was directly behind him in my patrol vehicle  
713 and, ah, Sergeant (Pelletier) was directly behind me in his patrol vehicle. As  
714 we were pullin' up to the, ah, area where the caller had called I was still  
715 looking for the address. Ah, 55 Newcastle. Um, ah, and this is a big dirt, um,  
716 pathed type of roadway. And as we pulled in, uh, Sergeant (Hunt) continued  
717 goin' straight and - 'cause I was still lookin' for 55 Newcastle. I began to  
718 make a left-hand - left-hand, ah, turn if you will onto a path and, you know,  
719 between trees. And when I was gettin' ready to go down in that direction, ah,  
720 Officer (Hunt) spotted - or got - got on the radio and said, "I got him. He's

721 directly in front of my vehicle.” At which point I stopped. Tried to make my  
722 left-hand turn and I diverted and - and went right because when I looked  
723 forward all I saw was a - a - a - a - like a camper trailer. Ah, and I - I was  
724 thinking, “Oh, the camper trailer.” So I went right and aimed my vehicle at a  
725 45-degree angle at - from the direction that Officer (Hunt)’s vehicle was and  
726 so my dash cam was kinda aimin’ at that camper trailer. And, um, Sergeant  
727 (Pelletier) came in right behind me and he went left. So he was - I don’t  
728 exactly know what his - the direction of his vehicle, um, but he went left so I  
729 was right and, um, ah, Officer (Hunt)’s vehicle wa- was between us lookin’  
730 m- straight I guess. So I got outta my patrol vehicle and when I g- was gettin’  
731 out my patrol vehicle I was already hearing, ah, Officer (Hunt), um, ta-  
732 commanding - commanding the subject to drop a hatchet ‘cause he was si-  
733 and then as I walked up I saw the subject sittin’ on the side embankment of  
734 the creek. Um, and he had a, ah, a hatchet straddled across his lap. And I was  
735 hearin’ Officer (Hunt) sayin’, um, I can’t remember he was sayin’, “Get rid of  
736 the - the - the - the machete,” or, “Throw the machete aside.” That’s - you’re  
737 gonna have to watch the video. It’s a little vague. So, um, at one point all three  
738 of us were sayin’, “Get rid of the machete.” And the guy stood up and all I  
739 remember hearin’ was him growling as I could best describe it was growling  
740 like a grizzly bear. Um, and he started walking towards the direction of, ah,  
741 Officer (Hunt) and Sergeant (Pelletier). Ah, when he started walking, ah, I - I,  
742 um, uh, unholstered my firearm and came up on sight and at one point I -  
743 that’s when I said, ah, “Stop. Drop the machete.” Or just, “Drop the machete.  
744 Drop the weapon.” Somethin’ to that effect. And, um, the subject kept walkin’  
745 towards, um, Officer, ah, (Hunt) and Sergeant (Pelletier). Um, at that time I  
746 noticed a - an embankment - a concrete embankment that was in - in my line  
747 of sight between the subject or me, the subject and behind the subject and I’ll  
748 be on my target. And so I had concerns about that. The subject was still some  
749 distance away so I came down to - to a ready position. At that point I looked  
750 over - kinda looked over at, ah, Officer (Hunt) and Sergeant (Pelletier)’s  
751 direction and saw they had their weapons out. So I - I was fine bein’ at the  
752 ready at the point. The subject continued walking after continuous commands  
753 to drop the machete, “Stop and drop the machete.” Continuously, um, walked  
754 toward them and, um, and what I felt was a, ah, a threatening manner. Um,  
755 hands - hands clinched, ah, holding the machete and growling and kinda  
756 shaking his hands with the machete as though - from my training and  
757 experience was - guy wanted to fight. Um, and so when he continued walkin’  
758 I raised my - he got even closer so I came up on sights again or came up on  
759 target again. And this time, ah, the backdrop was gettin’ worse. Concrete now  
760 and my backdrop was - was concrete and, um - um, housing that was just to  
761 the North of where the subject was walking. And so I came back down to the  
762 ready again. Um, the subject then was still walking towards Sergeant  
763 (Pelletier) and Officer (Hunt) and with continuous commands to drop the fire -  
764 er, excuse me, drop the, ah, machete. Ah, so, like, when they - when the  
765 subject g- got in my opinion way too close for my comfort it was a extreme

766 threat, um, that I was noticing I made the decision I was gonna come up on  
767 sights and - and fire. Came up on sights and right before I could fire I noticed  
768 - okay now my direct line of f- sight is r- is right at the corner of - of the  
769 houses that were there. Which concerned me. Um, but the subject was way too  
770 close and I was just gettin' ready to fire when I started hearing firing coming  
771 from the direction of, ah, Sergeant (Pelletier) and Officer (Hunt). So, um, I  
772 didn't fire. Ah, subject - from my estimation - the subject was approximately  
773 15 - 20 feet away from Sergeant (Pelletier) and Officer (Hunt) at this time.  
774 After - after the shots the subject turned around and then took maybe five or  
775 six steps back into the direction that he came from and then fell to the ground.  
776 Um, after he fell to the ground continuous - he still had the machete on him.  
777 Never dropped the machete and when he was walkin' towards us we also  
778 noticed he was carrying some type of device that looked like a hatchet  
779 strapped to his chest along with another knife that was strapped - strapped to  
780 his body also. Um, so, ah, while he was down we were constantly - well the  
781 commands continued to get rid of the hatchet. At one time I remember tellin'  
782 him, "Get rid of the hatchet. We want to help you." And there was no  
783 response from the subject. So at that time we started movin' in to, ah, if you  
784 will assess the situation and try to, ah, come - devise a plan to make contact  
785 with him to remove the - the weapons from him s- so we could try to give  
786 some type of aid. About that time, ah, um, it was decided that Sergeant (Hunt)  
787 or, excuse me, Officer (Hunt) was going to approach the man as, ah, Sergeant  
788 (Pelletier) and myself, um, ah, acted as cover, excuse me, acted as - as cover  
789 as Sergeant, excuse me, Officer (Hunt) walked to the - the subject and the plan  
790 was to step on the blade of the machete that - that could be seen and then try  
791 to roll the subject over to remove the - the machete. Um, from my recollection  
792 Officer (Hunt) was not having much luck getting the machete away from him.  
793 So Of- or Sergeant (Pelletier) approached and I held cover. Ah, once, um, they  
794 both got ov- over to - to him and they worked together they were able to get  
795 the machete away. Then they began attempting to get the other weapons from  
796 him that were tied to his body. Um, ah, and at one point I remember myself  
797 asking to, you know, check for a pulse. Ah, I can't remember who checked the  
798 pulse but I think there was, ah, "We don't have anything." And while we were  
799 doin' all this I think it was Officer (Hunt) called for fire t- to respond. And  
800 when - when we were doin' this, you know, when we finally reached the body  
801 and we were, ah, gettin' all the weapons a- away from him. That's when fire  
802 arrived and then they were approaching right after, ah, we checked pulse and  
803 they were gonna, ah, do what they could to try to help the guy out. Um, but  
804 then they - I can't remember exactly what happened then because it was kinda  
805 a lot of stuff goin' on at the same time. I was tryin' to talk to Dispatch 'cause  
806 Dispatch was asking if we were code four and I was tryin' to tell them to shut  
807 up pretty much. And, ah, so it just came down to at one point it was decided or  
808 called that, ah - ah, the subject had passed and, um, we were g- now we go -  
809 we just want to disarm him, secure the weapons. So, ah - ah, bein' the  
810 supervisor Sergeant (Pelletier) was - he had to make some phone calls. So it



811 was - now it was myself and Officer (Hunt) tryin' to remove a hatchet that  
812 was tied to his body as well as a knife that was tied to his body. So I was  
813 remov- I was attempting to remove all that stuff 'cause it was tied on pretty  
814 good and while doin' that I was able to remove the knife and the hatchet and  
815 then I found his, ah, I think it was a Oregon Driver's License that was in a  
816 little coin pouch that was also tied to his belt. Um, ah, which identified the  
817 subject, um...

818

819 A1: Do you want him to keep going with the narrative or do you have additional  
820 question and answer?

821

822 Q: W...

823

824 Q1: If - if you wanna take a br- take a break there we'll - we'll get back to that. If  
825 you wanna take a break we'll answer some questions up to that point then we  
826 can go back to disarming. Is - is - when you were disarming. Is that okay?  
827

828 A: Yeah. That's fine. I don't care.

829

830 Q1: Okay. Or what - do you feel comfortable just continuing what you're doin'?

831

832 A: Oh, I'm - I feel fine doin' what I'm doin' but I just don't know if, um, I mean,  
833 I feel - I feel fine just keep goin' if that's okay?

834

835 Q: Yeah. Ah, finish, ah, finish up. What we're gonna do, ah, we'll go back so you  
836 give your narrative. We're gonna go back. There's probably gonna be a few  
837 questions that we're going to revisit some of the things just to get clarifying  
838 questions. But you can c- ah, finish your thought and then we'll go back to  
839 that. Sound good?  
840

841 A: Mm-hm.

842

843 Q: Okay.

844

845 A: So we were able to unarm the g- the - the subject. Um, we kinda threw the, ah,  
846 the machete, the knife and the hatchet to the side. Um, at that point, ah, fire  
847 already had said he's deceased. Ah, so my next thing was okay I'm gonna seal  
848 off the area. Um, I returned to my vehicle, grabbed some police tape and I  
849 started puttin' police tape around the whole - whole scene so nobody could -  
850 could see that it was a crime scene at this point and - and not enter into the  
851 crime scene. Um, while sealin' off the area, um, well prior to sealin' off the  
852 area I - I actually put, ah, that subject's driver's license on the hood of my car,  
853 ah, 'cause I didn't wanna lose it in all the stuff I was gonna - gettin' ready to  
854 do. So I put it on the hood of my car, got into the back of my patrol car, got  
855 my p- police tape, sealed off the area. Um, noticed while I was walkin' around

856 sealin' off the area I noticed, ah, spent casings on the ground and I noticed  
857 somebody had actually stepped on one. So I attempted to put some tape  
858 around each round that I - or spent casing that I saw, ah, so nobody else would  
859 step on 'em. Um, and so I did that. And then I walked, ah, over to the weapons  
860 that were thrown away from the subject's body and, um, ah, past training  
861 experience was always on a crime scene or anywhere else - secure the  
862 weapons. Ah, a felony stop - secure the weapons. A, ah, always secure the  
863 weapons so nobody else could have access to 'em. So that's exactly what I  
864 did. I, ah, gathered the machete, knife and the hatchet and I took 'em to my  
865 car but they - they were bloody and I didn't want blood in the back of my car  
866 so I asked the fire crew if they had a extra blanket I could wrap it up with. So  
867 they said, "Sure." They brought me a blanket. I wrapped up the, ah, three  
868 items, um, and then I placed 'em in the back of my patrol car, um, because m-  
869 back of my patrol car is self-locking so once it's locked the only way to get to  
870 it is pushin' a button on my key. My - my - my, ah, key fob for my vehicle or  
871 a switch that's inside my vehicle. Um, so at that point those were secure. And,  
872 um, my next thing from past experience and training that I always knew was if  
873 there was witnesses get statements from 'em. And I don't know if I was just  
874 tryin' to keep myself busy 'cause I knew from, you know, goin' to classes is,  
875 ah, officer involved shooting classes that DPS was gonna be called to do an  
876 investigation and I don't know if I was just tryin' to keep myself busy or what  
877 the deal was but I went to what ended up bein' two callers, um, two female  
878 callers. I gave them, ah - ah, witness statement forms and I said, "If you could  
879 - if you can fill the witness statement forms out. Write down anything that, ah,  
880 that you remember from beginning of the incident when the, you know, to - to  
881 whenever fire showed up, um, and somebody will collect it from you later."  
882 Um, and from that point it was kind of, um, just hang around, um, for, like,  
883 Detectives and, ah, command staff to show up. So it was kinda like just  
884 hangin' out at that point.

885  
886 Q: Okay. I'm gonna go back, ah, all the way to the initial call.

887  
888 A: Okay.

889  
890 Q: When you first got the initial call. It was called in as a trespasser. Or what was  
891 the initial call?

892  
893 A: Initial call was, ah, male subject, um, with a machete trying to get into a  
894 woman's house.

895  
896 Q: The way you perceive it as an Officer - did you feel that - that was a fairly  
897 urgent call?

898  
899 A: I felt it was a - a - an active threat.

900

- 901 Q: Okay. Because you felt it was an active threat did you activate your lights and  
902 siren and expedite your travel to get to the scene?  
903
- 904 A: Yes. I did.  
905
- 906 Q: Okay. When you activated your lights and siren that activated the dash cam?  
907 That activated your microphone that's on your body?  
908
- 909 A: Um, in this case no. In this case my - my dash cam was already on because I  
910 was on a call. Um, so when I got into my car and I emer- activated my  
911 emergency lights my cam - my dash cam was already on. Um, so it didn't turn  
912 my c- so no. It didn't turn my camera on or my - my recording on because it  
913 was already on.  
914
- 915 Q: Okay. So it was already activated?  
916
- 917 A: It was already activated. Correct.  
918
- 919 Q: Okay. When you got on scene and you initially observed, ah - ah, the subject  
920 that matched the description from the call did you immediately recognize  
921 him? Had you known him from prior contacts?  
922
- 923 A: I've never had any contact with him before.  
924
- 925 Q: Okay.  
926
- 927 A: So I didn't recognize him.  
928
- 929 Q: Did - when you were making contact did anybody - any of the other Officers  
930 that were on scene - did anybody recognize them or say anything an audible  
931 statement of either saying the guy's name or understanding or recognizing that  
932 they've had prior contact with him?  
933
- 934 A: Um.  
935
- 936 Q: Just anything audible that they have said.  
937
- 938 A: Only - only thing audible that I know of when we were arrivin' on scene  
939 Officer (Hunt) said, "There's the guy right in front of me."  
940
- 941 Q: Okay. So you described it as a - as a dirt lot.  
942
- 943 A: It's a dirt - dirt lot with a bunch of driveway w- ah, dirt driveway paths.  
944
- 945 Q: Okay. Describe the lighting, weather conditions.

- 946  
947 A: Ah, it was daytime. Um, I mean clearly daytime. I - there was no, like,  
948 shading oth- other than tree shading. Um, the weather was good, clear from  
949 what I can recall. Um, it was a typical afternoon - early afternoon.  
950  
951 Q: Okay. In the area w- when you got outta the car was there any - was there any  
952 sounds - was there any noises that were let's just say overbearing or  
953 something that was extremely loud? Maybe from traffic, pedestrians, other  
954 people talking, dogs barking, the creek behind was loud.  
955  
956 A: Ah, nothin' that - that drew my attention away from what was goin' on. No.  
957 Um, this was a s- kind of a secluded area. So there wa- the sound of traffic  
958 wasn't there. Ah, there's no - no, like, people hangin' out yellin' or screamin'.  
959 Um, this was a s- a very secluded area.  
960  
961 Q: Okay. Detective Kadelak do you have anything?  
962  
963 Q1: Not right now.  
964  
965 Q: Okay. So I know you walk through the, ah, the actual incident where the shots  
966 were fired. So I'm - there's gonna be some things that I - I know you probably  
967 have already referenced. Ah, I might ask ya again, ah, because I didn't catch it  
968 the first time. Um, so you get on scene. You were told from the radio that  
969 there was a male subject that had a machete.  
970  
971 A: Correct.  
972  
973 Q: And he was chasing that caller around with the machete. So when you arrived  
974 on scene what - you saw him sitting down, standing up, in a car, where -  
975 where was he at?  
976  
977 A: When I got out of my - my vehicle, um, he was sitting on the side bank of the  
978 - of the Oak Creek, excuse me, um, ah, directly in front of Officer (Hunt)'s  
979 vehicle. Ah, he was sitting down. Ah, and he had the machete, ah, straddling  
980 his lap.  
981  
982 Q: Did you notice that he had anything else with him or by him?  
983  
984 A: Um, I didn't notice anything else with him or by him. Ah, my vi- my vision  
985 was directed right at him and the machete.  
986  
987 Q: Okay. As you - as you exited the vehicle did you hear anything that he started  
988 saying and or other Officers said?  
989  
990 A: Only think I remember hearing was when I got outta my - my vehicle and

- 991 started approaching was, ah, Officer (Hunt), ah, commanding him to throw the  
992 w- throw the machete a- away from him. And just hearin' the guy start to  
993 growl. That's all I remember hearing.  
994
- 995 Q: If you can gauge a distance between yourself and where you're at outside of  
996 your vehicle to the suspect or to the subject that you guys received the call on  
997 - how far away would you estimate?  
998
- 999 A: Oh, I'd estimate, um, 40 to 50 feet maybe.  
1000
- 1001 Q: And approximately how far was Officer (Hunt) from the subject?  
1002
- 1003 A: He was probably maybe, um 35 - 45 feet in distance. Oh, no - no. He was a  
1004 little bit further away. Um, ah so 45 - 55 feet. 'Cause he was approximately  
1005 about I th- I think he was probably about five-feet further away than I was.  
1006
- 1007 Q: Okay. Detective Kadelak.  
1008
- 1009 Q1: Ah, I just have a few follow-up questions. Originally when you pulled in you  
1010 said you were gonna go to the left and then you went to the right and you did  
1011 mention the - the camper that was on the side. Did you have - when you -  
1012 when you canted your vehicle to the right and on your - your dash cam was  
1013 this camper did you think that, ah, in that instance maybe the person had lived  
1014 there or - or that you brought that into view for a reason?  
1015
- 1016 A: Yes. Because I - I didn't see the guy. I didn't see the subject. All I heard  
1017 Officer (Hunt) said was, "I have him. He's in front of - he's in front of me."  
1018 And - 'cause I didn't see him. My attention immediately went to the trailer.  
1019 And - and I thought maybe he's talkin' about the trailer. So that's what - and I  
1020 saw a dog stand in front of the trailer also so I'm like, "Well maybe he's over  
1021 by the trailer somewhere." So that's why I - I pulled in that direction.  
1022
- 1023 Q1: And normally when, ah, during a situation like that or your police training, ah,  
1024 three Officers arrive. One would go to the front, one would go to the left, one  
1025 would go to the right in a fan-out motion. Is that correct?  
1026
- 1027 A: A fan-out motion. Correct.  
1028
- 1029 Q1: Okay. And in this instance that's what you did. You went to the right and  
1030 somebody took the center and - and another Officer went to the left.  
1031
- 1032 A: Yes. Correct.  
1033
- 1034 Q1: Okay. Um, okay. And then you said, ah, earlier that the, ah, the subject had  
1035 then approached - was approaching, ah, Sergeant (Pelletier) and - and Officer

1036 (Hunt). Is that correct?  
1037  
1038 A: Correct.  
1039  
1040 Q1: Okay. On a scale of one to ten, ah, on the subject's aggression level - one  
1041 being not aggressive and ten being aggressive, ah, what would you say the  
1042 subject's aggression level was.  
1043  
1044 A: I would say it was definitely a ten.  
1045  
1046 Q1: Okay. And the, ah, the physical and, ah, physical and the clothing description,  
1047 ah, of the subject - was this a - if you could describe - if you remember in your  
1048 - in your words what - what he was wearing and, um, was this a - what did this  
1049 man look like? Was he, ah, what ethnicity? Was he a short person, tall person?  
1050 If you could describe what - if you remember.  
1051  
1052 A: Ah, I can't really say how tall he was. Um, I mean I can estimate him at  
1053 probably being maybe 5'9" - 5'10". Ah, white male. Um, heavy set. Ah, kind  
1054 of sh- shorter mohawk-ish hair. Um, ah, wearin' all camouflage. Had a  
1055 machete, a knife and a hatchet on him.  
1056  
1057 Q1: And when you say the, ah, he had the, ah, machete, hatchet and stuff like that  
1058 and he - he had it in his hand do you remember if he had a - just one hand on  
1059 it, a right, left hand or?  
1060  
1061 A: His right hand. He had a g- ah, clinched in his right hand.  
1062  
1063 Q1: Okay. And then you had said earlier about your, um, your sight picture. Your  
1064 sight picture at the time when you were - when you had your - your firearm  
1065 raised.  
1066  
1067 A: So there was three times that I raised my - my firearm. The sight picture of  
1068 course bein' a front sight, rear sight, ah, on target. Um, and when I was on  
1069 target I noticed that there was a backdrop of a concrete, ah, culvert or, ah,  
1070 embankment. Um, of course I also knew that there was housing to the left of  
1071 my angle that my rounds would have went was to the - to the Northeast where  
1072 Officer (Pelletier) or Sergeant (Pelletier) and Sergeant (Hunt)'s, ha, Sergeant  
1073 (Pelletier)'s, Officer (Hunt)'s rounds were goin' East. Ah, there was houses to  
1074 the North. The embankment was goin' - goin' to the North, um, and I didn't  
1075 want - my first thought was, "Okay. Well. Concrete embankment." Um, I  
1076 didn't know what exactly what kind of concrete it was. Ah, last thing I wanna  
1077 do was miss. Although I probably wouldn't have missed - was to hit that  
1078 concrete and go into the - to any structure. Um, came down to the ready.  
1079 Subject got closer. Came back on sight again - front sight, rear sight, ah, on  
1080 target. And now my angle is even worse. It's a concrete embankment and now

1081 closer to the houses - to the structures. Um, came down again. Subject got  
1082 even closer and I said, ah, my thought was, "I - I can't wait anymore." Came  
1083 back up - up on sight again - front sight, rear sight, on target. Now, ah, there  
1084 was a slight delay, ah, because now I'm seein' structure, um, and I made a  
1085 decision, "Okay. I'm gonna fire." Right when I made the f- the decision to fire  
1086 that's when I heard Officer (Hunt) and Sergeant (Pelletier) firing.  
1087  
1088 Q1: Okay. And based on your training and experience at the time you weren't in a  
1089 good position to fire your weapon because of, you said, the backdrop, the  
1090 possible ricochet off the concrete and so on.  
1091  
1092 A: Correct. Yes.  
1093  
1094 Q1: Okay. And another question I just had. You - when you exited your vehicle,  
1095 ah, and from your vantage point - when you exited your vehicle where - where  
1096 did - where were you standing? Do you remember where you went when you  
1097 exited your vehicle?  
1098  
1099 A: I exited my vehicle and made my way to the front quarter panel, um, of - of  
1100 just the front of the right front passenger door of, ah, Sergeant (Hunt)'s  
1101 vehicle.  
1102  
1103 Q1: Okay. So you exited your vehicle you were on the right front side which  
1104 would be the passenger front side...  
1105  
1106 A: Correct.  
1107  
1108 Q1: ...of...  
1109  
1110 A: Near the right front.  
1111  
1112 Q1: ...Officer (Hunt)'s vehicle.  
1113  
1114 A: Yes.  
1115  
1116 Q1: Okay. And we had talked several times, ah, and - and earlier you said you had  
1117 collected the - the weapons that the subject had and placed them in the back of  
1118 - of your vehicle.  
1119  
1120 A: Yes.  
1121  
1122 Q1: Okay. Um, we described that - or you had described that as a machete.  
1123  
1124 A: Yes.  
1125

- 1126 Q1: Okay. Um, would you des- still describe it as a machete or - or would you  
1127 describe it - what - is that what your desc- would you describe it as a sword or  
1128 a ma- or a machete? What was your - after...  
1129
- 1130 A: Well.  
1131
- 1132 Q1: Your remembrance of it.  
1133
- 1134 A: Well I'm not a machete expert. But I do remember bein' on - on scene, um,  
1135 and thinking this is more like a sword. Ah, it was a very - very long machete.  
1136 Um, I will - part of me wanted to call it a sword but it was too thick - too wide  
1137 in my opinion to be a sword. 'Cause I'm - I've always thought a sword as  
1138 bein' skinnier. Um, but this is very a - very fat blade. Um, so, um, to me it was  
1139 a sword but I - I would articulate it as being a machete.  
1140
- 1141 Q1: Okay. That's what I was just asking. If - what you want to articulate it as. A  
1142 sword or a machete. That's all.  
1143
- 1144 A: Yes.  
1145
- 1146 Q: Through your training and experiences though you - you're determining it -  
1147 that it was a deadly weapon.  
1148
- 1149 A: A deadly weapon. Yes.  
1150
- 1151 Q1: That's all I had.  
1152
- 1153 Q: As you - as the suspect stands up and then starts approaching Officer (Hunt)  
1154 what were the suspect's actions? Was he - what - what was he then doing with  
1155 the sword - machete - whatever - whatever you wanna call it? What was he  
1156 doing with it? What was his body language? What did he say? What did he do  
1157 at that point?  
1158
- 1159 A: Ah, when - when he stood up, um, other than listen' - watchin' the video, um,  
1160 at the time all I heard him doing was growling. Growling out load like a  
1161 frustrated, threatening growl. Um, now with the s- with the, ah, machete, ah,  
1162 he had it clenched in his right hand, ah, from what I can remember his left  
1163 hand was also clenched in a fighting manner. And he was, um, and I don't  
1164 know how to ar- articulate my words here, um, he was shaking, like, shaking  
1165 his fists, ah, with the machete in the right hand and his clenched left hand.  
1166 From what I could remember he was shaking his fists.  
1167
- 1168 Q: So machete in the right hand.  
1169
- 1170 A: Yeah.



1171  
1172 Q: Clenched fist. Empty handed on his left?  
1173  
1174 A: Empty hand on his left.  
1175  
1176 Q: The - we'll just call it a weapon - sword or machete - up, down, by his side,  
1177 out like an airplane.  
1178  
1179 A: It was...  
1180  
1181 Q: What was...  
1182  
1183 ((Crosstalk))  
1184  
1185 A: It was - it was going down from his side and to his waist and when - as he was  
1186 going from his - down from his side to his waist it was in a shaking manner,  
1187 um, from what I articulate, like, a fighting stance. So, um, ah, I don't know  
1188 how to articulate it. He was goin' like this. So it's just kinda, ah, I don't know  
1189 how to articulate that.  
1190  
1191 Q: So - so shaking his fists up and down in a rapid motion.  
1192  
1193 A: Shaking. Yeah. Shaking his fist up and down in a rapid motion. Yes.  
1194  
1195 Q1: And that's - all that's taken from your vantage point.  
1196  
1197 A: Yes.  
1198  
1199 Q1: Where you're standing on the side of the car.  
1200  
1201 A: Correct.  
1202  
1203 Q1: Okay. And you had said that there was, ah, commands being given.  
1204  
1205 A: Ah, there was commands being given by, um, Officer (Hunt) and Sergeant  
1206 (Pelletier), ah, I gave a couple myself.  
1207  
1208 Q1: Okay. So you clearly heard the commands being giving - being given?  
1209  
1210 A: Yes. Clearly.  
1211  
1212 Q1: Was the subject following the commands?  
1213  
1214 A: No. He was not.  
1215

1216 Q1: Any of the commands?  
1217  
1218 A: No.  
1219  
1220 Q1: Thank you.  
1221  
1222 Q: So he's shaking his fists up and down. Not listening to commands. What does  
1223 the subject do next?  
1224  
1225 A: He just, ah, um, well he starts doin' that after he stands up. And, ah, what he -  
1226 and as he's walking he's shaking his - he's growling and shaking his fists.  
1227  
1228 Q: Walking where?  
1229  
1230 A: He's...  
1231  
1232 Q: Away from the Officers. Towards the Officers.  
1233  
1234 A: He's walking...  
1235  
1236 Q: Lateral movement.  
1237  
1238 A1: Let him finish. Let's not speak over each other just for the recording.  
1239  
1240 A: Oh, okay  
1241  
1242 Q: Walking towards the Officers, away, in a lateral movement, continuing that  
1243 same aggressive hand shaking that you - you had referenced.  
1244  
1245 A: Um, yeah. He was walking, um, I - in a Western direction towards Officer  
1246 (Hunt) and Sergeant (Pelletier).  
1247  
1248 Q: Okay. Just to kinda back up slightly. Did - do you recall or remember seeing  
1249 the patrol lights on either your vehicle or any of the other two - Sergeant  
1250 (Pelletier)'s or Officer (Hunt)'s - lights still active. Emergency lights flashing.  
1251 Do you remember seeing that?  
1252  
1253 A: Yes. They all were on.  
1254  
1255 Q: Okay. And from and back lights?  
1256  
1257 A: Yes. Front and back. Yes.  
1258  
1259 Q: Okay. So from your vantage point it was quite clear that all three of you were  
1260 Officers in a marked patrol vehicle with your lights on, all in uniform.

1261  
1262 A: Yes. Correct.  
1263  
1264 Q: Okay. So as Officer (Hunt) and Sergeant (Pelletier) are giving verbal  
1265 commands the guy then starts to walk towards Officer (Hunt).  
1266  
1267 A: Yes. He does.  
1268  
1269 Q: Okay. Continue describing what the suspect's actions were.  
1270  
1271 A: Um, so the subject's was walking towards Officer (Hunt). Ah, refusing to, um,  
1272 obey any commands of - to drop the hatchet. To stop and drop the hatchet.  
1273 Um...  
1274  
1275 Q: Just for clarification. The same - you - you said the hatchet. Is that the same  
1276 thing that he was holding in his hand?  
1277  
1278 A: Yes. Same thing he was holding in his hand.  
1279  
1280 Q: Okay. Also referenced the sword or machete.  
1281  
1282 A: Yes. The same - same weapon.  
1283  
1284 Q: Okay.  
1285  
1286 A: Um, so he continues walkin' towards, um, Officer (Hunt) refusing to obey any  
1287 commands. So I don't know where we were there.  
1288  
1289 Q: Okay. So he's - the - the subject's no longer obeying commands. If you had to  
1290 estimate a distance from Officer (Hunt) to the subject. He's closed the  
1291 distance now approximately how far away is he?  
1292  
1293 A: Mm, so could you clarify somethin' for me?  
1294  
1295 Q: Sure.  
1296  
1297 A: Are you speaking of the - the time the shooting actually happened?  
1298  
1299 Q: I'm talking from the moment you saw the subject stand up.  
1300  
1301 A: Okay.  
1302  
1303 Q: He had the weapon reference the hatchet, knife, or, ah, sword or machete in  
1304 his right hand. Sergeant (Pelletier) and Officer (Hunt) are giving verbal  
1305 commands and you said he began walking towards them. When he starts

1306 walking towards 'em how - where are we at on distance -wise?  
1307  
1308 A: I'm gonna say 40 - 50 feet.  
1309  
1310 Q: Okay. Does he - he - he - so he continues to o- disobey commands.  
1311  
1312 A: Yes.  
1313  
1314 Q: Does the subject do anything? Does he speed up? Does he slow down? Does  
1315 he turn around? What does he continue to do?  
1316  
1317 A: His, ah, pace of walk, ah, re- remained steady. He - once he got up - stood up  
1318 and started walking his pace didn't change. It - it stayed at a - a constant speed  
1319 if you will.  
1320  
1321 Q: Detective Kadelak.  
1322  
1323 Q1: And still with the weapon or weapons in his hand.  
1324  
1325 A: Still with the - with the weapon in his right hand.  
1326  
1327 Q1: Okay. And at that point did you feel that your life and the - or the life of your  
1328 fellow Officers was in danger?  
1329  
1330 A: I felt there was, um, I felt there was an extreme, um, active, imminent danger -  
1331 threat existing.  
1332  
1333 Q: So as he's closing in do you see him make any movement with his hands or  
1334 the subject say anything back to the Officers?  
1335  
1336 A: Um, like I said before - all I heard him s- doin' was growling. That's what  
1337 brought - that's what caught my biggest attention was an angered growl that  
1338 was comin' from him.  
1339  
1340 Q: Any actions?  
1341  
1342 A: Ah, he was just shaking his hands up and down in a - a what I would depict  
1343 from past experience as bein' motions that were - he wanted to fight.  
1344  
1345 Q: So it was a continuous action that he had. He had the same demeanor - same  
1346 action from the moment he stood up and started walking towards the other  
1347 two Officers he - he did not do anything different outside of the same thing  
1348 that he did the moment he stood up?  
1349  
1350 A: From what I recall. No.

1351  
1352 Q: Okay. And then you - you explained from your vantage point, um, your  
1353 backdrop and all of that - what - shots were fired.  
1354  
1355 A: Yes.  
1356  
1357 Q: How many? Do you recall how many shots you heard?  
1358  
1359 A: I don't re- at the time I didn't recall how many shots I heard. Um, but when I  
1360 was sealin' off the scene I do remember finding maybe five or six, ah, empty  
1361 casings. And like I said that's just - I don't remember exactly how many there  
1362 were. Um, just what I think I remember counting.  
1363  
1364 Q: And based on your - based on your training and experience did - would you  
1365 have ever confronted a guy holding a weapon, ah, machete or sword in this  
1366 instance - would you have ever used anything less lethal? What was your -  
1367 what do you deem somebody holding a machete or a sword?  
1368  
1369 A: As an imminent danger - imminent threat actively. Um, so as far as less lethal  
1370 goes, um, ah, if it was something long distance that we had available  
1371 immediately it might be somethin' we could try but in this case there just  
1372 wasn't any time.  
1373  
1374 Q1: So the subject didn't - from the time you got on scene til the shooting - the  
1375 subject didn't allow you any time to reason with him or make any decisions or  
1376 anything like that?  
1377  
1378 A: No.  
1379  
1380 Q: Do you have a - a - a rough estimate, ah, from the moment you all arrived on  
1381 scene to the moment subject stood up, disobeyed commands, started, ah,  
1382 approaching the other two officers. Ah, do you have about a timeline of how  
1383 much time had lapsed?  
1384  
1385 A: Um, probably estimating 20 to 30 seconds.  
1386  
1387 Q: Okay. Do you remember - after the shooting - do you remember who radioed  
1388 for fire or medical?  
1389  
1390 A: Um, Officer (Hunt) did.  
1391  
1392 Q: Okay. Did any - you or the other two Officers on scene - ah, render any aid?  
1393  
1394 A: No. We did not.  
1395

1396 Q: Okay. Want that later. So call away for medical. Ah, I think you - you had  
1397 kinda described that you were gonna keep yourself busy. Ah, and you walked  
1398 around to Sergeant (Pelletier)'s patrol vehicle and noticed that there were  
1399 casings on the ground.  
1400  
1401 A: Um, to the left of Officer (Hunt)'s vehicle. To the right of Sergeant  
1402 (Pelletier)'s vehicle. Correct.  
1403  
1404 Q: Okay. When you did that you identified that there were casings on the ground  
1405 and you put the - you put police tape on them or near them.  
1406  
1407 A: Ah, they started to be out around them in a circular manner kinda like a cup  
1408 would. But...  
1409  
1410 Q: And what did you do that for?  
1411  
1412 A: Just to have people not step on 'em or disturb 'em.  
1413  
1414 Q: So to preserve the evidence?  
1415  
1416 A: Yes.  
1417  
1418 Q: Okay. Did you or anyone deliberately and or accidentally alter the crime  
1419 scene?  
1420  
1421 A: No.  
1422  
1423 Q: Okay. Do you - did you discuss it with anyone?  
1424  
1425 A1: Discuss what?  
1426  
1427 Q: Discuss the incident.  
1428  
1429 A1: Y- I don't count.  
1430  
1431 A: Oh, you don't count? No.  
1432  
1433 Q: Ah, did you write any supplemental report?  
1434  
1435 A: N- no. Not yet.  
1436  
1437 Q: Okay. Is there anything that the subject could have done to change the  
1438 outcome of the incident?  
1439  
1440 A: The subject could have agreed to obey commands. Drop the hatchet. And, ah,

1441 we could have continued in a more civil manner. Yes.  
1442  
1443 Q: Okay.  
1444  
1445 Q1: (Unintelligible).  
1446  
1447 Q: Detective Kadelak.  
1448  
1449 Q1: Ah, as far as a - a supplemental report. This will act as a supplemental report.  
1450 Okay? Your interview will be you report so you won't be writing any reports  
1451 for the incident. And as far as we said earlier, um, as far as the - the crime  
1452 scene, ah, deliberately or accidentally alter the crime scene - so you did tape  
1453 the area off. Correct?  
1454  
1455 A: Yes sir. Yep.  
1456  
1457 Q1: You did mark some shell casings that were there that you found.  
1458  
1459 A: Correct.  
1460  
1461 Q1: Okay. You collected you said a machete or sword-type weapon.  
1462  
1463 A: Yes.  
1464  
1465 Q1: A hatchet.  
1466  
1467 A: Yes.  
1468  
1469 Q1: And a knife.  
1470  
1471 A: Yes.  
1472  
1473 Q1: Okay. And then you collected them from near the deceased subject that you  
1474 described.  
1475  
1476 A: Yes.  
1477  
1478 Q1: And then at that point you wrapped them in a sheet that came from the fire  
1479 department that they gave you.  
1480  
1481 A: Yes.  
1482  
1483 Q1: And you secured them in the back of your vehicle.  
1484  
1485 A: Yes.

1486  
1487 Q1: Okay. Ah, also in that sheet could there have been a pair of rubber gloves or  
1488 something from the scene that was in there?  
1489  
1490 A: Um, yes.  
1491  
1492 Q1: Okay. So whatever was collected in the sheet, ah, was collected by you and  
1493 put in the sheet and secured in the back of your patrol vehicle.  
1494  
1495 A: Yes.  
1496  
1497 Q1: Okay. Um, your microphone that was on your vest - your outer carrier that  
1498 records audio, um, that was located in your patrol vehicle. How did it get  
1499 inside the patrol vehicle? From your vest to inside the patrol vehicle. Do you  
1500 recall?  
1501  
1502 A: Yes. I do. Ah, what happened was, um, command staff started arriving on  
1503 scene and the Patrol Lieutenant came to each on of us. Um, and began  
1504 collecting our L3 recorders individually and placed 'em back in the vehicles.  
1505  
1506 Q1: Okay. And who was the Lieutenant that did that?  
1507  
1508 A: Lieutenant (Foley).  
1509  
1510 Q1: Okay. And also the police lights you said when you arrived on scene were all  
1511 flashing on the police cars.  
1512  
1513 A: When I arrived on scene they were all flashing on all the police cars. Correct.  
1514  
1515 Q1: Okay. Are you aware or do you know who, ah, had turned the police lights off  
1516 on the vehicles or if they were turned off?  
1517  
1518 A: It was after we sealed off the area, um - um, ah, got the weapons, um, in a safe  
1519 condition. Um, that the lights actually started bothering me and I remember  
1520 sayin', um, sayin' to (Pelletier), "Do you mind if we turn some of these lights  
1521 off?" I mean, 'cause they were actually startin' to bother me 'cause they just  
1522 started to mess with my eyes. Um, he said, "Sure." So that - about - after the  
1523 scene was all secure and all what not that's when we turned off the lights.  
1524  
1525 Q1: Okay. Did you turn off the lights in your patrol car?  
1526  
1527 A: Um, I believe so. Yes.  
1528  
1529 Q1: Okay.  
1530



1531 A: The lights but not the L3 at that time.  
1532  
1533 Q1: Okay. Ah, I have nothing else to add.  
1534  
1535 Q: Is there anything else you wish to address, ah, that we didn't discuss during  
1536 the interview?  
1537  
1538 A: No.  
1539  
1540 Q: Ah, do you have any questions?  
1541  
1542 A1: I have a clarifying line of questioning. Is this a good time or should I wait?  
1543  
1544 Q: Clarifying for us or for...  
1545  
1546 A1: For him.  
1547  
1548 Q: Ah, pertaining to the incident or?  
1549  
1550 A1: Correct.  
1551  
1552 Q: Um, we can take a break if it's something you wanna discuss with him prior?  
1553  
1554 A1: Mm-mm.  
1555  
1556 Q: Okay.  
1557  
1558 A1: I don't need to.  
1559  
1560 Q: Okay.  
1561  
1562 A1: Ah, is this a good time though?  
1563  
1564 Q: Oh, yeah. Yes. Yeah. Yeah. This is closing. Yeah.  
1565  
1566 A1: We've heard the term hatchet used multiple times. Was there a hatchet  
1567 involved in this incident?  
1568  
1569 A: Now there was a - there was an item on him that was sheathed that I can only  
1570 describe as a hatchet. I never - never unsheathed it to see if it was actually a  
1571 hatchet. It was just a hatchet form.  
1572  
1573 A1: 'Kay.  
1574  
1575 A: Um...

1576  
1577 A1: So earlier when you first started your narrative Officer Hudspeth you  
1578 indicated that there was a hatchet across his lap. What was really sitting across  
1579 his lap?  
1580  
1581 A: Oh, ah, I might have - might have got that confused. It was actually a machete  
1582 that was sittin' straddling - sittin' across his lap.  
1583  
1584 A1: So the hatchet that was found at the scene was never in the suspect's hand.  
1585  
1586 A: No.  
1587  
1588 A1: So the weapon he was brandishing was not a hatchet.  
1589  
1590 A: No.  
1591  
1592 A1: 'Kay. That's all I had. Thank you.  
1593  
1594 Q: Okay. Officer Hudspeth do you have anything?  
1595  
1596 A: No.  
1597  
1598 Q: Okay. The time is 1139. We will be going off record.  
1599  
1600  
1601 The transcript has been reviewed with the audio recording submitted and it is an accurate  
1602 transcription.  
1603 Signed\_\_Detective Andrew Reed #7325 04/13/2020\_\_\_\_\_

1  
2  
3  
4  
5  
6  
7  
8  
9  
10  
11  
12  
13  
14  
15  
16  
17  
18  
19  
20  
21  
22  
23  
24  
25  
26  
27  
28  
29  
30  
31  
32  
33  
34  
35  
36  
37  
38  
39  
40  
41  
42  
43  
44  
45

**INTERVIEW WITH OFC. WILLIAM HUNT**  
**Q=Det. (Andrew) Reed**  
**Q1=Det. Stephen Kadelak**  
**A=Ofc. William Hunt**  
**A1=Tosca Henry**

Q: Okay, today's date is January 30th of 2020. The current time is 1243 hours. My name is Detective (Andrew) Reed -- R-E-E-D -- badge number 7325, with the Arizona Department of Public Safety Special Investigations Unit. Also with me is DPS SIU Detective?

Q1: Stephen Kadelak, badge number 6573.

Q: This is a voluntary criminal interview with Officer William Hunt.

A: Uh, my - yes. Uh, my name is William Thomas Hunt and, uh, my badge number is 461.

Q: And he is with the Sedona Police Department. Office Hunt is represented by attorney?

A1: Tosca Henry. That's T-O-S-C-A, H-E-N-R-Y.

Q: Who is present with us, as well. Uh, the interview pertains to an officer-involved shooting that took place on Monday, January 20 at 20- uh, January 20th of 2020 at approximately 1332 hours near 55 Newcastle Lane in Sedona, Arizona involving Sedona police officers with the department. Uh, the interview is taking place at Attorney Henry's office located at, uh, 1003 North Main Street in Cottonwood, Arizona. The corresponding DPS report number is Ida 20003903. Uh, Officer Hunt, do you understand the interview is recorded and criminal in nature, however, completely voluntary?

A: Yes.

Q: Uh, along with that, do you understand you are free to leave at any time, and you are not compelled to any - uh, to answer any questions, and you may discuss any question and - and/or your answer with the attorney in private as needed?

46  
47 A: Yes.  
48  
49 Q: Okay. Uh, Officer Hunt, have you had the opportunity to review your dash  
50 cam audio footage or anything else that was on your person or patrol vehicle  
51 in reference to the incident we're discussing?  
52  
53 A: I have.  
54  
55 Q: Okay. After reviewing the footage and listening to the audio, are you  
56 comfortable proceeding?  
57  
58 A: Yes.  
59  
60 Q: The first series of questions will be, uh, biographical information. Um, so can  
61 I get your full name, please?  
62  
63 A: Yes, uh, full name, legal name is William Thomas Hunt, last spelling H-U-N-  
64 T.  
65  
66 Q: And you go by Bill?  
67  
68 A: I go by Bill.  
69  
70 Q: Okay. And what, uh, what was your age at the, uh, time of the incident?  
71  
72 A: My age?  
73  
74 Q: Correct.  
75  
76 A: I'm 55 years old.  
77  
78 Q: Okay. Do you wear glasses or contacts?  
79  
80 A: I do. I wear glasses.  
81  
82 Q: Near-sighted or far-sighted?  
83  
84 A: Both. They're bifocals.  
85  
86 Q: Okay. You wear them all the time?  
87  
88 A: Oh yeah.  
89  
90 Q: Are you right-handed, left-handed, ambidextrous?

91  
92 A: I'm right-handed.  
93  
94 Q: Okay. And then some, uh, employee - uh, employment information. What is  
95 your occupation?  
96  
97 A: I'm a police officer with the City of Sedona Police Department.  
98  
99 Q: Do you know the address?  
100  
101 A: Yeah, it's 100 Roadrunner Drive, uh, Sedona, Arizona 86336.  
102  
103 Q: And a telephone number?  
104  
105 A: It's 928-282-3100.  
106  
107 Q: What's your date of employment?  
108  
109 A: Date of employment? I was employed August 14, 2005.  
110  
111 Q: And you said your rank was a police officer. Uh, can you say your badge  
112 again?  
113  
114 A: 461.  
115  
116 Q: And your call sign?  
117  
118 A: 461.  
119  
120 Q: Okay. Badge number call sign all - always stay the same?  
121  
122 A: Yes.  
123  
124 Q: Okay. Uh - uh, briefly get into your, uh, police experience. When and where  
125 did you graduate or attend the police academy?  
126  
127 A: So on the 15th of August 2005, I began the, um, academy at Northern Arizona  
128 Regional Training Academy, um, which is, uh, abbreviated as NARTA, here  
129 in Prescott Valley. Um, I attended that for approximately 17 weeks. Uh, I  
130 graduated that academy, um, in December 12, 2005. And then I, um, would  
131 ride along. I began my FTO process with, um, I think it was at the time four,  
132 uh, different officers with the Sedona Police Department, um, riding along  
133 with them and then eventually, um, taking my own calls, um, as the FTO  
134 program processed, uh, or moved forward. Um...  
135

- 136 Q: Okay. Have you - have you received any specialized training?  
137
- 138 A: I - I have. Um, after two years on as a patrolman, I went to, uh, motors, and  
139 for approximately eight years, um, I was the traffic guru for, uh, Sedona  
140 Police Department. Um, and within that, I was, um, I went through all three  
141 reconstruction classes. Um, I went to, um, obviously pedestrian bicycle  
142 reconstruction classes. Um, again like I said, and - and I handled, um, pretty  
143 much any and all of the fatality crashes that Sedona had in that eight years.  
144
- 145 Q: Okay. What shift are you assigned to currently?  
146
- 147 A: Right now I'm assigned to squad one, which is the beginning of the work  
148 week, and that for us - we work 12-hour days, and it's Sunday, Monday,  
149 Tuesday and every other Wednesday. And that would be dayshift first part of  
150 the work week.  
151
- 152 Q: Okay. We'll get into, uh, your uniform. Can you describe, uh, just your  
153 uniform, um, to include colors, uh, patches...  
154
- 155 A: Mm-hm.  
156
- 157 Q: ...placards on your vest.  
158
- 159 A: Uh, so just to - to clarify, I wear an internal vest. I don't wear an external vest.  
160
- 161 Q: Okay.  
162
- 163 A: So I have a navy blue, um, what they refer to as an LAPD blue, um, wool  
164 shirt, button down, and a pair of wool pants. Um, again, they're also navy blue  
165 or LAPD blue. Um, I typically wear a long sleeve or a short sleeve, um, just  
166 depending on the weather. Um, on that shirt, uh, what I wear is the se- um,  
167 Sedona, Arizona metal badge, um, and I have my nameplate on there. And  
168 then both shoulder patches are Sedona issued, um, uh, shoulder patches.  
169
- 170 Q: Okay. Were you wearing short sleeve or long sleeve at the time of the  
171 incident?  
172
- 173 A: Short sleeve.  
174
- 175 Q: Okay. Uh, we'll get into your belt and your equipment that you were wearing.  
176 So, uh, describe what kind of belt and holster you had.  
177
- 178 A: Um, so I have a - it's - it's a - it's a all newer belt. Um, I - I apologize. I forget  
179 the name of it, but it's like a leather belt. Um, and we just went in the last 1-  
180 1/2 years, we just went to a level 3, um, holster with a hood. So I apologize

181 for not having the model number or anything like that, but it - this is all - this  
182 was all brought on by our previous chief who just left.

183  
184 Q: The retention is what we needed.

185  
186 A: Yes.

187  
188 Q: Um, so with your duty belt and with the front clasp being the first point of  
189 reference, moving clockwise, so to your right...

190  
191 A: Okay.

192  
193 Q: ...can you describe everything, all pieces of equipment that you have on your  
194 belt?

195  
196 A: Okay, so I have, um, first is my magazine pouches. Um, I have two magazines  
197 - extra magazines directly below my, uh, tummy. Along beyond that is my  
198 handgun, my holster, 'cause I'm right-handed. Beyond that is my, um, class -  
199 my - my collapsible, uh, baton. Then I have a pouch right in the middle in the  
200 back that I carry, uh, like rubber gloves and such like that. Um, and then I go  
201 around to my radio, um, and then I go to my taser, and then I go to a single  
202 pouch handcuff.

203  
204 Q: Okay. We'll move onto your weapon. Is it your personal weapon or duty  
205 weapon?

206  
207 A: No, it's - it's issued by the Sedona Police Department.

208  
209 Q: What's the make and model?

210  
211 A: It is a Glock 17.

212  
213 Q: What kind...

214  
215 A: Nine millimeter.

216  
217 Q: Nine millimeter, okay. Have you made any modifications or armor made any  
218 modifications to the firearm?

219  
220 A: No.

221  
222 Q: Okay. Did you have a tactical light on your weapon?

223  
224 A: No, sir.

225

226 Q: Okay. What type of ammunition? Department ammunition?  
227  
228 A: It's department-issued ammunition, yes, sir.  
229  
230 Q: Okay. Each magazine that - that you have...  
231  
232 A: Mm-hm.  
233  
234 Q: ...is a 17-round capacity magazine?  
235  
236 A: That's correct.  
237  
238 Q: And what do you load those magazines up to?  
239  
240 A: Per policy, our magazines are loaded up to 16, and the one that will be in the  
241 handgun itself will be 16 in the magazine and one in the chamber.  
242  
243 Q: All right. Uh, at the time of the incident, did you have any, uh, any other we-  
244 weapons with - either on you and/or in your vehicle? And if so, which ones  
245 were they?  
246  
247 A: Yes. In the front, uh, in between the two seats is, um, a department-issued  
248 AR15, um, and it was - it's considered patrol ready where is the chamber's  
249 closed with no bullet in the chamber. Um, and then on my passenger seat I  
250 have a paper rack like where I keep all my citations and paperwork. And also,  
251 um, I have my pepper spray. That's, um, on the side over here. Um, along  
252 with that, they had just purchased and, um, I was one of the ones that actually  
253 got trained on it, was a less lethal 12-gauge shotgun, uh, which is to be, um,  
254 signed out in the morning. It's locked up in the back of your car, locked up in  
255 a soft case, if you will, with the bullets, um, on a carrying case. It was on the  
256 butt. It's on the butt, and it - it - it - they offer you the - when you - when you  
257 sign out the gun, you get six rounds. Um, so that was in the back of my  
258 patreo- patrol vehicle locked up.  
259  
260 Q: You have - just a second. Um, (unintelligible).  
261  
262 Q1: I just had a follow-up question or two. Uh, I don't know if you had mentioned,  
263 uh, Bill, what - what are your hours that you work?  
264  
265 A: Six in the morning 'til 6:00 at night.  
266  
267 Q1: Okay. And then as far as you had mentioned your - uh, the other firearm you  
268 had in the back of your vehicle. What did you describe it as, a beanbag gun or  
269 a...  
270



271 A: No, it's, uh, well no. I don't think it's a beanbag. It's, um, it's, uh, considered  
272 a less lethal shotgun, and it - it - it doesn't shoot out beanbags. It has like, uh, I  
273 believe - I don't - I don't - I'm not gonna say, 'cause I don't really know for  
274 sure, but I know it's less lethal.  
275  
276 Q1: Okay. And any of those other, uh, firearms or, uh, less lethal that was in your  
277 vehicle, did you utilize any of those?  
278  
279 A: Other than the one on me, no.  
280  
281 Q1: Okay, so other than your - your, uh, handgun, you didn't utilize any other vee-  
282 uh, stuff that was in your car.  
283  
284 A: That's correct.  
285  
286 Q1: Thank you.  
287  
288 Q: We'll move onto your patrol vehicle. Uh, can you describe, uh, the color,  
289 year, make, model, and vehicle number?  
290  
291 A: Uh, it's - I can tell you it's a black Ford Explorer. It's approximately 2014.  
292 Um, it has about 98,000 miles on it. It does have decals, uh, that say Sedona  
293 Police Department on it. Um, and what else were you looking for?  
294  
295 Q: Vehicle number.  
296  
297 A: Vehicle number 15.  
298  
299 Q: So it's a fully marked patrol vehicle?  
300  
301 A: Yes, sir.  
302  
303 Q: Equipped with, uh, flashing...  
304  
305 A: Overhead.  
306  
307 Q: ...blue lights and siren?  
308  
309 A: Yes, sir, overhead, um, overhead light bar, um in the front push bar over light,  
310 uh, lights and also in the back.  
311  
312 Q: Okay. Was all of the police equipment in the vehicle properly working?  
313  
314 A: Yes.  
315

316 Q: You doin' okay?  
317  
318 A: Yeah.  
319  
320 Q: Push on? Okay. So I'll briefly talk to you about from the time that you logged  
321 onto to prior to the incident.  
322  
323 A: Mm-hm.  
324  
325 Q: Okay? Did you - you logged on around 6 o'clock?  
326  
327 A: Yes.  
328  
329 Q: Did you make any traffic stops, answer any calls for service?  
330  
331 A: Uh, no traffic stops to my recollection. Um, I did assist with, um, a call of a  
332 motorcycle down, um, that turned out to be the gentleman just lost his footing  
333 and the bike fell over, so it was really - I didn't even get out of the car. We  
334 responded. We figured it out, and I moved on. Um, I then dealt with a couple -  
335 um, we have on the weekends and on holidays we have a rush of people, uh,  
336 to - to do hikes here in Sedona, so a couple of my calls prior to were checking  
337 the local heavy areas where we have a lot of parking issues. Um, one being  
338 Soldier's Pass trailhead and the other one being Back O Beyond, which is  
339 about the most southeast, uh, to the city limits.  
340  
341 Q: Okay.  
342  
343 A: For us.  
344  
345 Q: During the time you were driving around in your fully marked car and if you  
346 got out of it, did other members of the community, other people that you  
347 interacted with, citizens, recognize you to be a police officer either outside or  
348 in your vehicle?  
349  
350 A: Yes.  
351  
352 Q: Okay. Um, so now, uh, I'll talk to you about things leading up to the incident.  
353 Uh, with you during your patrol time, did you have a civilian observer,  
354 another officer, or K9 officer or a canine or K9 officer riding with you in the  
355 patrol vehicle?  
356  
357 A: No, sir.  
358  
359 Q: Okay. Um, when- where was your location at, at the time of the incident when  
360 you received the first call?

- 361  
362 A: My location was in the north dirt parking lot, of the s- public library which is  
363 on White Bear Road off of Dry Creek, um, on the west side of town.  
364
- 365 Q: Approximately how far away is that from the subsequent call?  
366
- 367 A: Probably four to five miles.  
368
- 369 Q: Okay. Uh, when you received the call relating to this incident, how did you  
370 receive it?  
371
- 372 A: Uh, I received it as - initially as a hot tone which is our - our way or  
373 dispatcher's way of getting everybody's attention. In other words hey, we  
374 have an emergency traffic gonna come across the air. We now need your  
375 attention, so we call it our hot tone. Um, received a hot tone, um, and then,  
376 um, our dispatcher, (Adam), uh we had, uh, two dispatchers on at the time. I  
377 re- recognize (Adam)'s voice, came across and advised of a subject, um,  
378 believed to be wearing camo clothes, uh wielding a machete, acting strangely.  
379 Um, in the parking lot - well it's - it's really a driveway. It used to be a  
380 parking lot, but it's now a driveway for a private resident at 55, um, New  
381 Castle, which is on the east side. And just to be clear, the way the city is  
382 divided up, I - I just want you to be clear that I am primarily the eastside  
383 officer, and another officer is responsible for the west side calls. But when  
384 there's one person on vacation, we split the city in half and then we  
385 technically back each other up. So we're from one side of the city to the other  
386 side of the city.  
387
- 388 Q: When you received the information, what did the dispatcher provide as far as  
389 information, what call you were going on, um, any - any - any information the  
390 dispatcher relayed to you?  
391
- 392 A: Yeah, the - the dispatcher relayed that, um, the caller was stating that there  
393 was a male subject, um, wielding a, uh, machete. Um, there was - he was  
394 acting, um, acting and yelling, um, strangely on the property. Um, at one  
395 point, uh, and I - uh, for me I learned to turn the siren off sometimes on code  
396 3's, because it's difficult sometimes to hear the dispatch. But at one time it  
397 sounded as if the gentleman was approaching the home, um, from - based off  
398 the caller. Uh, he was described as a large male. Um. He had a mohawk He  
399 was wearing camouflage clothes, um, and he was carrying a stick with what  
400 appeared to be feathers hanging off of it. Um, and...  
401
- 402 Q: Is that based on the information from the caller?  
403
- 404 A: Yeah, mm-hm.  
405

406 Q: Okay.  
407  
408 A: Yep. And so okay, and that's basically what I got for the most part.  
409  
410 Q: Okay. You, uh, referenced code 3.  
411  
412 A: Yes.  
413  
414 Q: Explain what that is.  
415  
416 A: Okay. Code 3 is, um, that is when you're going lights and sirens to, uh, to a  
417 call, um, an emergency call. We don't necessarily always go code 3, but that's  
418 the mixture of lights going, all your emergency lights going, and your siren.  
419  
420 Q: When you received the call, your interpretation warranted you needed to get  
421 there quickly?  
422  
423 A: Yes.  
424  
425 Q: Okay. Uh, and I just wanna go back to one other thing that I - I did not clarify.  
426 Did you have any - on your uniform did you have any, um body cams that you  
427 were wearing, any dash cam, any microphone, recording device, anything?  
428  
429 A: We have what's called an L3 system whereas the camera, um, is located on  
430 the windshield of the car, and I have a small mike that I carry on my pocket  
431 that is synched to the - to the L3 system. Um, so it would share basically my  
432 name, um, and you would hear audio connected with the video.  
433  
434 Q: And when does that get activated?  
435  
436 A: S- well, there's a couple different ways. You can activate it by the mike. It has  
437 a switch. Um, you can activate it by hitting record on, uh, on the screen that's  
438 on the dashboard, or it's automatically activated when I go, um, lights and  
439 sirens.  
440  
441 Q: All right. Detective Kadelak?  
442  
443 Q1: And, uh, you had said that you had received a call about a person with a, uh, a  
444 weapon, and you were responding to it, and you - you described some  
445 clothing and stuff like that. So you received the initial call and then while  
446 you're responding to the incident, you were receiving additional information  
447 to update the call?  
448  
449 A: Yes, but very minimal.  
450

451 Q1: Okay. And that was coming across your police radio in your car?  
452  
453 A: Yes, correct.  
454  
455 Q1: That's how you're receiving it?  
456  
457 A: That's correct.  
458  
459 Q1: Okay.  
460  
461 Q: So as - as you're responding, you start to arrive on scene. Daylight, dusk,  
462 describe the - the lighting condition.  
463  
464 A: Uh, it was daylight. Um, partially cloudy. I don't want to say it was cloudy,  
465 but it was - it wasn't our typical normal Arizona sunshine. Um, and, uh,  
466 obviously wintertime, dry.  
467  
468 Q: Okay. Describe - describe the scene as you arrived.  
469  
470 A: Okay. So as I'm arriving, I'm the first one on scene. Um, and, uh, I pull in,  
471 and it's a dirt road -- it turns to a dirt road. Um, it goes back into some private  
472 property. Um, it - it turns to the left, and there's a concrete wash driveway that  
473 you have to enter through, um, because it's connected to the creek, Oak Creek  
474 Canyon, so, um, you drive through this, um, dip, concrete dip, and as you pull  
475 to the top, um, there - it - it opens up. Um, I - at first I wasn't able to see a lot,  
476 because there was a man in a pickup truck trying to exit the address at the  
477 same time, but eventually he moved out of my way, and I was able to pull up  
478 on top. And in front of me, um, was a pole, a little post, and it said, "55 to the  
479 left." And I - I don't remember what to the right was, but it said another  
480 address to the right. Once I saw the 55, I focused on that. As I turned to the  
481 right - or the left and started pulling into the parking lot, um, it's a dirt parking  
482 lot, um, with some mature trees in the center. Um, it used to be an old - um, it  
483 used to be an old apartment building which now was purchased by a single  
484 owner and his parents both live there. Um, and so as I pulled in, um, and got  
485 behind the truck, I observed a gentleman sitting on a concrete wall, barrier  
486 wall, which runs alongside the Oak Creek Canyon, um, and that gentleman  
487 there fit the description of what I had received, uh, during the initial dispatch  
488 to the call.  
489  
490 Q1: Okay. And then, uh, was there a large amount of vehicle traffic in that area?  
491  
492 A: No.  
493  
494 Q1: It's - uh, is it - you're describing it as sort of a remote area?  
495

496 A: It's a remote area.  
497  
498 Q1: Okay. Is there a volume of pedestrian traffic in that area?  
499  
500 A: Uh, there's homes. There's - there's homes. There's, um, so but it's not - it's  
501 not a - it's not a popular place for somebody to be walkin' around.  
502  
503 Q1: No sidewalks or anything?  
504  
505 A: Yeah, no - no - no sidewalks.  
506  
507 Q1: Okay.  
508  
509 A: No, this is private property.  
510  
511 Q1: Okay. And a moment ago you said you had pulled in there, and then you saw  
512 a male subject, is that correct?  
513  
514 A: Mm-hm.  
515  
516 Q1: Sitting on - on the wall...  
517  
518 A: Mm-hm.  
519  
520 Q1: ...in the back right there.  
521  
522 A: That's correct.  
523  
524 Q1: Did you recognize this person as somebody that you ever had prior contact  
525 with or...  
526  
527 A: No.  
528  
529 Q1: ...talked to before?  
530  
531 A: Nope.  
532  
533 Q1: You didn't recognize him as anybody you've dealt with before?  
534  
535 A: No.  
536  
537 Q1: Thank you.  
538  
539 Q: So we'll get into the incident.  
540

541 A: Okay.  
542  
543 Q: You arrive. Are you first on scene? Where are you at, um, in correlation to the  
544 other officers?  
545  
546 A: We all arrived about the same time, but I'm primary, so I was ahead of  
547 everybody. So, uh, my car was first in line, and then Officer Hudspeth was  
548 behind me, and then Sergeant Pelletier was behind him, and so I'm here, and  
549 they fanned behind me. So, um, that's what I know of their vehicles and my  
550 vehicle.  
551  
552 Q: When you placed your vehicle did - were you aware of dash cam and placing  
553 it to...  
554  
555 A: Yes.  
556  
557 Q: Okay.  
558  
559 A: Yes.  
560  
561 Q: Where - why did you do that?  
562  
563 A: Um, because according to what I was being told on the radio in coming over  
564 there, um, this could have turned out to be, excuse my language, a shit show.  
565 And so I needed to get it on video. I needed to make sure that my video was  
566 filming what it could.  
567  
568 Q: So as you arrive on scene, you - you park your patrol vehicle. You exit your  
569 patrol vehicle, and then what do you - what - what does the suspect do? What  
570 do you do?  
571  
572 A: Okay, so as I put the car in park after I figured out the camera angle and such,  
573 um, as I'm exiting, I can already see that this gentleman in front of me on the  
574 wall has a large knife type object, whether it be a machete or a sword. I just  
575 saw the large knife. So at that point in time, as I was exiting my vehicle, um, I  
576 was also drawing my weapon. We were probably 25 feet in distance from the  
577 front of my car to the subject sitting on the wall. As I exited my vehicle, I  
578 immediately started to give orders, uh, verbal commands to the subject, um, to  
579 put the weapons down off the side. Um, one other thing that immediately  
580 came to my mind was on his right side was the large walking stick with the  
581 feathers hanging off of it. So that in my mind confirmed that whomever the  
582 person was that we were looking for at that time, this was him. This - he's got  
583 the stick. Um, he was also dressed in what I kinda define as, um, wilderness, a  
584 survivalist in the wilderness, camouflage. Um, we were - he was reported to  
585 have a mohawk. He had a small mohawk. Um, and his pants seemed to be

586 cuffed up. He had like work boots on with white socks, and he had this, um,  
587 vest on. And the vest appeared to be - it had a big patch on the back of it, but  
588 it tabeer- appeared to be like a survival vest type thing, um, meaning, you  
589 know, something you would see a hunter wearing or somebody out in the  
590 woods in the field. Um, again I began to give verbal commands to put the  
591 weapon to his side, um, show me his hands. I wanted to clearly see his hands.  
592 Show me the weapon. Um, at one point he confronted me, and he had asked  
593 me - um, he - I - I guess you'd say he challenged me, because he - he said to  
594 me, "And if I don't..." I believe he said, "Are you gonna shoot me or what are  
595 you gonna do?" And I didn't answer that question. Um, it's not appropriate to  
596 answer that question like that. So he immediately got up and began a very fast  
597 pace, um, and I'm like - I'm trying to think of the right words. He - he began  
598 to come at me. And it was extremely clear that he was coming at me. He was  
599 focusin' on me. Um, the other officers were, as well, giving verbal commands.  
600 I was giving verbal commands. Um, he did raise the, uh, machete over his  
601 head and was comin' at me at a quick pace. And at that moment, um, I really  
602 felt that this was an in- intimate threat to not only myself but to the other  
603 officers that were on scene as well as the man and woman that were on the  
604 property.

605  
606 Q: Okay. I'm gonna clarify some things.

607  
608 Q1: Okay, go ahead.

609  
610 Q: When - when you were - when you initially arrived, was the subject sitting or  
611 standing?

612  
613 A: He was sitting on the wall chanting.

614  
615 Q: Chanting. Do you remember any - any statements that he made, uh, prior to  
616 challenging you?

617  
618 A: No. He was making what I believe was like either growling or howling noises.

619  
620 Q: Okay. And then he stood up.

621  
622 A: Quickly stood up.

623  
624 Q: And at that point describe what's in his hands or what he has with him.

625  
626 A: At that point in time, uh, he has, um, he ha- he - he had the s- the machete,  
627 um, and he had both his hands on the handle part of it. Um, and when he -  
628 when he did raise up, it was clear to me that on his righthand side he had an  
629 axe inside of a um pouch, I guess we'll call it. Um, and that - that's what I  
630 saw.



631  
632 Q: On a scale of 1 to 10, 1 not being aggressive and 10 being very aggressive,  
633 what would you rate his aggression level?  
634  
635 A: Ten.  
636  
637 Q: And when you s- when you saw the machete that you had referenced or  
638 sword, what do you view that weapon as?  
639  
640 A: A deadly weapon.  
641  
642 Q: Okay. And you began - you drew your, um, your department-issued handgun?  
643  
644 A: I brought my pistol up to not a resting position but I based - I brought my  
645 weapon up to chest level.  
646  
647 Q: Okay. At what point or what action did the subject do to make you have a  
648 clear front site? What prompted you to get on line with the subject?  
649  
650 A: He was gettin' close, a lot closer quickly with the sword or the machete in a  
651 position where if he chose to sprint, he was approximately 200 to 250 pounds,  
652 and I know from my training and experience, had I waited any longer, he  
653 would not have stopped. The momentum would have carried him into me, um,  
654 whereas I or my sergeant who was directly to my left, um, would have been  
655 either fatally injured or, um, injured period.  
656  
657 Q: Detective Kadelak.  
658  
659 Q1: Um, you said that when you showed up, you were giving - you were giving  
660 him commands to - to put the stuff aside?  
661  
662 A: Yes, sir, I was giving him verbal commands.  
663  
664 Q1: Okay. And did you hear any other, uh, officers giving him commands, as  
665 well?  
666  
667 A: Yes, I did.  
668  
669 Q1: Okay. And, um, was the subject obeying any commands?  
670  
671 A: No.  
672  
673 Q1: Not at any time?  
674  
675 A: Not at any time.

676  
677 Q1: And when you described the, uh, the machete and the sword, um, you had said  
678 when you pulled in - in there, you were about 20, to 25 feet away. He was in  
679 front of your vehicle.

680  
681 A: Yes.

682  
683 Q1: And at 20 to 25 feet away, this machete or sword that you're talking about,  
684 was that large that you identified it right at that point from that distance.

685  
686 A: That's correct.

687  
688 Q1: Okay, so it was a larger...

689  
690 A: Yeah, I would say it's probably approximately 3 feet long.

691  
692 Q1: Okay.

693  
694 A: The blade itself.

695  
696 Q1: And then when we get to the point that you say that he is - uh, he had an axe  
697 on his right side in a sheath, I believe...

698  
699 A: Mm-hm.

700  
701 Q1: ...and then you said, um, he's approaching - he's approaching you, um, with  
702 the - the sword and the machete that you described and, um, you're showing  
703 us here with your hands. Can you tell us whe- was it in his right hand or left or  
704 both or how?

705  
706 A: When he approached me, when - when he immediately got off that wall and -  
707 and got to his feet, um, from sitting, he grabbed the sword or machete in both  
708 his right and left hand, um, they cupped it - he cupped it as if he could get  
709 more power to swing it, to have both of his arms' leverage, and then he raised  
710 it over his head, which is when I was able to see his arms weren't down. They  
711 were up like this, um, in, uh, in an attacking, um, stance, what I would  
712 consider an attacking stance. And that's why I could clearly see the axe on his  
713 righthand side, because he had lifted his arms up above his head with both  
714 hands on the handle of the - the sword or machete, whatever determined,  
715 whatever it is.

716  
717 Q1: Okay, so right as you're describing, showing me here, right and left hand both  
718 on the - on the handle.

719  
720 A: That's correct.

721  
722 Q1: And then in the center of his body he has both hands raised over his head with  
723 the sword or machete in it.  
724  
725 A: That's correct - that's correct.  
726  
727 Q1: And at that point then he's moving towards you?  
728  
729 A: That's correct.  
730  
731 Q1: Thank you.  
732  
733 Q: As this is happening, where - where are you standing at?  
734  
735 A: I am standing directly next to my driver's door. The door is closed, but that's  
736 where I'm standing.  
737  
738 Q: Did you move at any point during the remainder of that incident?  
739  
740 A: Yes.  
741  
742 Q: Okay.  
743  
744 A: Uh, so after my training kicked in and I mean it kicked in, and, um, I fired two  
745 rounds to the chest, okay? Um, go ahead.  
746  
747 Q: Okay, give me...  
748  
749 A: I'm just...  
750  
751 Q: Um, from where the suspect was standing when he started to charge you...  
752  
753 A: No, I did not move.  
754  
755 Q: Okay.  
756  
757 A: Sorry, I didn't understand your question.  
758  
759 Q: You remained at the driver's side?  
760  
761 A: That's correct.  
762  
763 Q: Okay. He started to - how did you describe, uh - uh, a brisk walk?  
764  
765 A: He continued to aggressively walk towards me.

766  
767 Q: Okay. At that determination, you - what was your thought process then?  
768  
769 A: My thought process was he's gonna attempt to kill me.  
770  
771 Q: And what did you do?  
772  
773 A: I fired my weapon and shot twice in the chest.  
774  
775 Q: So you shot two times?  
776  
777 A: Yes.  
778  
779 Q: Were you - were you aiming at - where were you aiming at?  
780  
781 A: His chest.  
782  
783 Q: Center?  
784  
785 A: Yep, center mass.  
786  
787 Q: Kay. Did you have - did you have any - on your gun, did you have one-handed  
788 - two handed grip?  
789  
790 A: Two handed.  
791  
792 Q: Any uh tactical light engaged?  
793  
794 A: No.  
795  
796 Q: What was your - what was the backdrop to?  
797  
798 A: The creek, the wall. Um, uh, there were a few mature trees approximately 3  
799 feet in diameter.  
800  
801 Q: So your - through your training and experience, everything that you've  
802 learned on the range and the years that you've been doing this, what -- was  
803 that a, uh, a good backdrop?  
804  
805 A: Yes.  
806  
807 Q: Okay. When you initially shot, was it two sequential shots?  
808  
809 A: That's correct. Um, just - just exactly like my training. Um, in a threat  
810 situation like that, um, taught to shoot two consecutive rounds to the chest and

811 I did. That's exactly what I did.

812

813 Q: How did - how did he react to...

814

815 A: So that - at that point the only reason why I shot two rounds was because he  
816 had seemed to stop. Um, he wasn't moving forward anymore, and so at that  
817 point in time I waited to see what the next move was gonna be. And during  
818 that time, he basically started to turn. He stopped, and he started turning to the  
819 right, and he then fell, um, on the ground. He fell to the ground face first back  
820 up. Like his backside was up, and his face was down.

821

822 Q: And what was your intent when you used your weapon?

823

824 A: To stop the threat, the imminent threat.

825

826 Q: Following your two shots, did you do what our training is of a tactical reload,  
827 drop your magazine, reload at all? Did you reholster your gun?

828

829 A: No. Once - once the gentleman went down, I holstered my weapon, um, and  
830 began notifying dispatch of what just took place. Um, in other words I got on  
831 the radio. I advised dispatch shots were fired. Um, I then, uh, talked with, um,  
832 my sergeant who was to the left of me and basically discussed okay, we're -  
833 we're still givin' commands. Show me your hands - show me your hands -  
834 show me your hands. I'm not 100% sure he's not fakin' it. Um, so I discu- I  
835 discussed going around the backside of my sergeant and moving forward with  
836 cover from my sergeant, and I removed what was at that time visible on the  
837 person's left-hand side. I could see the - the handle of the ma- um, the  
838 machete or sword or whatever it was. So I wanted to eliminate that possibility  
839 of him getting that weapon again. Um, and so I walked over, came around,  
840 secured the weapon, and basically slid the weapon behind me, um,  
841 approximately five or six feet out of, um, out of control, out of - out of the  
842 ability the - of the suspect if he was, in fact, faking, he could not grab the - the  
843 knife again.

844

845 Q: So when you - I know you ch- at the end you just referenced the knife. The  
846 weapon that you're referencing is what he was holding in his two hands?

847

848 A: The machete, yes, sir.

849

850 Q: Okay. From the time you arrived on scene, initially saw the suspect or subject,  
851 got out of your car, he charged you, you fired two shots. What was the time  
852 difference from him charging you to you firing the shots?

853

854 A: Um, maybe two or three minutes. It...

855

856 Q: Did you have - did you have any opportunity to use any leth- less lethal?  
857

858 A: No - no. From the moment the contact was made, um, there was no - he got up  
859 and he started moving. No, there was no time.  
860

861 Q: And why - why was there no time?  
862

863 A: Because of his aggression as he approached me. Um, in the position of his,  
864 um, the merced - the machete up over his head with both hands, there was no  
865 time to get, um, a leth liesel - lethal weapon out and be effective now within  
866 the distance that he would have had gained on me at that point in time.  
867

868 Q: Detective Kadelak, do you have anything?  
869

870 Q1: Uh, let me look. And when you were on location, were there other officers  
871 there with you that you recognized at the time?  
872

873 A: Yes.  
874

875 Q1: Okay. And that - would that be, uh, (Hudspeth) and Sergeant Pelletier?  
876

877 A: That's correct.  
878

879 Q1: Okay, and they were also on scene with you?  
880

881 A: That's correct.  
882

883 Q1: Okay. And during this time when the subject's approaching you with the - the  
884 - machete or the - the knife above his head, did you - did, uh, did you feel that  
885 your life and the life of other officers were in danger?  
886

887 A: Absolutely. Along with the folks that life there.  
888

889 Q1: Okay, thank you.  
890

891 Q: So following the shooting, uh, I - I know you me- referenced something about,  
892 uh, calling for medical attention? Do you remember who did that?  
893

894 A: I did.  
895

896 Q: Okay. And that was done by cell phone? Radio?  
897

898 A: By radio.  
899

900 Q: Okay. To back up just, uh, just a little bit. When you're arriving on scene we-

901 were your flashing red and blue emergency lights activated?  
902  
903 A: Yes, absolutely.  
904  
905 Q: Did they remain activated the entire time?  
906  
907 A: Yep.  
908  
909 Q: Was there any question that - that anybody in there within that area of 55  
910 Newcastle Lane knew that you were a police officer? Was there any, uh, any  
911 reason for...  
912  
913 A: There's no...  
914  
915 Q: ...nobody - for anybody to believe not, that you were not a police officer?  
916  
917 A: Nope.  
918  
919 Q: Okay. Uh, following the shooting the suspect or the, uh, subject dropped to  
920 the ground. Did you and/or anyone else as far as the officers render any first  
921 aid?  
922  
923 A: I attempted to check to see if there was a pulse. Um, I would say no, other  
924 than re- because other than responding the fire department.  
925  
926 Q: Okay. Did you or anyone deliberately or accidentally alter the crime scene?  
927  
928 A: No.  
929  
930 Q: Following the shooting as you're - um, as - as medical is there, fire is there,  
931 uh, rendering aid, um, what were you doing in the meantime?  
932  
933 A: I remained at the side of the subject on the ground. Um, not only was I, um,  
934 directing the fire department, um, to like check to see what their machinery,  
935 um, if, you know, we had, uh, somebody that needed more assistance. Um, but  
936 I also could hear, uh, the elderly woman who I - who I know was the caller,  
937 um, she was screamin.' So I requested the fire department to, uh, provide a  
938 sheet so that out of respect for the gentleman and - and/or the folks that were  
939 starting to show up, um, I just felt that that was the proper thing to do.  
940  
941 Q: Okay. Do you remember who pronounced the subject?  
942  
943 A: The fire department.  
944  
945 Q: Um, do you remember if it was a captain or...?

946  
947 A: A captain.  
948  
949 Q: It was?  
950  
951 A: Yes.  
952  
953 Q: Okay.  
954  
955 Q1: I got a few more things to ask him.  
956  
957 Q: Do you have anything at all?  
958  
959 A1: Do you need a break or are you okay?  
960  
961 A: Hm-mm, I'm okay.  
962  
963 A1: Okay.  
964  
965 Q1: I'll get back to this. Go ahead.  
966  
967 Q: Okay. Uh, have you discussed the incident with anyone?  
968  
969 A: No.  
970  
971 Q: All right, have you written a supplemental report or anything...  
972  
973 A: No.  
974  
975 Q: ...related to the incident? Okay. Uh, I just want you to know, uh, this interview  
976 is - will act as your report.  
977  
978 A: Okay.  
979  
980 Q: So you don't - you don't need to write anything further.  
981  
982 A: Okay.  
983  
984 Q: Um, is there anything the suspect could have done to alter the outcome of the  
985 incident?  
986  
987 A: Absolutely. He could have listened to the directions. He could have put the  
988 machete down. Um, he could have stopped at any given time and not  
989 continued to, um, move forward in an aggressive manner.  
990



991 Q: Detective Kadelak?  
992  
993 Q1: Um, back to the question of did the officer or anyone deliberately accidentally  
994 alter the crime scene? You had a microphone, uh, your - what did you call it,  
995 our L3 mike?  
996  
997 A: Yes.  
998  
999 Q1: That was clipped onto your - where is that located on you?  
1000  
1001 A: I put it on my pocket over here.  
1002  
1003 Q1: Okay. Um, later on, uh, in the investigation, that was located inside your  
1004 patrol vehicle, is that correct?  
1005  
1006 A: Yes.  
1007  
1008 Q1: Okay. How did it get from your vest into the patrol vehicle?  
1009  
1010 A: When I was placed immediately in the back of the ambulance. And I don't  
1011 know how long the timeframe was, but eventually my lieutenant, um, showed  
1012 up and she removed it from my shirt and placed it in the patrol car.  
1013  
1014 Q1: And what is that lieutenant's name?  
1015  
1016 A: Uh, Lieutenant (Stephanie Foley).  
1017  
1018 Q1: Okay. And also the - um, you did say when you showed up there, all your  
1019 police lights were activated?  
1020  
1021 A: Yes.  
1022  
1023 Q1: Okay, did you noticed if the police lights on all the other vehicles, the police  
1024 cars were activated?  
1025  
1026 A: I didn't have the time.  
1027  
1028 Q1: Okay. Um, at any point did you shut your police lights off?  
1029  
1030 A: No.  
1031  
1032 Q1: Okay um, the reason I ask the question is because, uh, later in the  
1033 investigation when detectives had showed up, the police lights on three cars  
1034 were shut off. So I was just wondering if you shut them off or you know who -  
1035 who had shut them off.

1036

1037 A: I did not.

1038

1039 Q1: Okay. Um, I have nothing further.

1040

1041 Q: Uh, is there anything you, uh, you wish to address that we didn't discuss in the  
1042 interview?

1043

1044 A: No, I don't believe so.

1045

1046 Q: Okay, any questions that you have?

1047

1048 A: No, sir.

1049

1050 Q: Okay. The time is 1:31 pm, and we will be going off record.

1051

1052 A1: I'm off.

1053

1054

1055 The transcript has been reviewed with the audio recording submitted and it is an accurate  
1056 transcription.

1057 Signed \_\_\_\_\_ Detective Kevin Watt, #7345, April 23, 2020 at 1421 hours \_\_\_\_\_

1  
2  
3  
4  
5  
6  
7  
8  
9  
10  
11  
12  
13  
14  
15  
16  
17  
18  
19  
20  
21  
22  
23  
24  
25  
26  
27  
28  
29  
30  
31  
32  
33  
34  
35  
36  
37  
38  
39  
40  
41  
42  
43  
44  
45

**INTERVIEW WITH SGT. CASEY PELLETIER**

**Q=Det. Andy Reed**

**Q1=Det. Stephen Kadelak**

**A=Sgt. Casey Pelletier**

**A1=Chad Smith**

Q: Today's date is January 30th of 2020. The current time is 154 hours in the pm. Uh, my name is Detective Andy Reed -- R-E-E-D -- badge number 7325, with the Arizona Department of Public Safety Special Investigations Unit. Also with me is DPS SIU Detective?

Q1: Stephen Kadelak, badge number 6573.

Q: This is a, uh, voluntary criminal interview, uh, with Sergeant?

A: Casey Pelletier. First name C-A-S-E-Y, last P as in Paul E-L-L-E-T-I-E-R, and my badge number is 624.

Q: And he is with the Sedona Police Department. Uh, Sergeant Pelletier is represented by an attorney?

A1: Chad Smith -- S-M-I-T-H.

Q: Who is also present with us. Uh, this interview pertains to an officer-involved shooting that took place on Monday, January 20th of 2020 at approximately 1332 hours near 55 Newcastle Lane in Sedona, Arizona, involving Sedona police officers. The interview is taking place at the Ledbetter Law Firm. That's L-E-D-B-E-T-T-E-R, uh, located at 1003 North Main Street, in Cottonwood, Arizona. And the corresponding DPS department, uh, report number is Ida 20003903. Uh, Sergeant Pelletier, do you understand the interview is recorded and criminal in nature, however, completely voluntary?

A: Yes.

Q: Along with that, do you under- do you understand that you are free to leave to any time, and you are not compelled to answer any questions or you have the opportunity to discuss any of your questions and/or answers with your attorney in private as needed?

46  
47 A: Yes.  
48  
49 Q: I'll start with some, um, biographical information. Can I get your full name?  
50  
51 A: Yes, it's Casey David Pelletier.  
52  
53 Q: And what was your age at the time of the incident?  
54  
55 A: Thirty-one.  
56  
57 Q: And can you give a physical description of yourself?  
58  
59 A: Um, 6'2", 290. I'm not sure how much more - bald...  
60  
61 Q: Okay, that's fine.  
62  
63 A: ...with a black beard.  
64  
65 Q: Uh, do you wear contacts or glasses?  
66  
67 A: No.  
68  
69 Q: Are you right-handed, left-handed, or ambidextrous?  
70  
71 A: Right-handed.  
72  
73 Q: Okay. Um, what's your current occupation?  
74  
75 A: Police, uh, well sar- police sergeant for Sedona PD.  
76  
77 Q: Uh, is - do you know the address to the police station?  
78  
79 A: Yeah, 100 Roadrunner Drive, Sedona, Arizona 86336.  
80  
81 Q: And a cell phone number.  
82  
83 A: 928-282-3100. That's the main line unless you're wanting one for me directly.  
84  
85 Q: Nope. What's your date of employment with Sedona?  
86  
87 A: August 1, 2011. Also just for clarification on one of your other questions that  
88 matters, I did have Lasik surgery, so I used to have contacts and glasses, but I  
89 now have 20/20.  
90

91 Q: At the time of the incident.  
92  
93 A: Yeah.  
94  
95 Q: You had Lasik?  
96  
97 A: No - no, I've had it done years ago.  
98  
99 Q: Okay. Uh, your rank?  
100  
101 A: Sergeant.  
102  
103 Q: For patrol?  
104  
105 A: Patrol, yes.  
106  
107 Q: Uh, your badge number?  
108  
109 A: 624.  
110  
111 Q: Call sign?  
112  
113 A: Is Sam 1.  
114  
115 Q: When and where did you attend the police academy.  
116  
117 A: It was in No - The Norther Arizona Regional Training Academy. Then it was  
118 located in Prescott valley. And that was August of 2011 is when I had started.  
119 Finished December 2011.  
120  
121 Q: Have you received any specialized training?  
122  
123 A: Yeah, um, I have sific- specifically 160 hours' worth of collision  
124 reconstruction training. Um, I've attended um interview interrogation course.  
125 Um I'm trying to think of all my trainings now. Well I'm currently a driving  
126 instructor, general instructor, um, trying to think of all of em? Now I'm  
127 drawing a blank on others, so.  
128  
129 Q: Okay. What shift are you, uh, assigned to work?  
130  
131 A: Beginning of the weekdays.  
132  
133 Q: How long and what dates?  
134  
135 A: I work Sunday through Wednesday 9:00 am to 7:00 pm.

- 136
- 137 Q: And then what are your days off?
- 138
- 139 A: Uh, Thursday, Friday, Saturday. And it is different than the squad off - the
- 140 officers. They're still on 12s.
- 141
- 142 Q: Can you describe the uniform that you were wearing, um, from head to toe.
- 143 Uh, explain color of your pants, your shirt, your outer carrier, uh, any police
- 144 patches maybe on your shoulders or police placards that we would have front
- 145 and back.
- 146
- 147 A: Okay. I have dark navy, um, blue pants on. I had a long-sleeved shirt on, same
- 148 color. The outer carrier for my vest is the same color, as well, the dark navy
- 149 blue. Um, on the long-sleeved shirt I have on each shoulder the City of
- 150 Sedona patch as well as underneath that, the Sergeant insignia. Uh, the front
- 151 of my outer carrier, I have my metal Sedona police badge. On the back is a
- 152 placard. It's like a light gray with black lettering that says police. It is roughly
- 153 4 by 8 inches maybe, so maybe a little bigger, maybe 4 by 10, somethin' like
- 154 that. Um, on that as well, on the front of my vest there's regular shirt pou-
- 155 shirt pockets. There's a taser pouch rate - uh, radio pouch. Um, another pouch
- 156 on the side but nothing else super obvious.
- 157
- 158 Q: Okay. What type of duty belt and holster do you have?
- 159
- 160 A: I have a - what is it? I can't remember if it's Safariland or Bianchi. I think it's
- 161 the Bianchi. Um, it's like a pleather. I can't remember what material they call
- 162 it. Matte black duty belt. It's the large 2-inch one. And then I have a
- 163 Safariland - I can't remember what the name of it is. It's a - it's a molded
- 164 plastic holster that has, um, two levels of retention as the hood as well as the
- 165 additional release on it.
- 166
- 167 Q: So starting with your - your center clasp of your duty belt...
- 168
- 169 A: Mm-hm.
- 170
- 171 Q: ...moving in a clockwise, so to your right.
- 172
- 173 A: Okay.
- 174
- 175 Q: Describe all the pieces of equipment and as you're getting to them, explain
- 176 what side of your duty belt they're on.
- 177
- 178 A: Okay, and when you say clockwise, you mean my clockwise, correct?
- 179
- 180 Q: Correct, to your - to your right.

- 181  
182 A: All right, so from the clasp to the right of that, um, sideways is a hard-molded  
183 holster for a Soft T wide tourniquet, that I have a black tourniquet in. Um,  
184 that's on the front in front there. Then next to that as you continue clockwise  
185 is then the holster, my gun holster. Behind that would be - do you want  
186 keepers in there, too, actually? Because I have keepers between the, uh,  
187 tourniquet and the gun.  
188
- 189 Q: Just your equipment.  
190
- 191 A: Just equipment, okay. And then all the way around to then starting on the left  
192 side would be -- the back pouch would be my Safariland - or not s- yeah, it's  
193 Safariland, but it's a Streamlight stinger flashlight that I have there, and then  
194 in front of that is my OC spray, open top pouch. In front of that would be the  
195 double magazine. They're vertical but not - they're the same direction as my  
196 belt would be. They're not sticking out from it. And then in front of that  
197 would be a key hook, and after that would be a double handcuff pouch, which  
198 is then back at the very front of my v - um, belt.  
199
- 200 Q: And you said you were wearing an outer vest carrier?  
201
- 202 A: Yes.  
203
- 204 Q: Do you have any equipment on your outer vest carrier?  
205
- 206 A: Yes.  
207
- 208 Q: Describe that.  
209
- 210 A: Um, so from the - there's a center button line. So on the right-hand side of that  
211 is my Taser pouch which covers most of it except for the handle. Uh, it's a  
212 Velcro pouch at an angle, and then to the right of that continuing cau- uh,  
213 clockwise is a double handcuff pouch that I keep a set of handcuffs in as an  
214 extra set. And then I keep latex gloves in. And then going back to that center  
215 line and moving toward - counterclockwise, my left, is then my radio pouch,  
216 which there's a little small pocket off to the side of that, that has - that I have  
217 a, um, UV LED stylus and a handcuff key in.  
218
- 219 Q: Do you have any body cam?  
220
- 221 A: No body cam. But part of L3 that we have - The L3's the system we use. It's  
222 dashcams and then we have a remote, um, microphone box that actually sits in  
223 the center of my chest on that line, the buttons line.  
224
- 225 Q: And was that where it was sitting at the time of the incident?

226  
227 A: Yeah.  
228  
229 Q: Okay. Uh, moving onto your - your weapon, is it department issued or  
230 personal?  
231  
232 A: Department issued.  
233  
234 Q: And what's the make, model, and caliber?  
235  
236 A: Um, Glock, I always want to say it's 17 or I'm pretty sure it's 17, whichever  
237 one the full size one, 17 or 19. And caliber is 9 millimeter.  
238  
239 Q: Have you done any modifications to it, whether it's through an armor or...  
240  
241 A: Uh...  
242  
243 Q: ...trigger, sights, anything?  
244  
245 A: The only modification is adding a gun light to it.  
246  
247 Q: Is that a personal or department issue?  
248  
249 A: That's personal. Um, oh, and then actually they did add a - I think it's called a  
250 beaver tail grip to the top of it that prevents it from biting your hand with the  
251 slide.  
252  
253 Q: Okay.  
254  
255 A: But that was the department that did that.  
256  
257 Q: Eh, what type of ammunition?  
258  
259 A: Uh...  
260  
261 Q: Is it department issued ammunition?  
262  
263 A: Department.  
264  
265 Q: Did - does the magazines for your duty weapon, uh, 17-round capacity?  
266  
267 A: Yes.  
268  
269 Q: What do you load them up to?  
270



271 A: Sixteen each.  
272  
273 Q: And why do you do that?  
274  
275 A: Uh, it's to prevent, uh, damage to the spring and the magazine.  
276  
277 Q: Is that department wide...  
278  
279 A: Mm-hm.  
280  
281 Q: ...policy?  
282  
283 A: It's our standard, yeah.  
284  
285 Q: Okay. Uh, at the time of the incident, whether on you or in your vehicle that  
286 you had access to, what - do you have - do you carry around any other, um,  
287 use of force weapons, either shotgun, patrol rifle, beanbag rounds, um, baton,  
288 side handle baton, any other things that you carry in your car?  
289  
290 A: Yes, I have a asp, um, the baton for - that's in my patrol bag. It's the  
291 expandable one, um, as well as I have the AR15 in the center rack. It's a  
292 locked rack in the middle of the car. Um, time to time I'll have a backup  
293 weapon. I didn't that day, uh, which I would have on my ankle. As far as the  
294 beanbag less lethal shotguns that we have, it depends on staffing, because  
295 right now we have two per squad, so they get signed out each day. Um, I did  
296 not have one that day.  
297  
298 Q: So the only thing that you did have, you had your rifle, but that was locked...  
299  
300 A: Correct.  
301  
302 Q: ...away? Uh, and you did have the baton that was in the passenger seat?  
303  
304 A: Uh, yes, I have a patrol bag that hooks up. I loop it around the passenger seat  
305 headrest. And then on the outside of that which would be closer to the door,  
306 there's a large pouch that it sits in.  
307  
308 Q: Okay. Detective Kadelak anything?  
309  
310 Q1: Uh, talking about the - the alternate weapons that you had in your vehicle, did  
311 you utilize any of those, uh, weapons, your, uh, patrol rifle or - or anything  
312 else on that day...  
313  
314 A: No.  
315

316 Q1: ...other than your department-issued handgun?  
317  
318 A: Only the handgun.  
319  
320 Q1: Okay, and going back to the magazines that you loaded, you say you load  
321 them 16 and 16?  
322  
323 A: Sixteen and - all three have 16 in 'em, and then we do carry one in the  
324 chamber, so in a way that first one would be considered 17.  
325  
326 Q1: Okay.  
327  
328 A: But it's in the chamber.  
329  
330 Q1: One in the chamber, okay, just to clarify. Thank you.  
331  
332 Q: Uh, we'll move onto your vehicle. Can you, uh, describe your vehicle at the  
333 time of the incident, the color, make, model, and vehicle number?  
334  
335 A: Uh, it's a Black Ford, I think it's technically Interceptor. It's a police model,  
336 but it's an Explorer. Uh, it has Sedona decals on the sides of it and some on  
337 the back. Um, push bumper on the front. Spotlight on the driver's side over  
338 the top. Um, emergency lights, the red and blues are on the top, uh, for the  
339 outside. It's a - I'm pretty sure it's a 2014, and it's also vehicle number 14.  
340  
341 Q: Okay. So it was a fully marked police car?  
342  
343 A: Yes, fully marked.  
344  
345 Q: Did it have - having police labels on it?  
346  
347 A: Correct.  
348  
349 Q: Flashing red and blue lights on top...  
350  
351 A: Yes.  
352  
353 Q: ...of the exterior of the vehicle, uh, equipped with a siren?  
354  
355 A: Yes.  
356  
357 Q: Were all of those, uh, vehicle equipment functioning at the time?  
358  
359 A: Yes, I check it daily.  
360

361 Q: How we doin? Everybody good?  
362  
363 A: Yeah.  
364  
365 Q: So I'll, uh, I'll get into the - a few things prior to the incident. Uh, you logged  
366 on at 9 o'clock?  
367  
368 A: Yes.  
369  
370 Q: Did you conduct any traffic stops or respond to any calls for service?  
371  
372 A: I think there were some calls for service. I can't remember details of any of  
373 'em to be honest, so.  
374  
375 Q: Did you - did you respond and - and interact with citizens or whoever might  
376 have called or, um, the - the general public?  
377  
378 A: Yes, uh, for those calls I would have, yes.  
379  
380 Q: Did they recognize you as a police officer?  
381  
382 A: Yes.  
383  
384 Q: Okay. Um, for that day on the 20th, did you have a civilian observer, uh,  
385 another officer, or a canine riding with you?  
386  
387 A: No.  
388  
389 Q: Um, where were you at in the city when the - you - the initial call for service  
390 happened?  
391  
392 A: Actually in the breakroom. I had just started lunch.  
393  
394 Q: So you were at the Sedona...  
395  
396 A: At the se- at Sedona Police Department.  
397  
398 Q: Okay. Um, how did you receive the information?  
399  
400 A: Over the radio.  
401  
402 Q: Uh, what information did you hear over the radio?  
403  
404 A: Uh, initially was a hot tone, which is our emergency tone for what would be  
405 deemed a more emergency type call to respond to. Then afterwards we got

406 told the location, uh, the 55 Newcastle Lane, saying that there was - uh, the  
407 caller was inside a building, and there was someone outside with a hatchet  
408 tryin' to get in.  
409  
410 Q: Okay. At that time what did - what did you do?  
411  
412 A: Got up, left everything there, and went to my vehicle, and began driving code  
413 3, which is lights and sirens, to the scene.  
414  
415 Q: Okay. While you were in route to the call or to the location of the call, did you  
416 receive any further information?  
417  
418 A: I don't remember.  
419  
420 Q: Okay. But you - the information you had received was serious enough that  
421 you felt lights and siren was appropriate. You needed to respond, um, quick -  
422 more quickly than you normally would on any lower priority call?  
423  
424 A: Absolutely. Someone trying to get into an area with another person with a  
425 edged weapon, uh, that leads to very easy means for someone to get injured.  
426  
427 Q: Do you remember if they gave a sus- a suspect description from the call?  
428  
429 A: Uh, yes. I don't remember what exactly they said for the description, though.  
430  
431 Q: Okay. Did you know who was responding to the call with you?  
432  
433 A: Yes.  
434  
435 Q: And who was that?  
436  
437 A: Uh, Officer Hudspeth and Officer Hunt.  
438  
439 Q: Okay. Um, so as you get - as you get to the scene, you arrived to where the  
440 call was at, uh, I just want you to walk me through or describe just the scene  
441 of the call.  
442  
443 A: Okay. Um, so we were in single file, Officer Hunt in front, I'm pretty sure,  
444 and Officer Hudspeth second car, and I was third car. A very narrow area, you  
445 go down a concrete - I don't wanna say bridge. It's like a water crossing for,  
446 um, a wash there - and then up. And it opens up to where there's houses on  
447 the right side, a few small houses. On the left is what used to be an apartment  
448 building, but now is being constructed into an air BNB area but still the same  
449 construction. And then in the middle it's rather open, a few trees. Uh, behind  
450 that is - I'm pretty sure it's the creek right there, uh, and then another hill

451 behind it. Um, as we pulled up, Officer Hunt was the lead car. Stopped  
452 directly in front of, um, the person at, um, sitting I guess yoga style on - uh,  
453 like cross-legged - cross leg, that's the term I'm looking for - um, on the  
454 retaining wall facing us. Um, he called out that he had found the person we  
455 were being called for. Officer Hudspeth went to the right. I turned around to  
456 the left, um, of Officer Hunt's car and then got out of my car.

457

458 Q: As you arrived, do you remember - do you have your police lights activated?

459

460 A: Yes, I'd turned off my siren as I got closer, um, as I got close, but I did have  
461 the lights on.

462

463 Q: Front and back?

464

465 A: Yes.

466

467 Q: Do you remember the other two vehicles in front of you having 'em?

468

469 A: No, I don't remember if we did at the scene or not or if they had turned 'em  
470 off.

471

472 Q: Okay. Do you...

473

474 A: Up to the scene, yes, but I don't remember if on the scene if they had turned  
475 'em off or not.

476

477 Q: Okay. Do you remember the lighting conditions?

478

479 A: It was daylight, a pretty clear day. I don't think there as much in the way of  
480 cloud cover. I remember it being pretty bright, so.

481

482 Q: Okay. When you arrived - Detective Kadelak, do you have anything?

483

484 Q1: Um, I'll just add a question or two. When you arrived in that area, is that - uh,  
485 was there a volume of vehicle traffic in that area?

486

487 A: No, there was not - I mean specifically on that road, no. Um, there wu- I think  
488 there was a couple cars we passed on the other road leading up to it, but  
489 nothin' in that specific area.

490

491 Q1: So would you describe it as a secluded or remote type area?

492

493 A: Oh, absolutely. It's an area that I've very rarely been to.

494

495 Q1: Volume of pedestrian traffic? There's no sidewalks or people walking in that

496 area?  
497  
498 A: Uh, there's no sidewalks and actually I didn't see anybody when we came in. I  
499 don't remember seeing any pedestrians, uh, out in that area there.  
500  
501 Q1: Okay, and, uh...  
502  
503 A: (Unintelligible) my uniform hat? I forgot about that.  
504  
505 A1: What?  
506  
507 A: My uniform hat, so I can clarify that, too.  
508  
509 Q1: Will you.  
510  
511 Q: Mm-Mm. I'll get to that  
512  
513 Q1: Was there something you want to clarify about your uniform?  
514  
515 A: Oh, yeah. I just remembered, um, for my uniform, as well, I wear a dark navy  
516 blue ballcap that on the front in gold lettering says Sedona Police. I was  
517 wearing my sunglasses at that time, so it wouldn't have been impeded by the  
518 sunglasses.  
519  
520 Q1: Okay, thank you.  
521  
522 Q: So as you arrive on scene, you are the third one in the line? From what I  
523 understand, Officer Hunt was the middle car. Officer Hudspeth goes to the  
524 right and you go to the left.  
525  
526 A: Correct.  
527  
528 Q: As you fan out, what do you observe?  
529  
530 A: Uh, right away I see Officer Hunt get out of the car, um, draw his pistol, and  
531 that's when I saw the gentleman sitting on the retaining wall in the cross-  
532 legged stance or cross-legged position.  
533  
534 Q: Did - did you immediately recognize or just kinda cue off of, uh, Officer  
535 Hunt's reaction that this is the guy that you were looking for?  
536  
537 A: Uh, it was very clear that this was the guy that matched the description at that  
538 point with the way he was acting. Um, I didn't initially see the blade that - the  
539 longer blade that he had. It was sittin' across his legs. Um, my angle, I didn't  
540 see it right away, but I heard Officer Hunt right off the bat begin commands

541 for drop the knife.

542  
543 Q: When - when you finally got into clear view of the subject, did you recognize  
544 him at all?

545  
546 A: No, I did not.

547  
548 Q: All right. Um, so as you see Officer Hunt, um, draw his handgun, what do you  
549 see the subject do?

550  
551 A: Um, he was acting unaware of where - that we were there. Um, then Officer  
552 Hunt began commands of drop the knife. Then he seemed to realize we were  
553 there, grabbed something in his lap. That's when I realized that he had a  
554 substantial blade, and I drew my weapon. Um, and I remember him saying,  
555 "What are you gonna do, shoot me?" And then he stood up from the wall with  
556 his hands on the - I don't know if you'd call it a sword or a machete, a small  
557 sword, large machete, and began walking toward us at that point. And, um, I  
558 know myself and Officer Hunt for sure were calling. He said, "Drop the  
559 knife" at one point. I said, "Drop the sword," um, because that's definitely  
560 what it looked like for me at that point.

561  
562 Q: How - how long do you think the blade was of the sword?

563  
564 A: Uh, I'd say all in all with the handle it'd be about I'd probably say close to 2-  
565 1/2 maybe 3 feet at the most.

566  
567 Q: And, uh, rough estimate of where you're standing at in comparison to the  
568 subject.

569  
570 A: Um, 25 - 20, 25 feet. He was on that retaining wall, and we were, um, up by  
571 the front of Officer Hunt's vehicle.

572  
573 Q: So as Officer Hunt and yourself are giving verbal commands, what are you  
574 specifically saying?

575  
576 A: Um, I did both. I said, "Drop the sword and drop the knife."

577  
578 Q: And did he comply?

579  
580 A: Absolutely not.

581  
582 Q: What was the subject's actions to follow?

583  
584 A: Um, he then stood up with the knie- with the blade in his hands and began  
585 directly going towards, um, myself and Officer Hunt, more specifically

586 towards Officer Hunt with the blade in front of him, what I would consider  
587 ready to use.  
588

589 Q: And you're giving me, uh, a visual description. Can you explain it, was it two  
590 hands on the handle of the sword? Was it down by his sand? Was it in one  
591 hand?  
592

593 A: Uh, two - um, two hands on it with the sword in front of him, um, arms bent to  
594 where his hands would be roughly even with his chest, um, coming towards us  
595 like ready to be able to swing at that point.  
596

597 Q: Was that the only weapon that you observed on him?  
598

599 A: Absolutely. I saw that and then focused on his ability to be able to use that.  
600

601 Q: And then based on your commands that you were giving, him failing to follow  
602 it, on a scale of 1 to 10, 1 being not aggressive at all and 10 being very  
603 aggressive, what would you rate the subject as?  
604

605 A: Nine to 10. I mean he wasn't at a sprint, but he definitely had a very clear path  
606 going towards us with that weapon.  
607

608 Q: So he is now approaching you or Officer Hunt or both?  
609

610 A: Both, but more specifically he seemed more focused on officer Hunt.  
611

612 Q: And what type of pace is he?  
613

614 A: Um, I'd say a quick walk at that point.  
615

616 Q: Okay. Do you remember what he was wearing or a physical description? Kind  
617 of explaining his size or...  
618

619 A: Mm, uh, um, I'd say he's definitely a bigger gentleman. He's probably - I  
620 mean he seemed stockier and he had shorts on and I wanna say like a vest  
621 overhang over his shirt. I don't remember if it - yeah, like a T-shirt and shorts.  
622 Um, I'm pretty sure he had sunglasses on. Um, but he wasn't a small person  
623 by any means. He was good size.  
624

625 Q: So in correlation to we'll say your patrol vehicle and then Officer Hunt's  
626 patrol vehicle, where are standing at as you're seeing the suspect or the  
627 subject approach?  
628

629 A: Uh, to the left or the - a little bit aways on the driver hand side probably, I  
630 don't know, five, six feet maybe away from the car on the driver's side up



631 front.

632

633 Q: Whose vehicle?

634

635 A: Of Officer Hunt's.

636

637 Q: Okay. And you were still 25 to 30 feet?

638

639 A: Um, well he closed that distance. That's when it started.

640

641 Q: Okay.

642

643 A: I didn't move.

644

645 Q: Do you remember outside of, uh, I think you reference something of him

646 saying, "What are you gonna do, shoot me?" Outside of that, was there

647 anything that he - that he yelled out or said to any of the officers on scene?

648

649 A: I don't remember anything else being said by him, just our commands and

650 him not complying.

651

652 Q: Okay. Describe the subject's actions as he starts that - that steady pace

653 towards Officer Hunt. Explain what happens next.

654

655 A: Um, again, he seemed pretty focused on him. Um, seemed more of a direction

656 towards Officer Hunt. We continued giving commands. I don't know how

657 many times we said to drop it. He didn't. Um, once he got roughly 10 to 12

658 feet away, um, I'm not sure who did first, but myself and Officer Hunt both

659 fired. Um, I was definitely terrified at that point of what he would be doin' to

660 myself or Officer Hunt with that blade. And I wasn't okay with him gettin'

661 any closer.

662

663 Q: How many rounds did you fire?

664

665 A: Um, I wanna say three to four from what I remember. I know the round count

666 was four. Initially I know I shot two and slowed down to evaluate to make

667 sure if that was stopping or not. Um, after the first two, um, the gentleman we

668 shot, he turned about. He was grunting, that kind of thing at that point, like he

669 was in pain. Still had the blade in the same position but turned away from us.

670 Um, and then he started turning back around to continue moving towards us,

671 and that's when I fired again.

672

673 Q: And how many times did you fire the second time?

674

675 A: I would think two, because of the round count, but I know it would be three or

676 four. I remember specifically three.  
677

678 Q: Do you - explain why you - uh, explain again why you fired two rounds and  
679 then paused for a second.  
680

681 A: Okay. So I fired two rounds initially, because the level of threat he was  
682 bringing, um, dictated that I needed to stop that threat, and so I fired two  
683 rounds, stopped for a moment to assess whether or not he was continuing his  
684 progression of potential attack, and that's when he then turned around. That's  
685 why I stopped to evaluate to see, is he gonna continue with this or is he  
686 stopping?  
687

688 Q: What did you think the subject was going to do with that sword or blade  
689 object?  
690

691 A: Absolutely he was gonna swing it at one of us.  
692

693 Q: And what - what would have been the repercussion in your - in your...  
694

695 A: Massive damage. That's - it's a sword. Um, it's massive laceration, significant  
696 injuries. I mean that leads to - I mean an artery could easily be hit, anything  
697 else be hit. I mean very easily could have killed one of us or both of us with  
698 that, especially at that range if I let him get even closer, if he then split the two  
699 of us and then I did have a safe angle to be shooting, uh, to stop the threat,  
700 because Officer Hunt's in my way. Um, so all of that.  
701

702 Q: Through your training and experience, somebody with a blade object like that,  
703 what do you view that type of weapon as?  
704

705 A: Oh, it's absolutely lethal. It's a very easy weapon. It takes zero training to use.  
706 Never jams. It's - you can puncture someone with it. You can swing it at  
707 someone to cut 'em. It's a very versatile weapon with zero training.  
708

709 Q: Do - did you - you utilize your tactical light on your handgun?  
710

711 A: I did not.  
712

713 Q: Do you remember what your sight picture was?  
714

715 A: It was - uh, yeah, it was front sight on his chest area.  
716

717 Q: On his chest area?  
718

719 A: Mm-hm.  
720

721 Q: Middle chest?  
722  
723 A: Middle chest.  
724  
725 Q: Do you remember the backdrop behind the subject?  
726  
727 A: Yes, I do.  
728  
729 Q: What was that?  
730  
731 A: Uh, mostly an undeveloped hill. There was a spot that had a small like open  
732 patio grass area type area that had some lawn chairs up there. But, um, that  
733 was off to the side. My - from what I remember, my view was with a  
734 undeveloped hill behind, us, behind him.  
735  
736 Q: So you said initially you shot twice, and he was turning around kind of  
737 stumbled but still standing up?  
738  
739 A: Yes.  
740  
741 Q: Still continued to have the weapon in his hand?  
742  
743 A: Yes.  
744  
745 Q: Was it down by his side, over his head? Do you remember?  
746  
747 A: Still in the same position as I described the first time. He still had it up against  
748 him. It almost seemed like he was holding it to like from pain to control, like  
749 to hold it against him almost, like that kind of thing.  
750  
751 Q: And then following, you reengaging and firing the other - the other sequential  
752 shots, did - what happened to the suspect at that point?  
753  
754 A: Um, at that point he turned away again and fell to the ground, um, face down.  
755 Then we continued giving commands, telling him to drop the knife, get rid of  
756 the knife, put it away, like get it away from him, um, to trying to maintain the  
757 safety of, um, his potential attack if we can - when we come close to handcuff  
758 him at that point. Um, after a few moments, it seemed pretty clear that he was  
759 not gonna be responsive, and so then we began planning how to safely  
760 handcuff him.  
761  
762 Q: Did you ever feel that your life was in danger?  
763  
764 A: Absolutely.  
765

766 Q: Uh, what was your intent when you fired your weapon?  
767

768 A: To absolutely stop him from attacking myself, Officer Hunt, anyone else that  
769 might have been in the area that I wasn't focused on at the time.  
770

771 Q: Okay. Detective Kadelak, do you have anything?  
772

773 Q1: Um, after you fired your, uh, your department-issued handgun, did you do a  
774 tactical, uh, exchange or reload or anything like that...  
775

776 A: No.  
777

778 Q1: ...that you recall? Okay.  
779

780 A: I did not.  
781

782 Q1: That's all.  
783

784 Q: So you reholster your weapon or do you take a different stance following, uh,  
785 the suspect now laying on the ground, eh, face down? Did you reload? Did  
786 you relocate? Did you take a cover of - of...  
787

788 A: Uh, I think I took a few steps to the left two or three. And then after the  
789 commands with seeing that he wasn't gonna be responsive continuing, um,  
790 and it seemed like he probably wasn't able to respond at that point, that's  
791 when we then spoke of how to go about doing that. I had Officer Hudspeth  
792 move over to straight in line with him, and Officer Hunt and I would come  
793 from the side. So there was a clear path if, you know, he was faking it or  
794 something to where once we got close he decided to try and attack one of us.  
795

796 Q: Okay. Did you - did you ever have an opportunity to use any less lethal force?  
797

798 A: Um, I could have drawn out initially, I guess, but I don't think it was  
799 reasonable for how quickly everything progressed.  
800

801 Q: Based on your training, if somebody's presenting you with, uh, a deadly  
802 weapon, what is your response to that?  
803

804 A: Um, to stop that threat with the force reasonable and necessary at this point.  
805 Absolutely reasonable and necessary to use the lethal force of the handgun to  
806 stop that, 'cause taser fails are somethin' like that, he's gonna be able to close  
807 that distance and do substantial damage to myself or someone else.  
808

809 Q: So after the- after the suspect's laying down, uh, did anybody radio for fire or  
810 medical?

- 811
- 812 A: Someone did. I don't remember exactly who did. We radioed right away once
- 813 we got him handcuffed.
- 814
- 815 Q: Did you - did you or anybody else render aid?
- 816
- 817 A: Uh, no.
- 818
- 819 Q: Pertaining to the scene, you had fire personnel, medical personnel coming into
- 820 the scene. Do you happen to remember who pronounced the susp- the subject
- 821 dead?
- 822
- 823 A: No, I was not there when that was happening. I was then -- at that point I had
- 824 grabbed a, um, roll of evidence tape to block everybody off from the area.
- 825
- 826 Q: And what's the purpose for doing that?
- 827
- 828 A: To secure the integrity of the scene and all the evidence as well as, um, not
- 829 having a populous in the middle of it that could then become upset or
- 830 something else. That'll protect everybody, as well.
- 831
- 832 Q: Okay. Did you or anyone else accidentally or deliberately alter the crime
- 833 scene?
- 834
- 835 A: Yes. We removed the weapons. Um, initially we - actually I think Officer
- 836 Hunt might have kicked the large blade away. Um, we found a hatchet on his
- 837 side in a holster, like a shoulder mount like would be somewhere for a
- 838 handgun. And then as we rolled him over to make sure there was nothing else,
- 839 we found - we saw immediately a knife, um, parallel to like a belt on the front
- 840 of his, um, waistband. Um, started trying to remove that, and that's when I
- 841 stepped away to then start doing all that with the crime scene tape and
- 842 everything.
- 843
- 844 Q: So what happened with...
- 845
- 846 A: Uh, they wound up removing it, and then Officer Hudspeth - um, I didn't see
- 847 exactly the whole progression of it, but I saw him at one point having them on
- 848 a sheet from I would assume - excuse me - the fire department, because we
- 849 don't carry those. Um, he put those weapons there and then, um...
- 850
- 851 Q: Who was that again?
- 852
- 853 A: Officer Hudspeth.
- 854
- 855 Q: Okay.

856  
857 A: And put 'em into the back of his car. Uh, between there, one of the guys said  
858 he didn't have latex gloves, um, so I went back to my car grabbed a box of  
859 gloves, and I tossed 'em up to him behind him a little bit, so that way they had  
860 'em for whatever was needed, and I left mine there. I don't - yeah, I left those  
861 there.  
862  
863 Q: And did you remain into the scene while command staff, fire, and...  
864  
865 A: Yes.  
866  
867 Q: ...other agencies responded?  
868  
869 A: Yes.  
870  
871 Q: Wu- did you receive any directive, uh, from any of your chain of command to,  
872 uh, remove any equipment on your - your duty belt, your - your uniform, or  
873 your patrol vehicle?  
874  
875 A: Yes, later on. I had it on me, um, up until I think it was - yeah, it was once  
876 Lieutenant Foley got there. Um, she directed me to then take that body mike  
877 off, and I put it inside my patrol car.  
878  
879 Q: And was your patrol vehicle lights still activated during the incident?  
880  
881 A: Uh, yeah, I'm pretty sure. Yeah.  
882  
883 Q: Do you remember who shut the lights off?  
884  
885 A: No.  
886  
887 Q: Okay. Have you discussed this incident with anyone?  
888  
889 A: Um, just my, um, therapist.  
890  
891 Q: And did you write a supplemental report?  
892  
893 A: No.  
894  
895 Q: Okay, just as a reminder, this interview, um, will take place of your report.  
896 Uh, you won't need to write anything...  
897  
898 A: Okay.  
899  
900 Q: ...um, related to this incident. Um, is there or was there anything that the

901 suspect could have done to change the outcome of this incident?  
902  
903 A: Absolutely.  
904  
905 Q: What is that?  
906  
907 A: One hundred percent he could have complied. He could have dropped that  
908 knife right off the bat more than a substantial distance and we'd a been able to  
909 handle this so much better with him to where this would not have been the  
910 result. If he'd just complied with getting rid of those weapons like we told  
911 him.  
912  
913 Q: Detective Kadelak, do you have anything?  
914  
915 A: I do realize one of your last questions, I did actually speak with my attorney,  
916 as well, about what happened. So I just want to make sure for that question I  
917 got it all.  
918  
919 Q: Sure, thank you.  
920  
921 Q1: Um, just for the record, prior to the interview that we had, you have not, uh,  
922 listened to any audio or - or viewed any dash cam footage prior to the  
923 interview?  
924  
925 A: I have not.  
926  
927 Q1: Okay. Uh, I have nothing else.  
928  
929 Q: Uh, is there anything you wish to address that we didn't discuss or cover in  
930 the interview?  
931  
932 A: Not that I can think of. I think that covers it.  
933  
934 Q: Do you have any questions?  
935  
936 A: No.  
937  
938 A1: Objection, yes?  
939  
940 A1: Um, just one, and I think we've kinda been through it. So you said, um, the  
941 moment you took the shot, you were in fear for your life, the life of the other  
942 officers around you. Um, is it true that he was also trying to break into an  
943 apartment?  
944  
945 A: Yes, that's what we got initially. He was trying to get into that apartment.

946  
947 A1: And so by you taking that shot, were you also protecting the public?  
948  
949 A: Yes.  
950  
951 A1: So you believe that potentially if he had used the weapon on you, on the other  
952 officers, he could've then used it on the public?  
953  
954 A: Absolutely.  
955  
956 A1: So you were in fear for the life of the public, as well?  
957  
958 A: Yes.  
959  
960 A1: I have nothing further.  
961  
962 Q: Okay. The time is 2:34 pm. We will be going off record.  
963  
964  
965 The transcript has been reviewed with the audio recording submitted and it is an accurate  
966 transcription.  
967 Signed \_\_\_\_\_ Detective Kevin Watt, #7345, April 23, 2020, at 1717 hours \_\_\_\_\_





**ARIZONA DEPARTMENT OF PUBLIC SAFETY**  
**INTERVIEW SUMMARY**

<b>DR NUMBER:</b>	<b>I20003903</b>
-------------------	------------------

Person Interviewed: Cheryle Harrell

Residence:

Business Address:

Telephone:



**Interview summary**

On Monday, January 20, 2020, at 1753 hours, Arizona Department of Public Safety (DPS), Special Investigations Unit (SIU), Detectives John D. Ruble, #5627, and Kenneth Ellis, #6659, interviewed Cheryle Harrell. The interview was conducted at [REDACTED] The audio recorded interview commenced at 1755 hours and concluded at 1822 hours. The audio recording, evidence item JDR1, was submitted into the DPS Central Regional Property and Evidence (CRPE) Section located at 2323 North 22<sup>nd</sup> Avenue, Phoenix, Arizona for storage.

The interview pertained to Cheryle Harrell’s involvement in an Officer-Involved shooting investigation, which occurred at 55 Newcastle Lane, Sedona, Arizona.

In summary Harrell recalled the following information:

Harrell said earlier in the day she was cleaning one of her rental properties, which is located at 55 Newcastle Lane. Harrell said she was working on unit #17 when she saw an unknown male walk onto the property. Harrell said she approached the male who had his back towards her, and his arm extended towards the sky with a large stick in his hand, chanting, and yelling. Harrell said the male turned around and as he did, she saw a machete in his hand which he held down to his side. Harrell said she did not recall which hand the stick or machete was in.

Harrell said as the male turned around, he was staring at her, but it was “like he did not see me.” Harrell said his eyes were strange, cold, and it was like he looked right through her. Harrell told the male he was on private property and he would have to leave. Harrell said the male raised both the large stick and the machete above his head and continued to chant. Harrell said fearing for her life, she immediately turned and ran towards unit #17. Harrell said as she ran, she heard the male tell his dog, a pit bull, to “get her.” Harrell said the male chased her, she did not look back, but she could hear sounds of footsteps behind her.

Harrell said upon entering unit #17, she locked the deadbolt of the door and ran into a bedroom at the back of the unit fearing the male would break through the front door. Harrell immediately called 911 emergency operator to report the incident and she requested the police to respond.

Harrell said she had a visual on the male as she spoke with the 911 emergency operator. Harrell advised the operator the male had climbed on a retaining wall on the property. Harrell told the 911 emergency operator to have the police hurry as the male had opened his vest and it appeared, he was pulling the machete across his bare chest. Harrell said the male was chanting and it

Detective Name	ID No.	Location	Date	Supervisor
John D. Ruble	5627	31030200	02/11/2020	Sergeant Jeromy McDonald, #6513



**ARIZONA DEPARTMENT OF PUBLIC SAFETY**  
**INTERVIEW SUMMARY**

<b>DR NUMBER:</b>	<b>I20003903</b>
-------------------	------------------

appeared to her he was performing some type of ritual.

Harrell said the 911 emergency operator told her the police were on property and disconnected from the call. Harrell walked out on to the porch of unit #17 as three Sedona Police Department vehicles arrived on the property. Harrell said she recalled all the Sedona Police Department vehicles had emergency lights activated, and she could hear an emergency siren. Harrell said she could not tell if the emergency siren was from one of the Sedona Police Department marked patrol units or an ambulance.

Harrell said the responding police units were clearly identifiable as Sedona Police Department. The police vehicles were marked with Sedona Police Department on the vehicles and the officers wore police uniforms, which identified them as Sedona Police officers.

Harrell said from her location on the front porch of unit #17 she had a clear view of the male and the Sedona Police officers. Harrell said when the first Sedona Police Department vehicle stopped, a uniformed officer exited with his gun drawn, as did the two additional responding police officers. Harrell said the male was standing on a four-foot retaining wall when the police arrived.

Harrell said she heard three or four clear commands given by the Sedona Police officers ordering the male to get down off the wall. Harrell said as the male moved from the wall and onto the ground, he had the machete and large stick in his hands raised above his head. Harrell said the male was approximately 20 feet from the officers.

Harrell said the Sedona Police officers told the male, "Put the weapons down, put the weapons down, put the weapons down, and he just wouldn't, he just wouldn't, I have never seen anything like it, he just wouldn't." Harrell said the male continued to raise his arms up in the air holding onto the stick and machete.

Harrell said the male began to walk towards the officers, "like an attitude to it, like a swagger, slow, not running towards the officers, but moving towards the officers." Harrell said the male then opened his vest and said, "shoot me, go ahead and shoot me, are you going to shoot me." Harrell said the police did fire their weapons at the male.

Harrell described the male as muscular with a mohawk style haircut wearing a black/brown vest and camo-style pants. Harrell said the male was "chanting" and it appeared he was doing a "Native American dance."

Harrell said if the male had listened to the Sedona Police officers' commands and dropped the machete, the outcome of the encounter would have been different, he would be in jail.

Detective Name	ID No.	Location	Date	Supervisor
John D. Ruble	5627	31030200	02/11/2020	Sergeant Jeromy McDonald, #6513

**INTERVIEW WITH CHERYLE LYNNE HARRELL**

**Q=Det. John D. Ruble**

**Q1=Det. Kenneth Ellis**

**A=Cheryle Harrell**

**A1=Erick**

1  
2  
3  
4  
5  
6  
7  
8  
9  
10  
11  
12  
13  
14 Q: This is Detective John Ruble, Department of Public Safety assigned to the  
15 Special Investigations Unit. We are at [REDACTED] investigating an  
16 officer involved shooting. Present with me today is Detective Kenneth Ellis  
17 with DPS. For the tape could I get you to give me your full name and your  
18 badge, sir?

19  
20 Q1: Uh, Kenneth Ellis, the last name spelling E-L-L-I-S. Badge number 6659.

21  
22 Q: The person being interviewed today is Cheryle Harrell of, um, Sedona,  
23 Arizona. For the tape could I get you to give me your full name and spell your  
24 last name, please?

25  
26 A: Cheryle Lynne Har - Harrell -- H-A-R-R-E-L-L.

27  
28 Q: Okay, ma'am I want to take you back today, earlier today when you were, um,  
29 cleaning a house at about fif- on 55 Newcastle Lane in Sedona.

30  
31 A: Mm-hm.

32  
33 Q: Could you go through the chain of events, um, at that time that you were  
34 cleaning that house and what drew your attention to someone out in the yard  
35 yelling?

36  
37 A: Sure. This afternoon I was cleaning our Airbnb and I was in unit 17, which is  
38 downstairs next to the creek and I noticed a gentleman walking onto the  
39 property.

40  
41 Q1: Can you pause it for one second? Were you in 55 or were you in one of the  
42 Airbnb's?

43  
44 A: I was in 17.  
45

46 Q1: Okay.

47

48 A: So anyway, I noticed a gentleman, um, walking onto the property. We have  
49 six or seven big garbage cans on the property and that's how I noticed him,  
50 um, I just happened to look over at the garbage cans. I did not see at first that  
51 he - all's I saw was a walking stick, I didn't see the machete at first. He  
52 walked over got up on our retaining wall, that's when I saw the machete and I  
53 walked up to him and I - you know, can I start over I just messed that up. I did  
54 - I did.

55

56 Q: Yes - yes ma'am if you wish to start, go right ahead.

57

58 A: Okay.

59

60 Q: The time right now is gonna be 1755 hours.

61

62 A: Okay thanks. When I saw him by the garbage cans I walked out to him - that's  
63 when I walked out to him and I said, "Excuse me, can I help you?" and he  
64 kind of looked right through me and I said, "Excuse me?" and I said again,  
65 "You - you have to leave; you're on private property." And again, he looked  
66 right through me. That's when he turned and that's when I saw the machete  
67 come out. I don't know if it was in his pants, I don't know where it was.  
68 'Cause when I first saw him, I actually didn't see it. He then took the machete  
69 and the - the walking stick put it up over his head turned around a few times  
70 just yelling and screaming, uh, I don't know what 'cause it didn't make any  
71 sense. That's when I really got scared and I started to - I turned around to go  
72 into the house and I heard him say, "Get her." Because he had a pit bull with  
73 him, with three legs. And then he started to chase me, I got into the house, I  
74 locked the door. He just turned right back around and headed right to the  
75 retaining wall. And then when he got onto the retaining wall again, he took the  
76 machete and the stick and was just whirling it around in the air and kept  
77 chanting and chanting. I don't know what. I was on the phone at this point in  
78 time in the bedroom with 911. And I do remember asking her to please get the  
79 police here very quickly 'cause at that point he had sat down on the retaining  
80 wall. Opened up his vest and he didn't have a shirt on, and he started to take  
81 the machete across his chest. But - it didn't look like he really cut himself at  
82 that point, and the - right then the 911 operator said the police are on the  
83 property. I went out to the porch when the police arrived, he was the - the guy  
84 was up on the retaining wall still at that point with the machete up in the air  
85 and the walking stick up in the air. The police were yelling for him to get off  
86 the wall and that took several seconds or so and then he finally got off the wall  
87 and the police were yelling at him to put the weapons down - put the weapons  
88 down- put the weapons down. And he just wouldn't - he just wouldn't. I've  
89 just never seen anything like it. He just wouldn't and then he - he was still  
90 going up in the air with all that stuff that he had in his hands and then he

91 opened up his vest and he said, "Shoot me, go ahead and shoot me. Are you  
92 gonna shoot me?" And they did, and that was that. I've never seen anybody  
93 get shot in my life. Sorry. That was it, he's gone.  
94

95 Q: Do you need a few more minutes?  
96

97 A: I'd rather just get it done. I'm tired.  
98

99 Q: Okay - okay Cheryle I'm gonna have a few follow-up questions. I know  
100 Detective Ellis was - for the tape let me put on the incident number. I'll make  
101 sure you have it with my business card. It's gonna be I20003903 that'll be the  
102 incident number. I will leave you a business card. You said - if I could take  
103 you back please. You were in unit 17 next to the creek, so in that area as you  
104 drive over the creek you're going east, is that correct over the creek and that  
105 unit 17 would that have been to the left?  
106

107 A: It's to the left.  
108

109 Q: Okay. So that unit's next to the creek it's number 17. You said you saw a  
110 male. What direction did he come from, in relationship to unit 17 where you  
111 were?  
112

113 A: He came from the - from our driveway I mean he came in on the pro - there's  
114 only one way onto the property and that's up through that driveway. An- but I  
115 didn't see him until he reached the garbage cans.  
116

117 Q: Okay and they're fairly close then to unit number 17?  
118

119 A: No.  
120

121 Q: Where are they located at?  
122

123 A: They are - the building - the building sits out by Oak Creek and I - I don't  
124 know if it's north, south, east or west. I...  
125

126 Q: Okay.  
127

128 A: I stink at directions. 'Kay and the garbage cans are at the farthest end of the  
129 property at the - at the, uh, the other side of the property over by the driveway.  
130

131 Q: Which would be on the south side?  
132

133 A: Correct.  
134

135 Q: At the driveway, okay - okay. What did the male look like? Could you

136 describe him to me, please?  
137  
138 A: He had kind of a Mohawk. And then he was totally bald except for a patch of  
139 hair right in here.  
140  
141 Q: Right in...  
142  
143 A: Right on the top of his head, sorry. Right on the top of his head. He had some  
144 kind of a vest on, I'm not sure what color it was I - I'm gonna be honest with  
145 you it was either like a black or a brown or something. But it was something it  
146 wasn't, like, a light color okay? When he turned around on his vest, I saw that  
147 there was some writing on it, but I couldn't read it, and then his pants were,  
148 like, to me they kind of looked like a little bit of camouflage cargo pants. But  
149 the thing that I noticed about the vest and stuff when he turned around and  
150 looked at me and here's the really weird part, I can't remember what his face  
151 looks like. At all.  
152  
153 Q: 'Kay.  
154  
155 A: But when he turned around and looked at me, I did notice 'cause he - he was  
156 muscular but I noticed, like, his vest was really sticking out. If, you know,  
157 like, sticking out w- kind of far away from his body. As were his pants and  
158 then he had - I'm not sure what kind of boots they were. I don't know if they  
159 were hiking boots I really - I really don't know.  
160  
161 Q: Okay.  
162  
163 A: 'Cause it all happened really quickly.  
164  
165 Q: Okay.  
166  
167 A: So that's the most I can remember about him.  
168  
169 Q: OKay. You said you walked up to him.  
170  
171 A: Uh-huh.  
172  
173 Q: When you began to walk up to him from - from - from...  
174  
175 Q1: (Unintelligible).  
176  
177 Q: ...unit number 17. Was he looking at you when you walked up to him?  
178  
179 A: No - no. Uh - uh - no he was looking at the sky because he had the stick out  
180 up in the air with - the - yeah, he had the stick up in the air and he was just

181 chanting and yelling.  
182  
183 Q: Which hand did he hold the stick up in the air with? If you can remember.  
184  
185 A: Well I'm walking towards him.  
186  
187 Q: So, his back is to you at that point; correct?  
188  
189 A: His back is to me because he's, like, dancing he's, like, he's moving around a  
190 lot. I don't remember I really don't.  
191  
192 Q: Okay and then he turned around...  
193  
194 A: Uh-huh.  
195  
196 Q: ...and looked at you...  
197  
198 A: Uh-huh.  
199  
200 Q: 'Cause you're telling him that he can't be on the property correct okay.  
201  
202 A: Uh-huh.  
203  
204 Q: So, he understood you and he turned around? Um, you said he looked at you  
205 but...  
206  
207 A: It's like he looked right through its d- it didn't even - there was no real eye  
208 contact. But he was staring at me, I mean but it's like - it's like he didn't - it's  
209 like he didn't see me.  
210  
211 Q: Okay, okay. And then you said there was a machete that he had that appeared.  
212 Do you know where it appeared from?  
213  
214 A: When he had the stick in the han- in his hand which I don't know if it was his  
215 left or right. This hand always stayed to the side for those few seconds. It ne-  
216 he never reached it up.  
217  
218 Q: Okay.  
219  
220 A: It was always on the side, so I don't know if it was in his hand just held very  
221 close to his body. I - I don't know.  
222  
223 Q: Okay. You just mentioned with your right hand, do you believe the machete  
224 was in the right hand you patted your right side or you're not sure which hand  
225 it...

226  
227 A: Not real - I can't really remember.  
228  
229 Q: Okay.  
230  
231 A: Honestly 'cause he was moving.  
232  
233 Q: Okay - okay. And he did bring it up then.  
234  
235 A: Yes.  
236  
237 Q: And you saw it?  
238  
239 A: Yes.  
240  
241 Q: Did he come at you with it?  
242  
243 A: He did not come directly at me with it, he put it up in the air, you know. I just  
244 wheeled around and started running to the house.  
245  
246 Q: Okay.  
247  
248 A: I heard him tell him - tell his dog to get me and then I heard his footsteps and  
249 I'm gonna be honest with you. I did not look back.  
250  
251 Q: Okay.  
252  
253 A: I just ran.  
254  
255 Q: Okay. You were fearing for your life?  
256  
257 A: Extremely. Because I didn't know at that point did, he have any other  
258 weapons on him. Did he have a gun, did he have another knife, you know,  
259 was he an expert marksman, was, you know, I don't know - I don't - I've  
260 never seen this guy.  
261  
262 Q: Okay. How tall are you?  
263  
264 A: I'm 5'6".  
265  
266 Q: How - how big do you think this male was that you saw?  
267  
268 A: He was a good head taller than I am.  
269  
270 Q: Over six feet tall?



271  
272 A: I don't think over six. I...  
273  
274 Q: Okay but taller than you?  
275  
276 A: Yeah taller than me.  
277  
278 Q: Big guy, muscular?  
279  
280 A: Girth wise, yes, muscular.  
281  
282 Q: Okay - okay and when you ran in you never looked back but you're able to get  
283 into...  
284  
285 A: I got in the house and I locked the door and that's when I called 911.  
286  
287 Q: Okay.  
288  
289 A: And then I didn't stay in the front room because that door only has a deadbolt  
290 on it so then I went to the back of the house, went into a bedroom that had a  
291 window much further down from the front door in case he got in. I could  
292 break the window and leave. So, I was trying to find a way to get out just in  
293 case, but the whole time I was on the phone to 911.  
294  
295 Q: Okay.  
296  
297 A: And she kept me on the phone until the police arrived.  
298  
299 Q: Okay. Um, you said there's a retaining wall, where is that in relationship to  
300 unit number 17.  
301  
302 A: Unit 17 actually sits probably within I'd say eight feet of the retaining wall.  
303  
304 Q: Okay.  
305  
306 A: So, the retaining wall helps keep Oak Creek out from flooding us. So yeah  
307 probably eight to ten feet, if I was coming out of 17 it would be to the left.  
308  
309 Q: Okay so that would be to the south then - of the unit okay. You said he was  
310 chanting, what did it sound like? Was it, like, Native American chanting or...  
311  
312 A: And his dancing even kind of resembled Native American...  
313  
314 Q: Okay.  
315

316 A: ...at one point.  
317  
318 Q: Okay.  
319  
320 A: When he was on the retaining wall, why?  
321  
322 Q: Okay I'm not trying to put words into your mouth...  
323  
324 A: No - no - no the - no it's because I was telling - I was telling my - my husband  
325 about it and I said that it was almost, like, it was chanting and it was almost  
326 like he was doing a Native American step, on the retaining wall. And - and  
327 plus he had that big walking stick that had - I do remember this - it had a lot of  
328 feathers and I think beads on it 'cause it was it - you could hear the noise. Of  
329 the - of the stick when you moved it.  
330  
331 Q: You said at one point that it appeared his vest was open and that he was  
332 drawing the machete, like, across his chest, like, in a cutting type fashion.  
333  
334 A: He - he took the machete after he opened his vest, he took the machete and  
335 blade to him pointed to his chest and he started to do this and I that's when I  
336 said to the 911 operator "Where are the police? 'Cause it looks like he's doing  
337 some kind of a ritual, and I think he's gonna cut himself." You know, and -  
338 but he did it - he did it, like, once right in this area. He went all the way down  
339 his chest.  
340  
341 Q: Mm-kay for the tape you made the movement...  
342  
343 A: Oh.  
344  
345 Q: Could you explain the movement for me please?  
346  
347 A: He went the full - the - he went across his entire chest. Um, what would this  
348 be, horizontally? Yes.  
349  
350 Q: Across his ribcage?  
351  
352 A: He went across his entire chest several times, you know, but he - he started at  
353 the top and he ended at the bottom and that's when the police got there.  
354  
355 Q: Mm-okay and you remained on the phone with the police unt- or the 911.  
356  
357 A: 911 yeah.  
358  
359 Q: Okay. When the police arrived, they told him to get off of the wall, is that  
360 correct to your recollection?

361  
362 A: I remember them s- yelling, "Get down -get down" because that retaining wall  
363 is probably about four feet high at that point because it was right by the big  
364 tree. It's about four feet high yeah. So, they were saying, "Get down - get  
365 down." Eventually he got down. And he got down, but he still had everything  
366 going on and they were still yelling to stop, put it down - put it down. I don't  
367 even remember how many times they yelled it, but they just yelled it over and  
368 over again. And - and he didn't stop.  
369  
370 Q: Okay well let me take you back just for a moment, when - when the police  
371 arrived do you see where the police - the Sedona Police are?  
372  
373 A: Yeah.  
374  
375 Q: And how many units? Could you tell me where they were and how many units  
376 arrived on scene and how many officers please?  
377  
378 A: Three police cars showed up, one by one. But they were right in back of each  
379 other. You know, so they arrived within seconds of each other. When they  
380 were yelling at him at the wall. The officer that arrived first got out first and  
381 he already had his gun drawn. The second car pulled up and that officer was  
382 out right quick as well, the third one pulled out same thing - same thing. You  
383 know, out of the cars, guns drawn, yelling for him to get off the wall. When he  
384 got off the wall they kept saying and yelling to put it down - put it down -  
385 drop the weapon, you know, I can't remember all of it. And he didn't.  
386  
387 Q: And from where you were it was clear you could hear those commands being  
388 given.  
389  
390 A: Oh, I could - I'm never gonna forget that. I saw the whole thing.  
391  
392 Q: Okay.  
393  
394 A: You know. He just didn't - he just wouldn't stop.  
395  
396 Q: Was he facing the officers while they were yelling?  
397  
398 A: He even opened up his vest.  
399  
400 Q: Okay.  
401  
402 A: At the officers and said, "Are you gonna shoot me? Shoot me, go ahead and  
403 shoot me. What are you gonna shoot me?"  
404  
405 Q: Okay.

406  
407 A: Like he was questioning these guns that are already on him.  
408  
409 Q: Okay.  
410  
411 A: Because at the time now when all this is happening, you know, God- I'm  
412 trying to remember the dog - the d- I - I - the dog didn't get shot. I think the  
413 dog just took off, you know, but why all of this was happening, I don't know  
414 it was just so surreal. It was, like, watching tv.  
415  
416 Q: Okay, okay. I'm - I'm going to stop right there and I'm gonna let Detective  
417 Ellis - I would like to come back to this time, but I know that Detective Ellis,  
418 um, if you have any questions for follow-up please.  
419  
420 Q1: Uh, first off have you ever seen this gentleman before?  
421  
422 A: Never in my life.  
423  
424 Q1: Okay, um, and then earlier when you were talking 'bout - I know Detective  
425 Ruble mentioned - or was trying to get you to say that you thought the  
426 machete was in the right hand but my understanding is that it was just the  
427 opposite hand of what he had the stick in correct? That he kept putting down  
428 by his waist okay.  
429  
430 A: Mm-hm.  
431  
432 Q1: Um, and I know you had your - or it looks like you have a smart phone did  
433 you record any of the interaction with him, prior to this?  
434  
435 A: No - no.  
436  
437 Q1: Just making' sure.  
438  
439 A: No.  
440  
441 Q1: Um, and then you were on the phone with 911, when did you hang up when  
442 the officers arrived or were you still on the phone with them?  
443  
444 A: She actually said this to me she said I see - I see that my officers are on  
445 property.  
446  
447 Q1: Mm-hm.  
448  
449 A: She goes be safe take care and actually I think she disconnected.  
450

451 Q1: Okay. So, you hung - or the phone call was ended before you came out?  
452  
453 A: It was ended, yeah.  
454  
455 Q1: Okay.  
456  
457 A: It was ended and that's when I walked out to the porch.  
458  
459 Q1: Okay.  
460  
461 A: Because the police were there.  
462  
463 Q1: And how - how did you know it was the - the police?  
464  
465 A: The 911 operator told me they were on property.  
466  
467 Q1: Right. And when you walked outside how - how did you know that it was the  
468 police by their uniform, by their vehicles? How did you know?  
469  
470 A: Because all the - at that point in time when I walked - when I walked out to  
471 the porch - to the porch the minute she said they were on property, that's when  
472 they were all coming up the drive. Everybody had their, um, lights on.  
473  
474 Q1: Okay.  
475  
476 A: I don't think they - I can't - somebody had a siren and I don't know if it was a  
477 police officer or the ambulance that followed.  
478  
479 Q1: Okay.  
480  
481 A: Okay, um, so that's how I knew they were the Sedona Police and then - and -  
482 and their uniforms and their guns are drawn.  
483  
484 Q1: So, from your vantage point it was very clear that it was the - that the police  
485 department was on scene with him?  
486  
487 A: Absolutely.  
488  
489 Q1: Okay and their patrol cars are they marked or...  
490  
491 A: Yes.  
492  
493 Q1: ...are they unmarked.  
494  
495 A: They're black - they're black and then they have Sedona Police written across

496 the side of them in multiple colors.  
497  
498 Q1: Okay and then from - I know you walked out of the - the residence once they  
499 got there. How far away from there did you - did you walk to? Did you make  
500 contact with any of the officers?  
501  
502 A: No - no - no.  
503  
504 Q1: Okay.  
505  
506 A: Once I saw the guns no...  
507  
508 Q1: Okay.  
509  
510 A: My feet did not leave the porch.  
511  
512 Q1: Okay.  
513  
514 A: I just stood there.  
515  
516 Q1: So, you're still at the same spot as the - the house or the porch. Um, any  
517 obstructions in your view of...  
518  
519 A: No.  
520  
521 Q1: Any of the officers or the man.  
522  
523 A: There's several sycamore trees, but where the gentleman was standing, and  
524 the police were there are no trees.  
525  
526 Q1: Okay and what would you estimate the distance between them and the  
527 officers?  
528  
529 A: Between wha...  
530  
531 Q1: The distance between the gen- the gentleman and the officers where they were  
532 positioned. If you had to make, like, a reference point inside your house to - to  
533 help, go ahead.  
534  
535 A: You mean at the final - the final?  
536  
537 Q1: Er - maybe, like, when you first walked out how far apart were, they?  
538  
539 A: Well he was on the retaining wall and they were all still by their cars, so...  
540

541 Q1: And again, it's just a rough estimate it's not...  
542  
543 A: Take this - take this room and add another half to it. Take these two rooms  
544 and add a maybe another half - no that's too far. I would just take these two  
545 rooms.  
546  
547 Q: This is one room so...  
548  
549 A: Yeah whatever.  
550  
551 Q: 20 feet?  
552  
553 A: 20 feet. Yeah, about 20 feet.  
554  
555 Q1: Roughly?  
556  
557 A: Yeah.  
558  
559 Q1: Okay.  
560  
561 A: Yeah.  
562  
563 Q1: And then when he comes off the retaining wall, um, is he walking towards the  
564 officers?  
565  
566 A: Yeah, he is the whole time he's walking towards them. The entire time.  
567  
568 Q1: How would you describe his walk? Is it, like, a brisk walk is he walking just  
569 nonchalant?  
570  
571 A: It was - no it wasn't very n - it wasn't nonchalant, it was more like, um, there  
572 was an attitude to it.  
573  
574 Q1: Okay so...  
575  
576 A: Because that's when he did the - the vest thing. It was more - it was - if I had  
577 to describe that walk it'd be like a swagger.  
578  
579 Q: Okay.  
580  
581 A: Almost.  
582  
583 Q1: Is it quick, slow? I know you said with attitude...  
584  
585 A: It's kind of slow it's not very quick.

586  
587 Q1: Okay.  
588  
589 A: It's not very quick I mean he's not - he's not, like, running towards them.  
590  
591 Q1: Mm-hm.  
592  
593 A: But he won't put anything down.  
594  
595 Q1: Yeah and he's still holding both the stick and the machete?  
596  
597 A: Yeah, he's got everything his hands are full the whole time, you know, and  
598 then whenever he doesn't have his - his walking stick and his machete here.  
599 He - down here by my shoulders he seems to go up to the air again.  
600  
601 Q1: Okay.  
602  
603 A: So, there was just - those are some of the movements I remember.  
604  
605 Q1: And then when - when the - the officers do end up discharging their weapons  
606 how far apart were they at that point? Again, if you have to use the room as a  
607 reference.  
608  
609 A: Maybe ten, 12 feet.  
610  
611 Q1: Okay. So, he's - he's 'bout half the distance that he's - then when he started?  
612 Going back to when you first made contact with him. Did he make any  
613 statements to you or he's just looking through you?  
614  
615 A: He just stared through me. He didn't say a word to me he just kept chanting.  
616  
617 Q1: Okay does he recognize that you were trying to talk to him or do you - do you  
618 feel that he just kept (unintelligible).  
619  
620 A: I honestly can't answer that because he never - it's never like he  
621 acknowledged me talking to him.  
622  
623 Q1: Okay.  
624  
625 A: And - and his eyes were very - there was just something very different about  
626 them. And I - I can't even explain it to you, they were very just cold and just -  
627 I don't know, like, they stared right through you, but he didn't acknowledge  
628 me to me. He didn't acknowledge my presence at all until I turned around and  
629 I heard him say, "Go get her." And that was what he was saying to the dog.  
630



631 Q1: That's the only time that he actually seemed like he was talking to you?  
632  
633 A: That's it that's the only time that he actually seemed like he was talking to me.  
634  
635 Q1: And just before that when you started to walk away did, he - did his eyes track  
636 you or did it still...  
637  
638 A: I don't think so.  
639  
640 Q1: Oh okay.  
641  
642 A: Uh, no.  
643  
644 Q1: And then when the officers do show up on scene, I know you've - you've  
645 talked about them making the comments - or the commands of dropping -  
646 dropping' the weapons. Did they ever identify themselves as Sedona Police  
647 Department?  
648  
649 A: Oh yeah.  
650  
651 Q1: Okay and that was verbal?  
652  
653 A: Yes.  
654  
655 Q1: Okay.  
656  
657 A: Yes.  
658  
659 Q1: And were the lights still on when they got out or were, they off at that point?  
660  
661 A: They were on.  
662  
663 Q1: Okay. That's all I got John.  
664  
665 Q: And you heard those commands clearly?  
666  
667 A: Oh absolutely.  
668  
669 Q: When they came up to the scene and they exited their vehicles and they stated  
670 Sedona Police Department or Sedona PD, and you heard them?  
671  
672 A: Absolutely I heard them identify themselves.  
673  
674 Q: And you were quite a ways away so at the house?  
675

676 A: I'm on the porch outside at the house.  
677  
678 Q: Okay.  
679  
680 A: Yes.  
681  
682 Q: 20 yards - 30 yards away from him you think, estimate?  
683  
684 A: God I'm so bad at directions and lengths and all that kind of stuff, probably...  
685  
686 A1: The width of the property is 175 feet.  
687  
688 A: Probably 35 - 40 yards yeah, shit I don't know.  
689  
690 Q: Okay. You said it appeared he was taunting or had a swagger when he was  
691 starting to walk towards the officers, can you describe it a little bit for me?  
692 Just a little bit more. Did he, like, display the machete towards the officers or  
693 the stick or anything towards the officers in a threatening type manner?  
694  
695 A: Well I mean he - he was just basically flailing it all over the place. I mean it  
696 was up in the air sometimes, it was pointed forward sometimes, it was  
697 sideways sometimes. It was just very odd.  
698  
699 Q: Yeah.  
700  
701 A: You know.  
702  
703 Q: So, he's...  
704  
705 A: And the stick the same thing he was, like, moving the stick all over the place  
706 and like I said anytime that he wanted to make a movement with his vest. He  
707 d- he - those things were still in his hands, you know, he just, like this.  
708  
709 Q: So, he made a motion that he just...  
710  
711 A: Yeah.  
712  
713 Q: ...opened his vest.  
714  
715 A: Yeah and that's when he was, like - and by a swagger I mean somebody over  
716 exaggerated body movements. I guess would be what I would say it would be,  
717 because he was like, you know, what are you gonna shoot me, you know, and  
718 I'm like.  
719  
720 Q1: Okay. Before the officers had fired did you feel that he - hold on a second.

721 From your perspective of where you're at and the officers and where the male  
722 is, um, and as he's kind of slowly advancing onto them. Um, what do you  
723 think the outcome would have been if he would have just dropped the - the  
724 machete?

725  
726 Do you think...

727  
728 A: He'd be in jail right now.

729  
730 Q1: Okay so there - you don't - in your mind you don't believe that the shooting  
731 would have occurred if he would have listened to the commands? At least  
732 from your perspective.

733  
734 A: I don't - no I don't th- no I don't think that would've occurred at all had he  
735 listened to the commands.

736  
737 Q1: Okay.

738  
739 Q: That was my question what could he have done differently to change the  
740 outcome of this?

741  
742 A: Just put the machete down.

743  
744 Q: Okay.

745  
746 A: It's all he had to do.

747  
748 Q: Okay - okay.

749  
750 Q1: All right. That's it.

751  
752 Q: I don't have any further.

753  
754 Q1: Before we turn the recorder off, I just want to get on record, um, her son Erick  
755 is that correct? And how do you spell your first name?

756  
757 A1: E-R-I-C-K.

758  
759 Q1: Um, he's the other - the voice that you would hear on the recorder just helping  
760 with the - the distance and the property layout.

761  
762 Q: I have nothing further, ma'am do you have any further before we go off tape?

763  
764 A: No.

765

766 Q: Okay. Then we're going to stop the tape at 1822 hours or 6:22.

767

768

769 The transcript has been reviewed with the audio recording submitted and it is an accurate  
770 transcription.

771 Signed, John D. Ruble, #5627 January 30, 2020



**ARIZONA DEPARTMENT OF PUBLIC SAFETY**  
**INTERVIEW SUMMARY**

<b>DR NUMBER:</b>	<b>I20003903</b>
-------------------	------------------

Person Interviewed: Susan Frohman

Date of Birth: [REDACTED]

Occupation: Retired

Residences: [REDACTED]

[REDACTED]

Telephone: [REDACTED]

**Interview Summary**

On January 20, 2020, Susan Frohman was interviewed by Arizona Department of Public Safety (DPS), Coconino Criminal Targeting Unit (CCTU) Detective Jared Gray, badge number 7505. This interview was conducted at [REDACTED].

The digitally recorded interview commenced at approximately 1734 hours and concluded at approximately 1750 hours. The digital recording was subsequently transferred to a digital media disc and provided to the case agent, Detective Andrew Reed.

The following is not a verbatim transcription of the interview with Frohman:

At the beginning of the interview, Frohman was informed who I was. Frohman was asked if she saw or heard the incident. Frohman informed me what she was going to tell me was from her point of view and she documented such in writing. Frohman provided me with her full name, addresses, social security number, cellular telephone number and her DOB.

Frohman explained prior to the incident she was outside walking her dog. While walking her dog, a three-legged pit bull showed up. Frohman brought her dog back inside of her house. When she went back outside, the pit bull was lying down on the ground outside of her residence. The pit bull appeared to be healthy which indicated to Frohman the dog was safe. Frohman obtained a leash and put it on the pit bull. Frohman believed the pit bull lived nearby. Frohman walked the pit bull up a gully, at which time the pit bull immediately pulled Frohman in the direction of the residence near Frohman's.

Frohman walked the pit bull up to the residence through the driveway. Frohman saw two males inside of the residence. Frohman did not approach the door. Frohman obtained their attention and pointed down at the pit bull. The males came outside. Frohman described the males as "high as kites." The males identified the pit bull as theirs. Frohman removed the leash from the dog.

Frohman was asked to describe the residence. Frohman stated it was the residence up the road from her house and behind a bamboo fence. (It should be noted the residence Frohman described was the residence located at 71B New Castle). Frohman was asked if she observed a vehicle parked outside of the residence. She could not recall if she did or not.

Detective Name	ID No.	Location	Date	Supervisor
Detective Jared Gray	7505	31010100	01/21/2020	Sergeant Will Willis



**ARIZONA DEPARTMENT OF PUBLIC SAFETY**  
**INTERVIEW SUMMARY**

<b>DR NUMBER:</b>	<b>I20003903</b>
-------------------	------------------

After the pit bull was released from her leash, she proceeded back to her house. Once at her house, she sat outside on her patio which faced Oak Creek. After approximately 10 minutes (also described as a relatively short period of time), Frohman heard chanting. Not knowing what it was, Frohman stood up to look at who or what was making the noise. Frohman observed a heavier set male sitting on a berm located on the other side of the fence. Frohman recognized the male as one of the subjects she released the pit bull to. Frohman observed the male sitting on the berm with a wooden stick and feathers.

*Investigator note: I asked Frohman if she could describe what she meant when she earlier stated the male subjects were high as a kite. She stated they were glassy eyed, and she did not know how else she knew. She stated there were drugs involved, although she could not elaborate any further.*

Frohman explained while she was seated next to the fire pit on her patio, she heard yelling and chanting. Frohman did not give the noise much attention because she often hears live music from the resort located close to her residence. After hearing the noise, Frohman stood up and looked around. When Frohman looked in the direction from where the noise was coming from, she observed the heavier set male of the two guys she dealt with sitting on the berm closest to 65 New Castle Lane.

Frohman observed the male chanting and “carrying on” with the stick which had feathers on it. Based on his actions, Frohman believed the male was involved in a religious ritual practice of some sort. Frohman sat back down and thought about calling Cheryl (Harrell) who supervises the property the male was on.

Next, Frohman heard gun shots. After hearing the gun shots, she went inside of her house and called 911. 911 informed Frohman police officers were already on-scene and she should remain in her house. Frohman never saw the police cars arrive on-scene or witness the shooting. Frohman only heard the gun shots.

Frohman again stated she was outside at the time she heard the gun shots. At my request, Frohman was asked to accompany me outside and show me where she was seated at the time of the incident. Outside, Frohman showed me where she sat when her attention was called to the chanting. Frohman pointed in the direction of 65 New Castle Lane and stated she observed the male through square tubing fence of the residence.

Frohman described the heavier set male as having spikey hair with torn clothing. Frohman believed he had tattoos, but she could not be specific. Frohman confirmed the subject whom was near the berm, chanting and involved in what she believed as a religious ritual practice as the same guy she dealt with when she returned the three-legged pit bull.

Prior to observing the male chanting and engaged in a ritual practice, Frohman has never seen

Detective Name	ID No.	Location	Date	Supervisor
Detective Jared Gray	7505	31010100	01/21/2020	Sergeant Will Willis



**ARIZONA DEPARTMENT OF PUBLIC SAFETY**  
**INTERVIEW SUMMARY**

<b>DR NUMBER:</b>	<b>I20003903</b>
-------------------	------------------

him. Frohman did not know his name.

Frohman's husband was home at the time of the incident. He did not see or hear anything.

Frohman thought the incident occurred between 1330 hours and 1400 hours, but she was not sure.

Frohman described the noises coming from the male located near the berm as chanting and yelling. The subject was not chanting words, just noise.

Frohman was asked if she observed anything in the male's hands. The only object seen was a five-foot wooden pole with feathers.

Frohman again stated she did not see or hear police officers arrive on-scene. She heard the gunshots which caused her to go inside of her house.

Detective Name	ID No.	Location	Date	Supervisor
Detective Jared Gray	7505	31010100	01/21/2020	Sergeant Will Willis



**ARIZONA DEPARTMENT OF PUBLIC SAFETY**  
**INTERVIEW SUMMARY**

<b>DR NUMBER:</b>	<b>I20003903</b>
-------------------	------------------

Persons Interviewed: Peter McLoughlin and Jovan Quinn Keeley-McLoughlin

Residence: [REDACTED]

Telephone: [REDACTED]

**Interview summary**

On Monday, January 20, 2020, at 1753 hours, Arizona Department of Public Safety (DPS), Special Investigations Unit (SIU), Detectives John D. Ruble, #5627, and Kenneth Ellis, #6659, interviewed Peter McLoughlin and his son, Jovan Quinn Keeley-McLoughlin. The interview was conducted in the Incident Command Van located on Juniper Lane, Sedona, Arizona. The audio recorded interview commenced at 1921 hours and concluded at 2008 hours. The audio recording, evidence item JDR2, was submitted into the DPS Central Regional Property and Evidence (CRPE) Section located at 2323 North 22<sup>nd</sup> Avenue, Phoenix, Arizona for storage.

The criminal interview pertained to Peter McLoughlin’s and Jovan Quinn Keeley-McLoughlin’s involvement in an officer-involved shooting investigation which occurred at 55 Newcastle Lane, Sedona, Arizona.

In summary, Peter McLoughlin provided the following information:

Peter said he had met Johnathan Messare through his son, Jovan, approximately two weeks ago.

Peter said he was aware Messare had been evicted from his music studio called “Steady Rhythms” located on Contractors Way, Sedona. Peter said his son, Jovan, had offered Messare their home as a place to stay temporarily.

Peter said he had learned Messare was an Iraqi war veteran and it, “seemed like he probably suffered from post-traumatic stress disorder (PTSD), from the things he’d been through.”

Peter said he was not at his residence on the evening of Sunday, January 19, 2020 when Messare stayed over. Peter said he received a phone call from his son, Jovan, on Monday, January 20, 2020 and was told Messare had been shot. Peter said he returned home.

In summary, Jovan Harris-McLoughlin provided the following information:

Jovan said he had met Messare approximately two months ago and considered him a friend. Jovan said during this time, Messare had shared some of his personal life information and told Jovan he had been placed into an orphanage as a young child, at eight years old, and he did not know his mother or father. Messare told Jovan he has a brother, Mark, who is incarcerated in Kentucky.

Detective Name	ID No.	Location	Date	Supervisor
John D. Ruble	5627	31030200	02/11/2020	Sergeant Jeromy McDonald, #6513





**ARIZONA DEPARTMENT OF PUBLIC SAFETY**  
**INTERVIEW SUMMARY**

<b>DR NUMBER:</b>	<b>I20003903</b>
-------------------	------------------

Jovan said Messare told him he had been in the military serving in Iraq where he had been injured and received a monthly pension. Messare told Jovan his wife and their four children had disappeared three years ago, and he has no idea where they are.

Jovan said Messare told him of an altercation he had with the Portland, Oregon Police Department. Jovan said Messare had fought with the Oregon police officers, was naked, and running through a school yard. Jovan said Messare had a machete with him during that altercation. Jovan said, "we'd known about his Portland thing that he'd done, and stuff and we knew that he was a little mentally unstable, definitely."

Jovan said Messare needed a place to stay and he had invited him to his home on Sunday, January 19, 2020. Jovan said Messare brought over several items from the music studio along with clothing, which had been packed in a military-style backpack. The music studio items, and clothing had been placed in the living room. Jovan said Messare left his cell phone in the living room. Jovan said he did not know the name brand of the cell phone but recalled the cell phone had the letters "CAT" marked on the case.

Jovan said on the morning of January 20, 2020, Messare seemed relaxed as he spoke of his wife and kids after he and Jovan had listened to a compact disc (CD) containing music Messare and his wife had made together. Messare began making statements Jovan did not understand. Jovan recalled Messare saying, "what about my wife and kids, I've lost my stars, and a sky with no stars is a black night." Jovan said, "it was almost like he was having a nervous breakdown or something about his wife, he was crying that morning, he was, yeah, just acting really emotionally distraught." Jovan said it seemed to him Messare was "just broken because he does not have his wife and children and that was his whole foundation of his whole life."

Jovan said Messare was drinking beer and did not appear drunk, "but he seemed, like, kind of drunk."

Jovan said Messare went out to the front yard of the residence and began to call out military-type cadence, was loud, and was carrying a sword. Jovan said, "he was one of those, like, persons that, like, been in war before so it seemed, like, he was preparing to go to some kind of war."

Jovan said he tried to get Messare to calm down, however, he did not respond to Jovan's request and continued to yell out the military cadence. Jovan said Messare's actions with the sword intimidated him and made him feel uncomfortable, so he went into his residence and locked the door. Jovan said before Messare walked away he recalled him saying, "oh Father Christmas is going come back and he was going meet the lord today." Jovan said thinking about what Messare said to him made him think maybe his friend had contemplate suicide by police.

Peter McLoughlin interjected, "yeah, it seemed like a, like a suicide by police."

Detective Name	ID No.	Location	Date	Supervisor
John D. Ruble	5627	31030200	02/11/2020	Sergeant Jeromy McDonald, #6513



**ARIZONA DEPARTMENT OF PUBLIC SAFETY**  
**INTERVIEW SUMMARY**

**DR NUMBER:**

**I20003903**

Jovan said as Messare walked away, he heard him say, "I can't deal with this, and it's too much," pulled out his sword, and walked away from the residence. Jovan said he felt Messare was going to "start stuff in the neighborhood." After he went to his house, he could hear Messare calling out military cadence as he walked away. Jovan said he could hear him for quite some time after seeing police vehicles drive by his home. Jovan became worried something like what had occurred between Messare and the Oregon Police Department might happen again.

Jovan said he recalled hearing someone say, "put your weapon down." Jovan said he believed it was the police he heard giving that command. He heard what he described as "four blasts."

Detective Name	ID No.	Location	Date	Supervisor
John D. Ruble	5627	31030200	02/11/2020	Sergeant Jeromy McDonald, #6513

**INTERVIEW WITH PETER QUINN MC LOUGHLIN**

**Q=Det. John D. Ruble**

**Q1=Det. Kenneth Ellis**

**A=Peter Quinn Mc Loughlin**

**A1=Joven Quinn Keeley Harris - Mc Loughlin**

1  
2  
3  
4  
5  
6  
7  
8  
9  
10  
11  
12  
13  
14 Q: Today is January 20th. The time is 1921 hours. We are in Sedona in an officer  
15 involved shooting. Tonight, we are with two friends of Jonathan Messare, um,  
16 for the tape, uh, I have, uh, Detective Ellis. Could you please identify  
17 yourself?  
18

19 Q1: I'm Detective Ellis, badge number 6659. Last name's spelling, E-L-L-I-S.  
20

21 Q: And we have two friends of Messare. Um, Peter if you'd go ahead and  
22 identify yourself please?  
23

24 A: Yeah, my name's, uh, Peter Mc Loughlin, uh, last name's spelled M-C L-O-  
25 U-G-H-L-I-N and also, um, another friend of, uh, Mr. Messare.  
26

27 A1: My name is Joven Harris - Mc Loughlin, and that's spelled, my last name is  
28 spelled, H-A-R-R-I-S - M-C L-O-U-G-H-L-I-N.  
29

30 Q: Joven for the tape could you spell your first name too?  
31

32 A1: J-O-V-E-N sir.  
33

34 Q: Thank you. Tonight we're - we're, um, uh, conducting interviews concerning,  
35 uh, an officer involved shooting. Um, what can you two tell us about Mr.  
36 Messare?  
37

38 A: Well I have least to say so I guess I'll get - get my bit done. Okay well, um,  
39 Joven - my son Joven met these guys up in West Sedona. Um, he seemed like  
40 a - he's a really nice guy, he was really cool he was, uh, Vietnam. No not  
41 Vietnam, uh, Iraq veteran. Um, seemed like he probably suffered from PTSD  
42 from the things he'd been through.  
43

44 A1: Which I can agree.  
45

46 A: Um, so anyway, uh, so I - I don't really - I've only known this person, uh,  
47 probably a couple of weeks. Um, I don't know him that well but Joven got to  
48 know him and, um - um, the guy he, uh, got evicted from his place. He didn't  
49 have a place to live anymore so he needed a place to come down for just for a  
50 day that he said he wanted to set up his gear and, you know, so we tried to  
51 help him out basically. Uh, then today, uh, I wasn't actually here. My son  
52 called me, crying hysterically saying, you know, his friend Johnny had been  
53 shot. And so, I rushed home as soon as I can to come console my son and  
54 that's pretty much as much, you know, as I can pretty well give you. Um, you  
55 know, I - I didn't. I knew Johnny was in the house, you know, he stayed there  
56 for the night, right?  
57

58 A1: Yeah and I introduced him to my father.  
59

60 A: And, um, you know I said yeah, we can help this guy out, you know, he can't  
61 stay forever but we can help him out. And, um, so I wasn't actually here last  
62 night I just - I spent time at my girlfriend's house so Joven was here with  
63 Johnny last night, right?  
64

65 A1: Yeah, I was here with Johnny last night. So I met Johnny, um, up - up at a  
66 studio in West Sedona, um, he had a studio - commercial studio building but  
67 he wasn't allowed to sleep in it and the guy tol- he ended up sleeping in it so  
68 the guy told him, um, he had to get out. And, uh, Jonathan just messaged me,  
69 and he just met me recently and he wanted a friend that he thought had his  
70 back. And I said, you know, like, because I haven't had very many friends out  
71 here other than just my girlfriend of three years (Tara). And, uh, anyway, uh, I  
72 said yeah you can come by, you know, and, uh, spend the night with me. Uh, I  
73 had spent a little bit of time with him beforehand at the studio. Uh, I'd visit  
74 him, like, you know, like, maybe three times a week. Uh, I've only known  
75 him for about I'd say less than two months. A month and a half and, um,  
76 Johnny, uh, he just yeah, he seemed, like, really just sad last night. And so  
77 anyway I wanted to talk to him as a friend and be, you know, his friend, you  
78 know, console and he, um, was telling me that he lost his wife and his  
79 children, and he was really just emotionally distraught. And he was also a  
80 little PTSD from the war and I just wanted, you know, I wanted to be his  
81 friend, like he would for me because he was very nice to me. And he was very  
82 polite and kind. So anyway, I let him spend the night and, uh, this morning he  
83 woke up, uh, he, um, started progressively, uh, like, hinting at things that were  
84 making me feel, uh, uncomfortable a bit. And - and a little uneasy in my own  
85 house, and those - those things were, uh, basically, like - like, little short  
86 comments, like, oh what about my wife and kids, I've lost my stars and, like,  
87 just real figurative language. And I didn't, like, quite understand.  
88

89 A: Made more sense later on, right?  
90

91 A1: Yeah so anyway I was talking to Johnny it didn't seem to, like, quite make  
92 sense. He didn't seem quite right and, um, like, he just seemed real distraught  
93 and stuff. So, then he played me his wife's CD, uh, which was the last thing  
94 they recorded apparently before, uh, he - I don't know if she left him or if  
95 something happened in the family. And the kids got separated from him  
96 somehow. I really don't know 'cause he do- he wasn't very clear about that  
97 but, um, he was just clear with me that he lost his wife and his kids and he's  
98 really distraught about it, so, um, I know that previously a few months ago in  
99 Portland, Oregon he had fought, uh, police officers naked with a ma- machete  
100 and then he took off all of his gear. Um, so I knew that he was potentially  
101 known to do this thing and anyway, uh, as the morning progressed into  
102 afternoon, I don't know quite the time that it even happened but, uh, Johnny  
103 started getting on, like, um, he used to be apparently, like, a drill sergeant and  
104 he started doing, like, uh, left - left - left - right - left. Like, he started saying,  
105 like, drills. And he started being really weird to me and I'm, like, Johnny, like,  
106 cool down a bit, like, we're outside of my house and I have neighbors and  
107 stuff so don't be out here just being obnoxious. And anyway, uh, I talked to  
108 him for a few more minutes and then he, uh, goes about he carries all these,  
109 uh, swords with him all the time. He always carries swords and knives and  
110 hatchets with him because he is a veteran I guess and he's trained with his, uh  
111 - uh, he's trained with the IDF apparently and, uh, hand to hand combat and  
112 stuff. So, he, uh, anyway he said, like, ah I can't deal with this it's too much.  
113 So he went to the right - well from my house - to the right down there where  
114 the dip goes down and he left and I felt - I felt that, like, he was gonna start  
115 stuff in the neighborhood because his dog was loose and stuff and I was really  
116 just kind of anxious about my own place of living and stuff 'cause I - I  
117 appreciate a lot of those things too 'cause obviously he didn't have one for his  
118 own reasons. Um, anyway, uh, he, uh, just said ah it's too much, like,  
119 basically and then he pulled out his sword and he started, uh, going down the  
120 road down there and then, uh, I was like oh no. So, I went in my house and I  
121 locked my door 'cause I didn't think he would, uh, you know what I mean if  
122 he came back. He was being a little bit taunting though with me I don't like  
123 him with a big blade on his shoulder. It was a little bit, uh, taunting. But, uh,  
124 he's just known to do that and he, like, - he, like, plays with it and practices  
125 with it so he just is one of those military type training people. Anyway, um, he  
126 went down the road and then I went in and locked my door, he, uh came back  
127 out - well, uh, he didn't come back out - I came back out after I heard four  
128 blasts. Uh, and then my stomach just sank, and I was like oh no, is he doing  
129 something again, like, he did in Oregon, like, with his machete. Uh, or not  
130 machete but sword and the neighbor comes out and starts praying and we start  
131 praying a little bit to Jesus. And 'cause Johnny was a real religious type so we  
132 started praying to Jesus and, uh, she, you know, I go into shock because I was  
133 afraid that he, you know, was gonna repeat this again. And if you go - if you  
134 go with that kind of behavior obviously, you know, the police are gonna re-  
135 react to that. So, I was just super scared for him. And, uh, after I heard those

136 four blasts, I was like no. Me and the neighbors are all holding hands and just,  
137 like, praying for him. Then the ambulance never came back and we were like  
138 oh we hope he's not gone 'cause, like, uh, my neighbor (Kimberly) said oh I  
139 saw your friend with his dog and he said he didn't seem like he'd hurt a fly.  
140 He seemed a little, you know, off a little bit, uh, just not, like...

141  
142 A: I would have never let him out in our house if I felt that he was gonna harm  
143 us. He - he never really seemed...

144  
145 A1: He wasn't - he wasn't, like, taunting like that.

146  
147 A: Had a screw loose or whatever that he was gonna just flip like that.

148  
149 A1: No - no.

150  
151 A: Yeah.

152  
153 A1: And he'd never done anything like this before and all of a sudden, he just had  
154 this whole different behavior when he left and, uh, then that me and my  
155 neighbors' kind of held hands and...

156  
157 A: Yeah (unintelligible).

158  
159 A1: We, you know, kept going on and I went and jumped in the shower because I  
160 was just too distraught and I had to sit under the hot water and I was crying  
161 because I thought that he'd done the same thing he'd done in Portland.

162  
163 Q: Okay.

164  
165 A1: And he'd done something, you know. I - I was still hoping that he was okay,  
166 but it just didn't seem like it. Because the way -that sound didn't just - yeah.  
167 So, and then my neighbor lady kept telling me, like, she was like telling me  
168 that oh your friend might have passed, like, let's - let's hold prayer for him.  
169 So, um, that - that's about it there but, uh, before he left he was giving me all  
170 these weird things and he was like oh, like, just figurative language, like, oh  
171 you know father Christmas, like, uh, is - is gonna come - come back. He's  
172 gonna meet the lord today but, like, I didn't understand quite what he meant  
173 until afterwards. Like, you know what I mean...

174  
175 A: It seemed like suicide by the police.

176  
177 A1: Yeah, it seemed like a - like a suicide by police officer.

178  
179 Q: Would it be all right if I asked you a couple questions?

180

181 A: Sure.  
182  
183 A1: Yeah sure.  
184  
185 Q: So, um, this is for Peter then.  
186  
187 A: Yes.  
188  
189 Q: Um, you met Jonathan then? That's the individual that we're talking to?  
190  
191 A: Yeah.  
192  
193 Q: And he's an Iraqi veteran, do you know when?  
194  
195 A: Yeah as far as I know.  
196  
197 Q: Do you know when he came back from his military service? How long he  
198 served?  
199  
200 A1: Uh, I believe in 2007 or '08.  
201  
202 A: 'Cause I can as well.  
203  
204 Q: Okay.  
205  
206 A: Yeah.  
207  
208 Q: You - you said he got evicted from his residence?  
209  
210 A1: Uh, not his resi- it wasn't a residence...  
211  
212 Q: Studio...  
213  
214 A1: It was a commercial, uh, zoning.  
215  
216 A: Yeah, the music studio in this (warehousy) kind of a place.  
217  
218 A1: But he - he used it as a residence and that's what got him kicked out.  
219  
220 Q: And he was...  
221  
222 A1: Staying there.  
223  
224 Q: Yes, he was staying there and then he spent the night with you on the 19th?  
225 That was yesterday.

226  
227 A1: Yeah.  
228  
229 Q: That was Sunday, so he came over and said he's been kicked out of the music  
230 studio then on Sunday?  
231  
232 A1: Um, I had, uh, talked to him a bit beforehand 'cause this got established a few  
233 days beforehand.  
234  
235 Q: Oh.  
236  
237 A1: And he was just packing stuff up and tying loose ends up...  
238  
239 Q: Okay.  
240  
241 A1: And getting stuff out from his studio.  
242  
243 Q: Do you know where that studio was located or who owns that?  
244  
245 A1: Uh, it's ju- it's called Steady Rhythms it's on...  
246  
247 A: Yeah down by, um, Contractors Way. Yeah Contractors Way by Basha's.  
248  
249 Q: On Contractors Way?  
250  
251 A1: Yeah Contractors Way.  
252  
253 A: Yeah. I think it's way. I don't think it's road.  
254  
255 Q: Okay.  
256  
257 A1: And then anyway I just thought, well, I've been really cautious to meet friends  
258 and stuff and I only hung out with my girlfriend lately so I - you know,  
259 thought he was a good friend. And it was really devastating to me.  
260  
261 Q: Okay. So, he came over last night and did he bring his dog with him then?  
262  
263 A1: Yeah.  
264  
265 Q: Okay. And he has just the one pit bull?  
266  
267 A1: Yes.  
268  
269 A: Yeah.  
270



271 Q: Okay so...  
272  
273 A1: With the three legs.  
274  
275 Q: Okay and - and you knew that - and he talked was it last night or more today  
276 about losing his wife and his children?  
277  
278 A1: Yeah today he played me a CD that him and his wife made and produced  
279 together in Israel I believe or Jerusalem.  
280  
281 Q: It's a re- it's a CD of music?  
282  
283 A1: Yeah, and that was, like, shortly before maybe an hour or two before he  
284 actually left and went wild.  
285  
286 Q: What do you mean by wild?  
287  
288 A1: Wild, like, he was just saying left - left, he was doing, like, boot - what do you  
289 call it, boot chants.  
290  
291 Q1: Cadence.  
292  
293 A1: Cadence and, like, it seemed, like, well he was one of those, like, persons that,  
294 like, been in war before so it seemed, like, he was preparing to go to some  
295 kind of war. And that's what really scared me, so I went and locked my door  
296 then when he was out there with a sword and acting like that because I felt a  
297 little intimidated by him obviously.  
298  
299 Q: Okay. By any chance do you believe maybe there were - just do you know if  
300 he does drugs or alcohol or any of those things or did you notice any drugs?  
301  
302 A1: Uh, I've seen him drink alcohol quite a bit, yeah.  
303  
304 Q: Was he drinking last night?  
305  
306 A1: Uh...  
307  
308 Q: That you can remember?  
309  
310 A1: No, I believe I mean I think he maybe had a few sips of beer. I had a couple  
311 beers you know what I mean that he brought - a couple beers that he brought  
312 from his old studio.  
313  
314 Q: Do you know if he does any - any drugs or takes medication?  
315

316 A1: I believe he smokes marijuana.  
317  
318 Q: Okay.  
319  
320 A1: Um, he doesn't take any kind of medication because, uh, the VA would - he  
321 was telling me that the VA got him screwed up on opioids.  
322  
323 Q: So, no medication that you're aware of?  
324  
325 A1: No.  
326  
327 Q: Okay - okay. How was he dressed today when you were outside with him?  
328  
329 A1: Uh, I believe he had like a shirt on with cut - cut sleeves and maybe overalls  
330 but I don't - I don't know if it was either overalls or his jeans. But he was  
331 wearing a, uh, what is it called, like, a military surplus shirt but, like, with cut  
332 off shoulders.  
333  
334 Q1: Describe it as, like...  
335  
336 A1: Like, a, like, a wife beater, like, he cut off the sleeves.  
337  
338 Q: Was it open to the front, like, a vest type or...  
339  
340 A1: Uh, I - I can't say if he either wore, like his, like, jacket he had a hoodie with  
341 him.  
342  
343 Q: Oky so, um, you said he had a sword or something with him?  
344  
345 A1: Yeah, he apparently, he told me gotten a sword for his, uh, daughter for her  
346 birthday a few years ago for her to, like, play with and train with. 'Cause he  
347 was training them, you know what I mean, he was like that with his kids. So,  
348 uh, he had this out and then it was, like, it just made me feel a little  
349 uncomfortable. I'm like, Johnny just cool it down a bit, you know, and just  
350 stop being as loud. And then I finally just closed the door and locked it and  
351 then that's when he left.  
352  
353 Q: Did he have anything else with him, you mentioned the sword. Did he have  
354 anything else?  
355  
356 A1: Uh, he, uh, he did have I think a hatchet thing that he always wore it was, like,  
357 a, uh, IDF hatchet he told me. That he had gotten taken away from the, uh,  
358 Portland Police Department before and he felt like I guess he always had to  
359 have it on him because he had to get a new one after - after he got out of jail.  
360 And he gets, uh, like a wounded veteran, uh, pension every month.

361  
362 Q: He does? You - you locked your door, um, why did you go in your house and  
363 lock your door?  
364  
365 A1: Because I - I just felt a little intimidated and uncomfortable by him, like, you  
366 know, giving me cadence and the sword, I mean, the sword it was just a little  
367 intimidating.  
368  
369 Q: Was he swinging the sword?  
370  
371 A1: Nah, I mean, like, he was just kind of, like, playing with it.  
372  
373 Q: Okay. You weren't afraid or scared?  
374  
375 A1: No, not at all. He was just he always does that he always practices with the  
376 thing.  
377  
378 Q: Okay - okay. So, after he leaves - so from your house then he would walk  
379 down the street would be to the south of your place and then across the creek  
380 which would be to the east?  
381  
382 A1: Mm-hm.  
383  
384 Q: Okay did you see him walk that way...  
385  
386 A1: Um...  
387  
388 Q: Or did you just...  
389  
390 A1: Um, when I closed the door and locked it, I just saw him going down that  
391 pathway. Kind of looked out the window and made sure he wasn't standing  
392 outside my door or something, you know, so then he started walking down  
393 that pathway and I was like oh he's doing something weird.  
394  
395 Q: Okay.  
396  
397 A1: It was just, uh, he had way different behavior than normal behavior when I  
398 was hanging out with him.  
399  
400 Q: Okay.  
401  
402 A1: It was almost, like, he was having a nervous breakdown or something about  
403 his wife he was crying that morning, he was yeah just acting really  
404 emotionally distraught.  
405

406 Q: Um, you mentioned later on you heard four blasts but before that did you hear  
407 any police sirens?  
408

409 A1: I actually I saw - I was looking outside my window and I saw a police officer  
410 drive by.  
411

412 Q: How did you know they were police officers?  
413

414 A1: Because it said police on the side, it was a police vehicle and I knew that  
415 Johnny was known, like, to do things, like, this so.  
416

417 Q: Okay. Do you recall how many police vehicles drove by your home?  
418

419 A1: Uh, I just looked at the one and then I went and laid down because I was just  
420 scared because I was afraid at least he would be leaving in a police car, you  
421 know.  
422

423 Q: Did you notice any lights or sirens? Did you hear...  
424

425 A1: No, I just went in my bedroom and laid down.  
426

427 Q: Okay did you hear any loud voices or anything?  
428

429 A1: Uh, I - I heard Johnny loud outside, um, my window's broken on my - my  
430 right side of my house. And I just heard Johnny outside, and he was kind of,  
431 like, doing really loud cadence type thing - it's called cadence and he was just  
432 lou- really loud down there and I was worried about him when I saw the  
433 police officer drive by. And then he was being really loud down there, he was  
434 not acting pretty unusual not the way he would usually act.  
435

436 Q: Did you hear any other voices maybe from the police down there?  
437

438 A1: Um, I did, uh, I believe I heard them say put - put your weapon down.  
439

440 Q: Okay.  
441

442 A1: Um, yeah, I didn't want to try to listen though too much because it was  
443 uncomfortable to me, you know, just because...  
444

445 Q: 'Cause that's your friend.  
446

447 A1: Yeah.  
448

449 Q: And - and he was acting irrational.  
450

451 A1: Yeah.  
452  
453 Q: And you were worried for his safety.  
454  
455 A1: Yeah - yeah.  
456  
457 Q: Were you worried for anybody else's safety?  
458  
459 A1: I wasn't worried for my own at all. I wasn't worried for the neighbors or  
460 anything else like that. I - I just thought he might've gone into the woods by  
461 himself and went down to the creek and sat by the creek for a little while and  
462 came back home or something, after he'd, like, cooled down from his feelings.  
463  
464 Q: Okay. Then you heard four blasts, would you equate that with gunshots?  
465  
466 A1: Yes, completely with a gunshot, with a police - police gun.  
467  
468 Q: Okay.  
469  
470 A1: Yeah it sounded, like, kind of, like, .45.  
471  
472 Q: Okay did you go outside after you heard those?  
473  
474 A1: Uh, yeah, my stomach just dropped, and I felt really sick I was like no this is -  
475 then my neighbor ran outside that's when we started praying. My neighbor ran  
476 outside and she's like your friend might've just lost his life, and then I saw  
477 doggie (Ezekiel) he was goin' in the other direction going up the road then he  
478 - after the blast I went out and opened the door and the doggie was running  
479 without his leash.  
480  
481 Q: Okay and that was Jonathan's dog?  
482  
483 A1: Yeah.  
484  
485 Q: Did you bring him back in the house?  
486  
487 A1: No, I - me and, uh, (Kimberly) tried to walk through the neighborhood and  
488 yell (Ezekiel - Ezekiel)...  
489  
490 A: You tried to find him, right?  
491  
492 A1: The dog's name is (Ezekiel).  
493  
494 Q: Okay.  
495

496 A: 'Cause we'd like to help that dog, it's a really sweet dog.  
497  
498 A1: Yeah.  
499  
500 Q: Okay.  
501  
502 A1: Yeah for sure.  
503  
504 Q: Um, at this time I don't have anything further, Detective Ellis may have  
505 follow-up questions.  
506  
507 Q1: Um, Peter; correct?  
508  
509 A: Yes.  
510  
511 Q1: And then Joven?  
512  
513 A: Yes.  
514  
515 A1: Yeah.  
516  
517 Q1: Any of you guys - I know Joven you have a little more interaction with - with  
518 Johnny.  
519  
520 A: Yeah.  
521  
522 A1: Yeah.  
523  
524 Q1: As you refer to him, yours is very minimal.  
525  
526 A: Yeah.  
527  
528 Q1: Um, do either of you guys know what branch of the military he was in?  
529  
530 A1: Uh, infantry he said.  
531  
532 Q1: Would that be Army, Marine Corp, Navy?  
533  
534 A1: Army, I guess Army.  
535  
536 A: I'm not sure if he was in the Marine Corp or not.  
537  
538 A1: No, he wasn't in the Marines.  
539  
540 A: No.

541  
542 A1: He said he was in the Army, I believe.  
543  
544 A: And the what - didn't he make it to sergeant too, did you say?  
545  
546 A1: Yeah, he was a drill sergeant he said he made it to sergeant.  
547  
548 Q1: Okay.  
549  
550 A1: But he said he went in as, like, a lieutenant - what's the lowest rank?  
551  
552 A: Oh private, everyone goes in as private.  
553  
554 A1: Private.  
555  
556 A: Everyone goes in as private.  
557  
558 A1: Everyone goes in as private, but he came out a, uh, sergeant so.  
559  
560 Q1: And then I know he's talked to you about family before.  
561  
562 A1: Yeah, uh...  
563  
564 Q1: Like, children?  
565  
566 A1: Yeah ,uh, that's - that's kind of why I wanted to be his friend too because, you  
567 know, I- I just wanted to be - I just felt, like, you know, he was missing  
568 something and, you know, I went to his studio and hung out with him and.  
569  
570 Q1: Did - did he ever say where the wife and children are now?  
571  
572 A1: Um, no he actually never told, like, I tried to ask him a bit about it, but he was  
573 really unclear, like, whether his wife had left him for someone else or it, like,  
574 he basically told me they just disappeared.  
575  
576 A: He said they just disappeared.  
577  
578 A1: Yeah.  
579  
580 Q1: So, he doesn't have contact with them anymore that you're aware of?  
581  
582 A: He doesn't no, and apparently, he doesn't know how to get hold of them.  
583  
584 A1: No - no and then I think it's been three years...  
585

586 A: Oh sorry.  
587  
588 Q1: No - just for my recorder's sake try not to talk over. Go ahead Jo- or, uh,  
589 Peter. What were you saying?  
590  
591 A: Uh, and from what I hear he - he doesn't know how to find them they're -  
592 they're gone, he doesn't - doesn't know where they are.  
593  
594 Q1: So, there's no communication?  
595  
596 A: No communication.  
597  
598 A1: And they used to live in Israel together, so he thinks she might've gone to  
599 another country in the world.  
600  
601 Q1: Okay how about other family, like, uh, mom, dad, brothers?  
602  
603 A1: Um, he told me that he - he grew up in boy's homes all of his life and that he  
604 didn't have - well his mom and dad, like, his real mom and dad sold, uh, put  
605 him as a ward of the state. When he was about...  
606  
607 A: Eight.  
608  
609 A1: Eight to ten.  
610  
611 A: He was seven years old.  
612  
613 A1: Eight.  
614  
615 A: And he was in, uh, foster homes from age eight but he would run away  
616 anytime he could.  
617  
618 A1: And then he would meet with his brother, (Mark).  
619  
620 Q1: Did he say what state?  
621  
622 A1: Uh...  
623  
624 Q1: The ward of the state?  
625  
626 A1: New York.  
627  
628 Q1: New York maybe?  
629  
630 A: He has a New York accent that's for sure.



631  
632 A1: He said Rochester area.  
633  
634 Q1: So upstate?  
635  
636 A1: Yeah.  
637  
638 Q1: Okay but then you said the family that possibly in - in Israel that's - that's the  
639 wife and children?  
640  
641 A1: Yeah - yeah.  
642  
643 A: They were in Oregon, right?  
644  
645 A1: No, they were in Ohio. They were in the Columbus area.  
646  
647 A: Okay (unintelligible).  
648  
649 Q1: Okay. That's where his wife is originally from?  
650  
651 A1: Uh, I don't know - she's, uh, actually he said she - had Israeli blood, but I  
652 don't know if she was, like, half German and half Israeli.  
653  
654 Q1: Okay.  
655  
656 A1: Uh, but he met her through a friend from the service.  
657  
658 Q1: Okay and then he arrives, and he came over to your house...  
659  
660 A1: And he had four kids with her.  
661  
662 Q1: Four kids, all right.  
663  
664 A1: He had a daughter I believe and three sons.  
665  
666 Q1: He came to your house yesterday do you remember what time he got here?  
667  
668 A1: Mm, trying to think it was actually earlier on in the day. It's probably, like,  
669 before noon.  
670  
671 Q1: So, around lunch time?  
672  
673 A1: Yeah around lunch time and we spent the whole day together.  
674  
675 Q1: Was his behavior yesterday the same that it was this morning, before you

676 locked the door?  
677  
678 A1: No, um, actually yesterday he was, like, talking - well you know, he seemed  
679 to be talking about what he was doing, he was trying to get a new studio and  
680 trying to find a new spot and then the next morning he seemed, like, he was  
681 overcome. He seemed, like, he was having a nervous breakdown which I'm  
682 familiar 'cause I have really bad anxiety problems, depression problems.  
683  
684 Q1: Was - when you woke up this morning, was he already awake or was he still  
685 asleep?  
686  
687 A1: Um, he was, uh, he just got up - he just got up about the same time as me. He  
688 was, like, laying on the couch and I was in my bedroom.  
689  
690 Q1: And how was he acting this morning when you first got up?  
691  
692 A1: Uh, pretty relaxed. Just - just, uh, like, seemed a little more, like, he - he was  
693 telling me more about his wife and kids and more of, like, uh, just, like, how -  
694 how he - he used the term lost his stars. As, like, lost his wife and his kids and  
695 he's like, "A sky with no stars is a black night." Um...  
696  
697 Q1: What in like the - from the time that you guys woke up, do you remember  
698 what time that was by chance?  
699  
700 A1: Uh, 8:00 or 9:00.  
701  
702 Q1: So, from 9:00 to noon today what kind of change, what did you recognize  
703 anything different with his behavior.  
704  
705 A1: Well, uh, first we were, uh, playing a little bit of music so, uh, it seemed just  
706 kind of normal.  
707  
708 Q1: Mm-hm.  
709  
710 A1: And then he wanted to show me his wife's CD and then he told me she was a  
711 really beautiful singer and stuff. And he wasn't actually being, like - until  
712 after we're - after what happened I didn't even know what he was talking  
713 about. Like, he was saying that, you know what I mean, he was using  
714 terminology, like, he lost his stars and I wouldn't know what that meant.  
715  
716 Q1: So, when he started listening to the - the music of his wife, did his behavior  
717 start to change?  
718  
719 A1: Yeah I saw tears running down his face and he just started getting really sad,  
720 and I went over and gave him a hug and I said hey Johnny, I said I'm here for

721 you as a friend and I said, you know, like, you've got my back I've got yours.  
722

723 Q1: Okay and then how long after he was listening to the music did, he go outside  
724 and start doing the, uh, cadence out in the front yard?  
725

726 A1: Um, it took probably a couple hours. He was drinking a little bit of beer, like,  
727 uh, just a, uh, little can.  
728

729 Q1: Okay.  
730

731 A1: Um, but it wasn't, like - like, hard liquor or anything it wasn't - it wasn't, like,  
732 drunk but he seemed, like, kind of drunk. Like, he I don't know he seemed  
733 kind of...  
734

735 Q1: And then how did he get here yesterday?  
736

737 A1: Uh, he drove here.  
738

739 Q1: What kind of vehicle does he drive?  
740

741 A1: A Honda Ridgeline.  
742

743 Q1: What color is it?  
744

745 A1: Red.  
746

747 Q1: Is it the one that's still parked out front of your residence?  
748

749 A: Yes.  
750

751 A1: Yeah.  
752

753 Q1: Okay.  
754

755 A1: And then also too, uh, he's, like - when he left that's why I didn't understand  
756 until afterwards when he left and I locked the door he said that, um, like,  
757 father Christmas has gotta come and I've gotta, like, you're gonna see in a  
758 little while or something that's what I really worried about. 'Cause we'd  
759 known about his Portland thing that he'd done, and stuff and we knew that he  
760 was a little mentally unstable, definitely.  
761

762 A: At least yeah.  
763

764 A1: Uh, I mean he seemed like from the war and stuff all that, just he just seemed,  
765 like, he was a little damaged guy and he had, uh, physical injuries too. He had

766 spinal injuries.  
767  
768 A: Yeah, I guess he came back from...  
769  
770 A1: He got medevacked from Iraq.  
771  
772 A: Right paralyzed and they're going - going again so yeah, it's a major issues  
773 and...  
774  
775 A1: Yeah and he was just yeah he, like, right before he left he was, like, he was  
776 just talking, um, down to himself he was telling me, like, how fat he'd gotten  
777 and how, um, just - just broken he is 'cause he doesn't have his wife and kids  
778 and that's all that, you know, that was his whole foundation of his whole life.  
779  
780 Q1: Okay.  
781  
782 A1: So...  
783  
784 Q1: So, when you were back inside the residence, um, he was out doing the - the  
785 cadence out front.  
786  
787 A1: Yeah.  
788  
789 Q1: Um, you locked the door he ends up going away.  
790  
791 A1: Mm-hm.  
792  
793 Q1: You hear the gunshots.  
794  
795 A1: Then I open the door.  
796  
797 Q1: Correct.  
798  
799 A1: Go outside.  
800  
801 Q1: Um, and then at some point did you go back in your house?  
802  
803 A1: Yeah, I felt a little sick actually because just, you know, my stomach just  
804 dropped and I was like oh no.  
805  
806 Q1: Did...  
807  
808 A1: Because I was afraid of that too because just, he'd given me hints all along  
809 and I didn't - I didn't take them...  
810

811 A: (Unintelligible) hints till after it happened yeah.  
812  
813 A1: ...until after it happened.  
814  
815 Q1: Okay.  
816  
817 A1: And then - and then I understood that he was actually trying to, like, tell me  
818 what he was doing and then he wanted me to shave my beard and my hair  
819 yesterday. And I just decided to do, like, a buzz, you know, cut off and then  
820 shave my beard off. And I didn't realize that he was, like, wanting to - he said,  
821 uh, God has a - God has a plan for you and he wants you to, like, look clean so  
822 you can go get work and...  
823  
824 Q1: Okay.  
825  
826 A1: So, I just shaved my - yeah - I just shaved my beard off and cut my hair  
827 shorter and...  
828  
829 A: He's actually really encouraging towards you.  
830  
831 A1: Yeah - yeah and he was all - the only - well I haven't had any friends since  
832 I've lived here for the three years I've lived here and I've been really weary  
833 and apprehensive, uh, of the friends I've picked just because people aren't  
834 nice these days a lot of kids aren't, and just people aren't trustworthy.  
835  
836 Q1: When you went back inside the house, um, after the interaction with the police  
837 department occurred, did you see if he left anything in your house? Is there  
838 anything still inside your guys' residence of his?  
839  
840 A1: Um, his, uh, helmet bag.  
841  
842 Q1: Helmet bag? Like a motorcycle helmet or?  
843  
844 A1: Like a - like a army helmet thing.  
845  
846 Q1: Okay.  
847  
848 A1: Um, but, uh...  
849  
850 Q1: And he slept on the couch last night?  
851  
852 A1: Yeah.  
853  
854 Q1: Um, obviously he probably used your guys' restroom, too right?  
855

856 A1: Yeah.  
857  
858 Q1: Is there anywhere - anywhere else in the house where that he might've had  
859 access to that he left something?  
860  
861 A: Um, no I wasn't here but y- pretty much it's the front room and bathroom.  
862  
863 A1: Yeah, he only used the front room and bathroom and then we went out and  
864 drove for part of the day yesterday.  
865  
866 Q1: Okay, um, was anybody at your house with you when- when Johnny was there  
867 with you?  
868  
869 A1: No.  
870  
871 Q1: Okay.  
872  
873 A1: It's just me and Johnny. My dad said he'd be home in about an hour or so  
874 before this happened. So, then I just told Johnny I said oh my dad's gonna be  
875 home soon you wanna give him some space and go for a ride? And then that's  
876 when he started doing the cadence and acting, like, really weird and I'm like  
877 let's go for a ride man, you know what I mean, I'm just trying to be, uh,  
878 supportive of him and not but not get into his face too. Where it's, like, yeah, I  
879 was just trying to be a friend.  
880  
881 Q1: You guys said the studio was called "Steady Rhythms?"  
882  
883 A1: Yeah.  
884  
885 Q1: And that was off of Contractor?  
886  
887 A1: Mm-hm.  
888  
889 Q1: That's over by Basha's correct?  
890  
891 A: Yes.  
892  
893 A1: Yes.  
894  
895 Q1: Do you know if - and he got evicted yesterday?  
896  
897 A1: No, uh, he, uh, was - the guy that was evicting him was letting him take his  
898 time and he took over the course of at least a week just to pack up all of his  
899 stuff and...  
900

901 Q1: And what kind of studio was that? A music studio?  
902  
903 A1: Yeah it was a, um, I don't know how you explain it just, like, a computer  
904 music studio. It was, like, with, you know, a PA system and...  
905  
906 Q1: So, it wasn't, like, an art studio where you paint and...  
907  
908 A1: No - no.  
909  
910 Q1: So, it was more music driven?  
911  
912 A1: It was a music studio yeah and it was called War Factor Studios named after  
913 his brother (Mark).  
914  
915 Q1: War Factor Studios or Steady Rhythms?  
916  
917 A1: But he called it - he called his side War Factor Studios. Because he was  
918 renting half of it.  
919  
920 Q1: War Factor Studios.  
921  
922 A1: Yeah.  
923  
924 Q1: Do you know who the - the other gentleman was? Does he give a name or  
925 anything?  
926  
927 A1: Who?  
928  
929 Q1: Did Johnny ever say that the gentleman's name, the landlord?  
930  
931 A1: Uh, I believe his name's Dan.  
932  
933 Q1: Last name by chance?  
934  
935 A1: Nah I don't know; I don't know him very well I don't...  
936  
937 Q1: Did you ever meet Dan?  
938  
939 A1: Yeah, I've met Dan he, uh, has another side of the studi- like, they rented it  
940 half and half and he has another side where he sells books and makes drums.  
941  
942 Q1: Okay do you have a phone number for Dan?  
943  
944 A1: Uh, actually I don't.  
945

946 Q1: Okay. So, I know that Detective Ruble had asked you, um, if you could hear  
947 things from inside your residence you said that you could hear him doing the  
948 cadence.  
949

950 A1: Yeah.  
951

952 Q1: And then when the - the police car drove by...  
953

954 A1: After he - after it drove by I, uh, you know, I was kind of sitting in between  
955 my room and the chair and then my bed.  
956

957 Q1: Okay.  
958

959 A1: And then, um, after he yeah, he started doing - well no after the police car  
960 came he, uh, I heard, like, I heard them yelling at him. I don't know quite I  
961 think they said put the weapon down.  
962

963 Q1: Okay.  
964

965 A1: Like, and that - that's what was going through my head anyway. Because I  
966 said, "Dude, you can't carry around a sword in my neighborhood. It's, like,  
967 nah, you know, just normal people don't carry around a sword in the  
968 neighborhood, you know, it's, like, I'm just a little uncomfortable with it."  
969

970 Q1: Okay. Could you see from your house the interaction with the police  
971 department and John?  
972

973 A1: I just saw the dog run by came out, like, you know, from around the corner, no  
974 I didn't see the interaction and I...  
975

976 Q1: Okay.  
977

978 A1: I kind of didn't want to.  
979

980 Q1: Okay.  
981

982 A1: 'Cause I was really emotionally distraught, crying and...  
983

984 Q1: No that's all right, I just didn't know if you could see from your - your  
985 vantage point. Um, there's one thing you said that I was gonna follow-up on,  
986 go John.  
987

988 Q: One quick question, you said he had a brother by the name of (Mark)?  
989

990 A1: Mm-hm.



991  
992 Q: Do you know where (Mark) lives?  
993  
994 A1: Uh, he said (Mark)'s incarcerated in I believe Kentucky. Um, because he  
995 started this, uh, well see Johnny started this company, um, the private security  
996 company, um, after 9/11 and he was from New York and him and his brother  
997 Nark - (Mark) started this. And he just had a really it seemed like a really  
998 close relationship with (Mark). And he said (Mark) was supposed to be  
999 getting out of prison soon and he said that (Mark) gave a, uh, had some kind  
1000 of stamp that you put on a paperwork, um, for I - I don't know what kind of  
1001 paperwork but for his security agency to make it official or make it licensed.  
1002 And he put on a bad stamp.  
1003  
1004 Q: Okay and that's why his brother (Mark) is incarcerated in Kentucky?  
1005  
1006 A1, Yeah.  
1007  
1008 Q: To your knowledge?  
1009  
1010 A1: Yeah to my knowledge that's what he's, you know, I didn't go into too much  
1011 detail.  
1012  
1013 Q: Do you know when that was?  
1014  
1015 A1: I don't know when it as, but he said he's supposed to be getting out soon.  
1016  
1017 Q: Okay any other relatives? You don't know where his mom or his dad are  
1018 because he'd been in foster homes, um, since he was 8. Do you know what  
1019 foster home he was in? Did he ever talk about that/ Was it here in Arizona?  
1020  
1021 A: No, I don't - I don't know (unintelligible).  
1022  
1023 A1: He told me that it said upstate New York, Rochester area. He said that that's  
1024 where he grew up most of his life. Um, which that's one thing we had in  
1025 common 'cause I'm from Ohio so.  
1026  
1027 Q: I don't have anything further. Detective Ellis do you have anything?  
1028  
1029 Q1: Uh, do you know if (Mark) has the same last name?  
1030  
1031 A1: Uh, no.  
1032  
1033 Q1: Okay.  
1034  
1035 A1: But I - I did know, uh, that they, uh, they had, like, Messare spelled

1036 backwards on their arm maybe, I think they both had that. I don't know  
1037 though.  
1038  
1039 A: Like, (unintelligible) tattoos?  
1040  
1041 A1: Yeah, it's pictures yeah and it's just his name spelled backwards. It's Messare  
1042 instead of - what? No wait. Erassem it's just spelled this backwards.  
1043  
1044 Q1: E-R-A-S-S-E-M backwards.  
1045  
1046 A1: Yeah.  
1047  
1048 Q: Right.  
1049  
1050 A1: And he had this on one arm and then he had legend on the other.  
1051  
1052 Q: So, you pointed to your right arm so that's where he had his name tattooed  
1053 backwards on his right arm?  
1054  
1055 A1: I don't know if it's right or left...  
1056  
1057 Q: Okay.  
1058  
1059 A1: ...to be honest, to remember.  
1060  
1061 Q: Okay that's fine. But you know his brother and him both have them?  
1062  
1063 A1: I - I believe they did yeah...  
1064  
1065 A: That's what he told you right?  
1066  
1067 A1: 'Cause I believe that was their thing, yeah.  
1068  
1069 Q: Okay.  
1070  
1071 Q1: Uh, Joven do you have social media?  
1072  
1073 A1: Um, yeah, I mean...  
1074  
1075 Q1: Facebook, Twitter?  
1076  
1077 A1: Uh, yeah, I do.  
1078  
1079 Q1: Do you know if he did?  
1080

1081 A1: Uh, yeah but he apparently got rid of it or something he said or it's, like, in the  
1082 process of his account, like, so I didn't...  
1083  
1084 Q1: What kind of social media di- was it, uh, Instagram, Facebook, Twitter?  
1085  
1086 A1: Um, he had, uh, Facebook.  
1087  
1088 Q1: Facebook?  
1089  
1090 A1: Yeah.  
1091  
1092 Q1: Okay.  
1093  
1094 A1: Yeah.  
1095  
1096 Q1: Were you guys friends on Facebook?  
1097  
1098 A1: Yeah. And, uh, he would go and send me a lot of his writings on Facebook.  
1099 He would make me think too that he was a little bit of, uh, mentally, you  
1100 know, just unstable with his writings.  
1101  
1102 Q: Is his phone at your house or did he take it with him?  
1103  
1104 A1: Uh, his phone is at my house.  
1105  
1106 Q: It is at your house, is it on - in the bag or on a table do you know exactly  
1107 where the phone is to your recollection?  
1108  
1109 A1: Uh no. I don't know exactly where but...  
1110  
1111 Q: Do you know what kind of phone it is?  
1112  
1113 A1: No.  
1114  
1115 Q: Do you know the color?  
1116  
1117 A1: It's not a new phone it's just kind of like a little smart phone.  
1118  
1119 Q1: Is it a flip phone or a smartphone?  
1120  
1121 A1: It's like a touchscreen phone but then maybe, like, you'd call it a tough phone.  
1122 It seems like one of those ones that you can drop a lot.  
1123  
1124 Q: Do you have your phone with you?  
1125

1126 A1: Uh yeah, I think.  
1127  
1128 Q: Okay - okay could you check please if you have it? Could you check to see if  
1129 you have it because...  
1130  
1131 A1: No, I don't actually.  
1132  
1133 Q: Okay where would you have left your phone?  
1134  
1135 A1: Probably in my vehicle.  
1136  
1137 A: Probably in the truck that we just drove back down.  
1138  
1139 Q: Oh, okay so yours would be in there. What kind of phone do you have?  
1140  
1141 A1: I have some kind of Motorola, like, cheap android.  
1142  
1143 Q: And - and Peter...  
1144  
1145 A: Yes.  
1146  
1147 Q, ...do you have a phone too?  
1148  
1149 A: Yes.  
1150  
1151 Q: Is it with you?  
1152  
1153 A: Uh, no it's in my truck.  
1154  
1155 Q: It's in your truck what kind do you have?  
1156  
1157 A: Uh, I have exactly the same as what he has, I got two cheap ones.  
1158  
1159 Q: Okay so no other phones or anything like that in the house that belong to you?  
1160  
1161 A: No.  
1162  
1163 Q: Okay so you believe that he - that your friend Johnny had a touch tone type  
1164 phone.  
1165  
1166 Q1: Touchscreen.  
1167  
1168 Q: Touchscreen.  
1169  
1170 A1: Yeah.

1171  
1172 Q: Do you know what color it was. I think I might've asked...  
1173  
1174 A1: It was black, or I don't know grey, black or grey.  
1175  
1176 Q1: Do you have his number?  
1177  
1178 A1: Uh, he just, like, went off some kind of app.  
1179  
1180 Q1: He used an app?  
1181  
1182 A1: Yeah, he used an app yeah, he didn't have - he had to use Wi-Fi to call me.  
1183  
1184 Q1: Okay did it come across as a phone number though? When he called?  
1185  
1186 A1: Yeah - yeah it was the same phone number I saved it as (unintelligible) text  
1187 app.  
1188  
1189 Q1: Okay do you mind if we get that phone number from you?  
1190  
1191 A1: Uh...  
1192  
1193 Q1: We'll get it when we get back to your truck for you. Anything else John? Is  
1194 there anything else gentleman that we haven't touched about or haven't talked  
1195 about in the interview that you think is pertinent to the...  
1196  
1197 A1: Um, just, like, I was gonna add in that lately though he had been sending me a  
1198 lot of these long running messages about, like, kind of, like, poems about just  
1199 his life and stuff and I thought it was his, uh, like, his artwork, you know, his  
1200 music artwork. So, you know, but a lot of it was - seemed touchy and, like,  
1201 sad. So, then he sent me these long running...  
1202  
1203 Q1: How would he send that to you?  
1204  
1205 A1: Um...  
1206  
1207 Q1: Text message, Facebook?  
1208  
1209 A1: Text.  
1210  
1211 Q1: Text message?  
1212  
1213 A1: Yeah.  
1214  
1215 Q1: Jovan do you have an - I did write something else down that I forgot to touch

1216 up with you.  
1217  
1218 A1: Mm-hm.  
1219  
1220 Q1: Um, you said that he got in a fight with the police department in Portland, is  
1221 that correct?  
1222  
1223 A1: Yeah there was a video on YouTube and that's what I'd seen him, and he was  
1224 running through apparently a middle school or some kind of school naked.  
1225 And, uh, he just had his hatchet on and then he took it off and then he ended  
1226 up getting incarcerated over in Oregon.  
1227  
1228 Q1: Do you remember...  
1229  
1230 A1: And they beat him up and they said they beat him brutally. And just, like, the  
1231 way he talked about it he had very extreme emotion and cried so I believe  
1232 they really - yeah, the police, like, beat him up there...  
1233  
1234 Q1: Do you remember, uh, what year the actual incident happened?  
1235  
1236 A1: No, he wasn't, you know, very specific about it 'cause he said he had a brain  
1237 injury and his - his, like, recollection of years wasn't very.  
1238  
1239 Q1: Okay.  
1240  
1241 A1: And he said he had a spine injury and a brain injury from apparently Walter  
1242 Reed, like, from getting medevacked from Iraq.  
1243  
1244 Q1: And when he showed you the video on YouTube, how did - do you know how  
1245 he found it did he just type his name in? Portland, Oregon?  
1246  
1247 A1: Uh, War Factor Studios on YouTube, wait not - not that one actually the video  
1248 of him in...  
1249  
1250 Q1: In the - in the school.  
1251  
1252 A1: It said just man with hatchet, like, the video is called man with hatchet runs  
1253 through...  
1254  
1255 A: It was on the news, too right?  
1256  
1257 A1: Yeah, it's called man with hatchet runs through, like, parking lot in Portland.  
1258  
1259 Q1: Okay.  
1260

1261 A1: And I found that - that way on YouTube.  
1262  
1263 Q1: Something similar to that effect.  
1264  
1265 A1: Yeah and it was just a news report of him doing it.  
1266  
1267 Q1: Gotcha. What did he - how did he describe that incident to you, like, did he,  
1268 uh...  
1269  
1270 A1: He seemed really emotional and sad about it and he said that the police had,  
1271 like, brutally beat him afterwards and he was just trying to help people.  
1272  
1273 Q1: Did he ever say to you when he - when his wife and children disappeared?  
1274  
1275 A1: Uh, he said it's been, like, about three years, I think.  
1276  
1277 Q1: About three years.  
1278  
1279 A1: Yeah.  
1280  
1281 Q1: And Peter question for you.  
1282  
1283 A: Yes.  
1284  
1285 Q1: How - how long ago did you meet - actually meet him in person?  
1286  
1287 A: I first met him in person - I'm just trying to think...  
1288  
1289 A1: Probably just a couple nights after - after I met him.  
1290  
1291 A: Only - only weeks ago, like, two or three weeks ago maybe.  
1292  
1293 A1: Mm-hm.  
1294  
1295 A: Less than a month probably.  
1296  
1297 Q1: And how many interactions have you had?  
1298  
1299 A: Uh, I've - been over when sh- took Joven over to the studio a couple times  
1300 just to drop him off or to pick him up. Uh, so, uh, probably half a dozen.  
1301  
1302 Q1: Okay.  
1303  
1304 A: I think maybe six interactions.  
1305

1306 Q1: All right.  
1307  
1308 A: I mean we went over and helped jump, you know, the flat battery, went over  
1309 to the truck and give him a jump start, Joven's friends, you know.  
1310  
1311 A1: Yeah and he - just the whole time I've known him he's seen obviously not, he  
1312 seemed, like, he was missing something, or he was a little, not missing  
1313 something just - just I guess a brain injury. I don't know what a brain injury  
1314 consists of.  
1315  
1316 Q1: Okay and then Joven this morning when he was doing the - the cadence and  
1317 the stuff out front, um, was that out of character for him?  
1318  
1319 A1: Yeah well, like, it just seemed, like, he'd never done anything like that around  
1320 me.  
1321  
1322 Q1: Around you.  
1323  
1324 A1: He'd never done cadence or anything like that he was always just hanging out.  
1325  
1326 Q1: Did you try talking to him when he was doing the cadence?  
1327  
1328 A1: Yeah, I just tried to say hey cool it down Johnny you're being a little loud in  
1329 my neighborhood and you're walking around with a sword and you're not a -  
1330 bother people you know what I mean. You're being and he's just he wouldn't  
1331 listen to me he just kept doing it.  
1332  
1333 Q1: So, he wasn't responding to you?  
1334  
1335 A1: No.  
1336  
1337 Q1: Okay. Did it look like he was - did he look - make eye contact with you or  
1338 look at you when you were talking?  
1339  
1340 A1: Uh, no well he did, like, a little bit, like, he'd lo- glance at me but then he'd  
1341 continue doing it and saying - so then I thought it was kind of rude so then I  
1342 just left, like, went and locked the door.  
1343  
1344 Q1: So, from my understanding, um, for lack of better term did it seem, like, he  
1345 was zoned out or in the - in, like, a deep state of focus on the cadence?  
1346  
1347 A1: Um...  
1348  
1349 Q1: Would that be a fair assumption? No?  
1350



1351 A1: No - no he's just, like, just, like, doing what a drill sergeant would do. I don't  
1352 know just doing a chant and, like, doing, like, moving...

1353  
1354 Q1: Okay.

1355  
1356 A1: So.

1357  
1358 Q: I don't have any further questions. If you have nothing further gentlemen,  
1359 we're gonna stop the tape at 2008 hours.

1360  
1361  
1362 The transcript has been reviewed with the audio recording submitted and it is an accurate  
1363 transcription.

1364 Signed, John D. Ruble, #5627, January 30, 2020



# **ARIZONA DEPARTMENT OF PUBLIC SAFETY**

## **V. SUPPORTIVE DOCUMENTS**

**DR NUMBER:**

**I20003903**

1. Weather Underground Report
2. Crime Scene Measurements and Diagram
3. Incident Command Log (ICS) and Documents
4. Sedona Police Department CAD/911 Logs
5. Sedona Fire District CAD Log
6. Search Warrants Returns and Receipts
7. Collected Evidence Logs
8. Chain of Custody Forms
9. Non-Collected Evidence Logs
10. Sedona Police Department Officer Safety Bulletin
11. Firearm Function Test Report
12. Field Drug Test Report
13. AZDPS Supplements
14. Messare's Facebook Messages
15. Coconino County Medical Examiner's Autopsy Report
16. Witness Statements
17. Victim's Rights Forms
18. AZDPS Cellular Phone Examination Request Form

<b>Detective Name</b>	<b>ID No.</b>	<b>Location</b>	<b>Date</b>	<b>Supervisor</b>
Andrew Reed	7325	31030100	01/22/2020	Sergeant Matthew Monaco, #6645

# Summary

Temperature (° F)	Actual	Historic Avg.	Record	▲
High Temp	66	67	81	
Low Temp	57	44	34	
Day Average Temp	61.35	56	-	
Precipitation (Inches)	Actual	Historic Avg.	Record	▲
Precipitation (past 24 hours from 07:15:00)	0.00	0.03	-	
Dew Point (° F)	Actual	Historic Avg.	Record	▲
Dew Point	24.69	-	-	
High	32	-	-	
Low	21	-	-	
Average	24.69	-	-	
Wind (MPH)	Actual	Historic Avg.	Record	▲
Max Wind Speed	22	-	-	
Visibility	20	-	-	
Sea Level Pressure (Hg)	Actual	Historic Avg.	Record	▲
Sea Level Pressure	29.39	-	-	
Astronomy	Day Length	Rise	Set	▲
Actual Time	10h 9m	7:45 AM	5:54 PM	
Civil Twilight		7:18 AM	6:22 PM	
Nautical Twilight		6:47 AM	6:53 PM	
Astronomical Twilight		6:17 AM	7:23 PM	
Moon: waning crescent		3:59 AM	2:25 PM	

January

20

2020

View

Daily Weekly Monthly

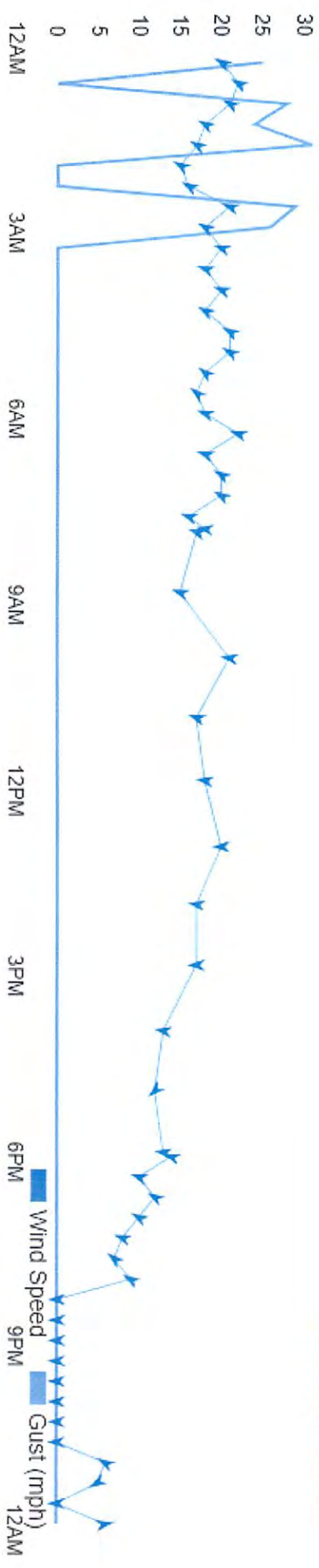
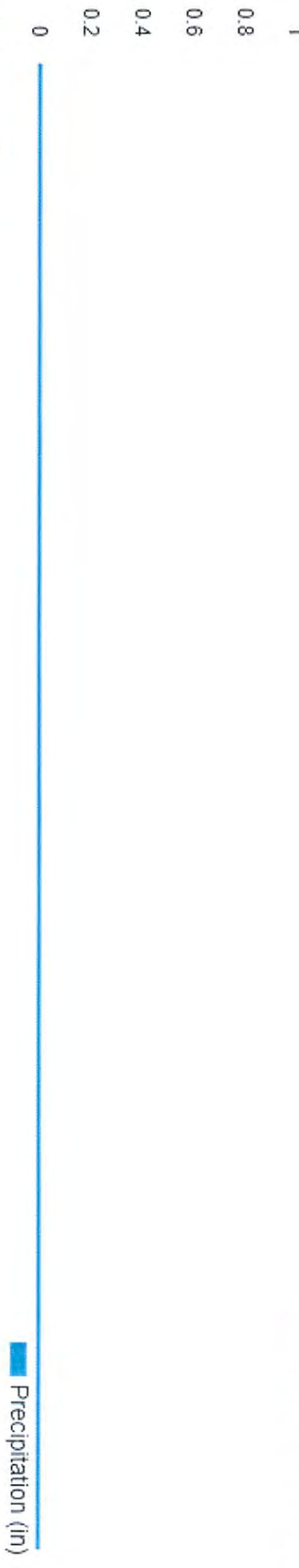
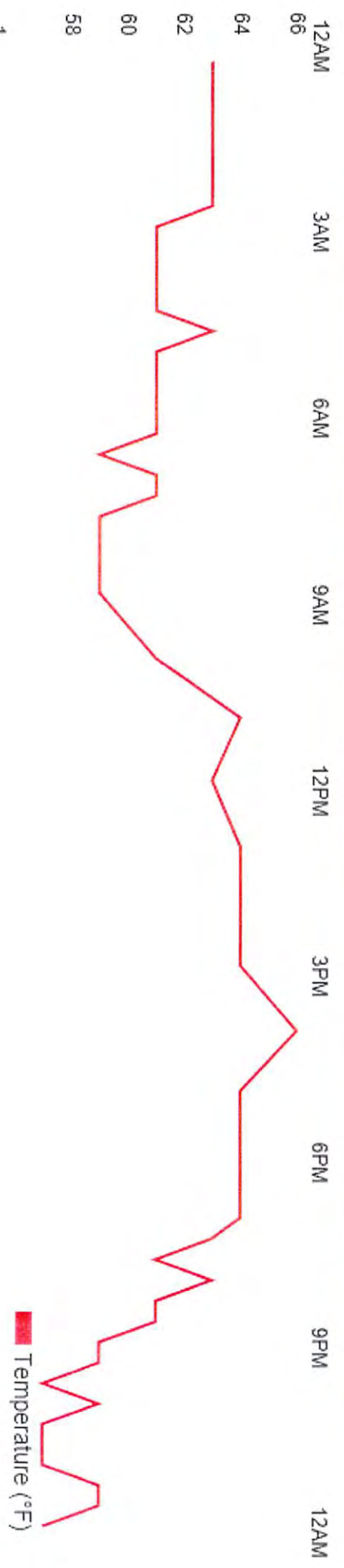

# Daily Observations

Time	Temperature	Dew Point	Humidity	Wind	Wind Speed	Wind Gust	Pressure	Precip.	Condition
12:15 AM	63 °F	23 °F	22 %	NNE	20 mph	25 mph	29.37 in	0.0 in	Cloudy
12:35 AM	63 °F	23 °F	22 %	NNE	22 mph	0 mph	29.37 in	0.0 in	Cloudy / Windy
12:55 AM	63 °F	23 °F	22 %	NNE	21 mph	28 mph	29.36 in	0.0 in	Fair / Windy
1:15 AM	63 °F	23 °F	22 %	NNE	18 mph	24 mph	29.37 in	0.0 in	Fair
1:35 AM	63 °F	23 °F	22 %	NNE	17 mph	31 mph	29.36 in	0.0 in	Fair
1:55 AM	63 °F	25 °F	24 %	NNE	15 mph	0 mph	29.36 in	0.0 in	Fair
2:15 AM	63 °F	23 °F	22 %	NNE	16 mph	0 mph	29.37 in	0.0 in	Fair
2:35 AM	63 °F	23 °F	22 %	NNE	21 mph	29 mph	29.35 in	0.0 in	Fair / Windy
2:55 AM	61 °F	23 °F	23 %	NNE	18 mph	26 mph	29.35 in	0.0 in	Cloudy
3:15 AM	61 °F	23 °F	23 %	NNE	20 mph	0 mph	29.35 in	0.0 in	Cloudy
3:35 AM	61 °F	23 °F	23 %	NNE	18 mph	0 mph	29.35 in	0.0 in	Cloudy
3:55 AM	61 °F	23 °F	23 %	NNE	20 mph	0 mph	29.34 in	0.0 in	Fair
4:15 AM	61 °F	23 °F	23 %	NNE	18 mph	0 mph	29.35 in	0.0 in	Fair
4:35 AM	63 °F	23 °F	22 %	NNE	21 mph	0 mph	29.34 in	0.0 in	Fair / Windy
4:55 AM	61 °F	21 °F	22 %	NNE	21 mph	0 mph	29.35 in	0.0 in	Fair / Windy
5:15 AM	61 °F	23 °F	23 %	NE	18 mph	0 mph	29.35 in	0.0 in	Fair
5:35 AM	61 °F	23 °F	23 %	NE	17 mph	0 mph	29.35 in	0.0 in	Fair
5:55 AM	61 °F	23 °F	23 %	NNE	18 mph	0 mph	29.35 in	0.0 in	Fair
6:15 AM	61 °F	23 °F	23 %	NNE	22 mph	0 mph	29.33 in	0.0 in	Fair / Windy
6:35 AM	59 °F	23 °F	25 %	NNE	18 mph	0 mph	29.35 in	0.0 in	Fair
6:55 AM	61 °F	23 °F	23 %	NNE	20 mph	0 mph	29.35 in	0.0 in	Mostly Cloudy
7:15 AM	61 °F	21 °F	22 %	NNE	20 mph	0 mph	29.35 in	0.0 in	Mostly Cloudy
7:35 AM	59 °F	23 °F	25 %	NNE	16 mph	0 mph	29.36 in	0.0 in	Mostly Cloudy
7:47 AM	59 °F	23 °F	25 %	N	18 mph	0 mph	29.36 in	0.0 in	Cloudy

DPS000245

7:50 AM	59 °F	23 °F	25 %	NINE	17 mph	0 mph	29.36 in	0.0 in	Cloudy
8:48 AM	59 °F	23 °F	25 %	NNE	15 mph	0 mph	29.37 in	0.0 in	Cloudy
9:52 AM	61 °F	23 °F	23 %	N	21 mph	0 mph	29.36 in	0.0 in	Cloudy / Windy
10:50 AM	64 °F	23 °F	21 %	NNE	17 mph	0 mph	29.39 in	0.0 in	Cloudy
11:51 AM	63 °F	23 °F	22 %	N	18 mph	0 mph	29.37 in	0.0 in	Cloudy
12:55 PM	64 °F	25 °F	22 %	N	20 mph	0 mph	29.33 in	0.0 in	Cloudy
1:51 PM	64 °F	23 °F	21 %	N	17 mph	0 mph	29.30 in	0.0 in	Cloudy
2:50 PM	64 °F	23 °F	21 %	N	17 mph	0 mph	29.30 in	0.0 in	Cloudy
3:53 PM	66 °F	23 °F	19 %	N	13 mph	0 mph	29.29 in	0.0 in	Cloudy
4:51 PM	64 °F	27 °F	24 %	NW	12 mph	0 mph	29.26 in	0.0 in	Cloudy
5:51 PM	64 °F	23 °F	21 %	N	13 mph	0 mph	29.26 in	0.0 in	Cloudy
5:55 PM	64 °F	23 °F	21 %	NNE	14 mph	0 mph	29.25 in	0.0 in	Cloudy
6:15 PM	64 °F	25 °F	22 %	NNE	10 mph	0 mph	29.26 in	0.0 in	Cloudy
6:35 PM	64 °F	25 °F	22 %	NNE	12 mph	0 mph	29.28 in	0.0 in	Cloudy
6:55 PM	64 °F	25 °F	22 %	NNE	10 mph	0 mph	29.27 in	0.0 in	Cloudy
7:15 PM	63 °F	25 °F	24 %	NNE	8 mph	0 mph	29.27 in	0.0 in	Cloudy
7:35 PM	61 °F	27 °F	27 %	NE	7 mph	0 mph	29.27 in	0.0 in	Cloudy
7:55 PM	63 °F	25 °F	24 %	NNE	9 mph	0 mph	29.27 in	0.0 in	Fair
8:15 PM	61 °F	25 °F	25 %	CALM	0 mph	0 mph	29.28 in	0.0 in	Fair
8:35 PM	61 °F	27 °F	27 %	CALM	0 mph	0 mph	29.28 in	0.0 in	Fair
8:55 PM	59 °F	27 °F	29 %	CALM	0 mph	0 mph	29.28 in	0.0 in	Fair
9:15 PM	59 °F	30 °F	34 %	CALM	0 mph	0 mph	29.29 in	0.0 in	Fair
9:35 PM	57 °F	28 °F	33 %	CALM	0 mph	0 mph	29.29 in	0.0 in	Fair
9:55 PM	59 °F	28 °F	31 %	CALM	0 mph	0 mph	29.29 in	0.0 in	Fair
10:15 PM	57 °F	30 °F	36 %	CALM	0 mph	0 mph	29.29 in	0.0 in	Fair
10:35 PM	57 °F	30 °F	36 %	CALM	0 mph	0 mph	29.28 in	0.0 in	Mostly Cloudy
10:55 PM	57 °F	30 °F	36 %	NNE	6 mph	0 mph	29.27 in	0.0 in	Cloudy
11:15 PM	59 °F	30 °F	34 %	NNW	5 mph	0 mph	29.28 in	0.0 in	Cloudy

REPORT ID.				AGENCY REPORT NUMBER
YEAR MONTH DAY	HOUR	NCIC NO.	OFFICER ID NO	I20003903
20/01/20	1332	0799	7325	
<b>DIAGRAM LEGEND</b>				

Point	Y-Axis	X-Axis	Z-Axis	Description
-------	--------	--------	--------	-------------

1	0	0	0	RP1
2	16.957	14.505	0.079	SCALE
3	27.795	31.279	-0.006	SCALE
4	24.707	13.298	-0.037	ISLAND
5	28.041	22.612	0.221	ISLAND
6	35.415	30.631	0.399	ISLAND
7	42.22	37.825	0.409	ISLAND
8	61.565	54.895	1.001	ISLAND
9	70.294	58.434	1.242	ISLAND
10	76.991	53.235	1.262	ISLAND
11	68.688	42.139	1.267	ISLAND
12	54.588	28.583	0.907	ISLAND
13	26.418	8.193	1.954	ISLAND
14	32.436	5.718	-0.122	ISLAND
15	136.704	53.665	1.427	WALL
16	128.141	35.195	1.549	WALL
17	115.418	5.135	1.156	WALL
18	106.767	-1.564	1.008	EVD 11
19	102.063	-3.272	1.043	EVD 11
20	100.228	-3.057	1.242	EVD 10
21	98.624	-4.46	1.297	EVD 9
22	100.845	1.053	1.842	HEAD
23	94.573	2.543	1.847	FEET
24	89.376	7.987	1.034	EVD 8 & EVD G
25	77.52	18.622	1.086	ISLAND
26	70.144	7.36	0.761	ISLAND
27	60.465	0.943	0.633	ISLAND
28	59.176	10.55	0.845	ISLAND
29	66.552	22.834	1.328	ISLAND
30	36.276	2.48	0.307	SPD14, LEFT REAR
31	45.004	5.94	0.804	SPD14, LEFT FRONT
32	47.177	-0.429	0.914	SPD14, RIGHT FRONT
33	38.405	-3.819	0.815	SPD14, RIGHT REAR
34	49.56	-11.432	0.743	SPD7, LEFT REAR
35	56.706	-17.87	0.822	SPD7, LEFT FRONT
36	52.047	-22.556	0.643	SPD7, RIGHT FRONT

REPORT ID.				AGENCY REPORT NUMBER
YEAR MONTH DAY	HOUR	NCIC NO.	OFFICER ID NO	I20003903
20/01/20	1332	0799	7325	
<b>DIAGRAM LEGEND</b>				

Point	Y-Axis	X-Axis	Z-Axis	Description
-------	--------	--------	--------	-------------

37	45.119	-16.361	0.866	SPD7, RIGHT REAR
38	69.194	-4.942	0.516	SPD15, LEFT REAR
39	78.66	-4.555	0.557	SPD15, LEFT FRONT
40	78.842	-11.217	0.053	SPD15, RIGHT FRONT
41	69.561	-11.474	0.608	SPD15, RIGHT REAR
42	34.385	-4.818	-0.28	EVD 1
43	56.61	-10.767	0.386	EVD2 OFFSET 13
44	58.474	-8.241	1.452	EVD2 OFFSET 10
45	54.81	-6.098	-1.445	EVD3 OFFSET 13
46	57.738	-5.298	0	EVD3 OFFSET 10
47	66.919	1.211	0	EVD 4
48	61.559	-10.537	0	EVD5 OFFST 15
49	63.367	-6.969	0	EVD5 OFFST 11
50	71.56	-0.38	0	EVD 6
51	70.035	5.718	0	EVD 7
52	77.884	3.461	-0.315	ORANGE CONE
53	73.296	-3.157	-0.096	GREEN CONE
54	91.113	-1.098	0.688	EVD D
55	92.285	-0.263	0.781	EVD E
56	97.231	-2.101	0.981	EVD F
57	77.54	-16.598	0.469	YELLOW CONE
58	58.863	-40.2	0.451	FENCE
59	37.28	-29.458	0.615	FENCE
60	25.492	-25.504	0.187	FENCE
61	23.107	-23.457	0.105	ISLAND
62	32.541	-18.412	1.29	ISLAND
63	35.664	-22.843	1.754	ISLAND
64	24.021	-18.822	0.911	ISLAND
65	-129.104	120.916	10.46	OR / 367BZR, LEFT REAR
66	-127.449	111.114	9.971	OR / 367BZR, LEFT FRONT
67	-133.98	109.797	9.727	OR / 367BZR, RIGHT FRONT
68	-135.375	119.905	10.176	OR / 367BZR, RIGHT REAR
69	-100.037	143.784	8.519	ROAD
70	-101.525	162.717	9.828	ROAD
71	-60.623	41.305	-3.563	ROAD
72	-67.671	34.155	-3.587	ROAD



REPORT ID.				AGENCY REPORT NUMBER
YEAR MONTH DAY	HOUR	NCIC NO.	OFFICER ID NO	I20003903
20/01/20	1332	0799	7325	
<b>DIAGRAM LEGEND</b>				

Point	Y-Axis	X-Axis	Z-Axis	Description
-------	--------	--------	--------	-------------

73	-47.708	18.174	-5.497	ROAD
74	108.918	-17.824	0.733	WALL
75	76.929	-31.094	0.465	TRAILER
76	81.623	-27.974	0.508	TRAILER
77	-9.402	-15.024	-10.522	CONCRETE DRIVE
78	64.339	-0.25	0	EVD 2
79	68.338	2.844	0	EVD 5
80	67.395	-2.702	0	EVD 3
LP	0	0	0	Reference Point
base	5.941	8.923	-1.676	

ARIZONA DEPARTMENT OF PUBLIC SAFETY  
VEHICULAR CRIMES UNIT

DATE	TIME	NCIC	OFFICER'S ID	REPORT NUMBER
2020/01/20	1332	0799	7325	I20003903

MEASURED AND DRAWN BY DETECTIVE D. SORTOR, #6400

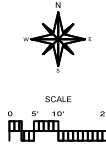

55 NEW CASTLE LN  
SEDONA, ARIZONA

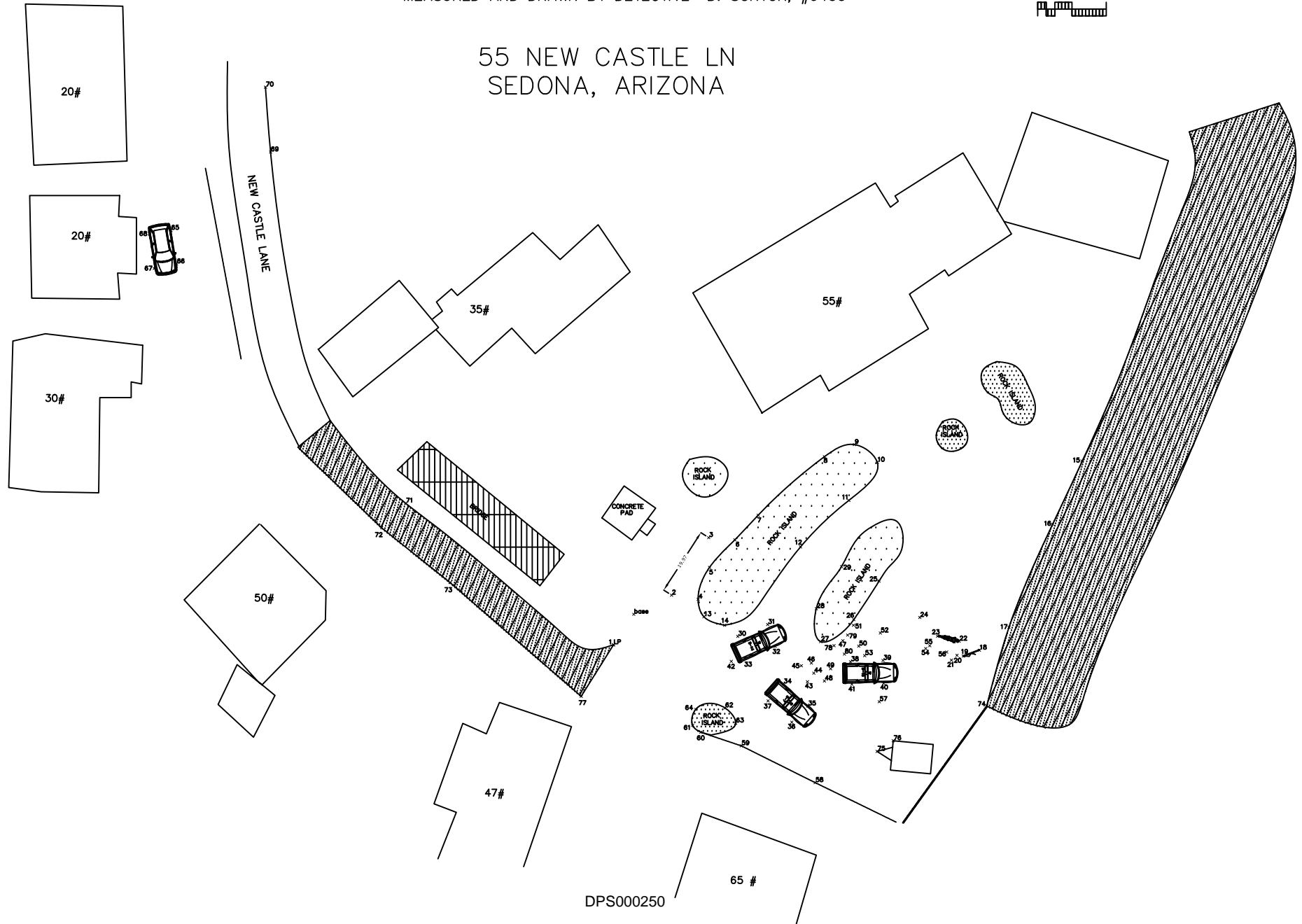

DPS000250

ARIZONA DEPARTMENT OF PUBLIC SAFETY  
VEHICULAR CRIMES UNIT

DATE	TIME	NCIC	OFFICER'S ID	REPORT NUMBER
2020/01/20	1332	0799	7325	I20003903

MEASURED AND DRAWN BY DETECTIVE D. SORTOR, #6400

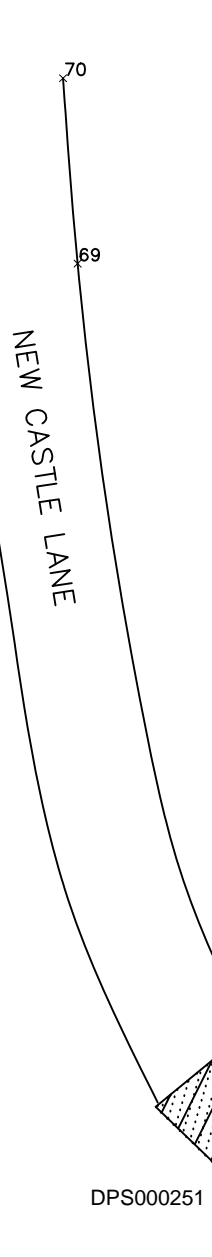
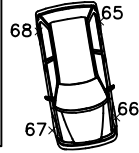
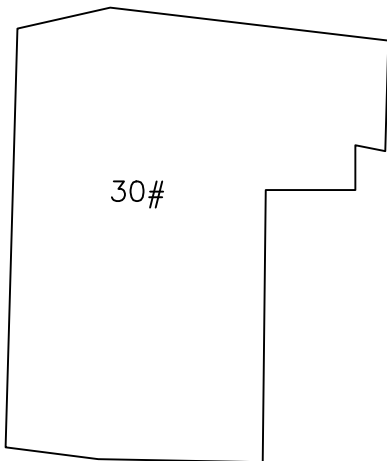
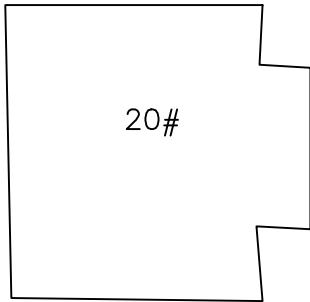
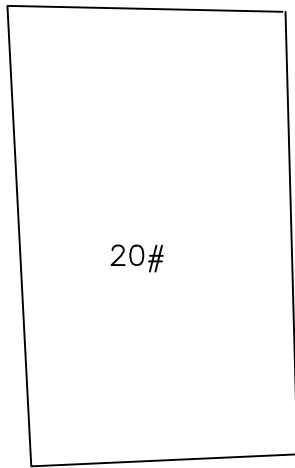
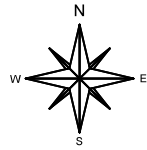

55 NEW CASTLE LN  
SEDONA, ARIZONA

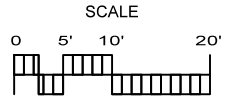
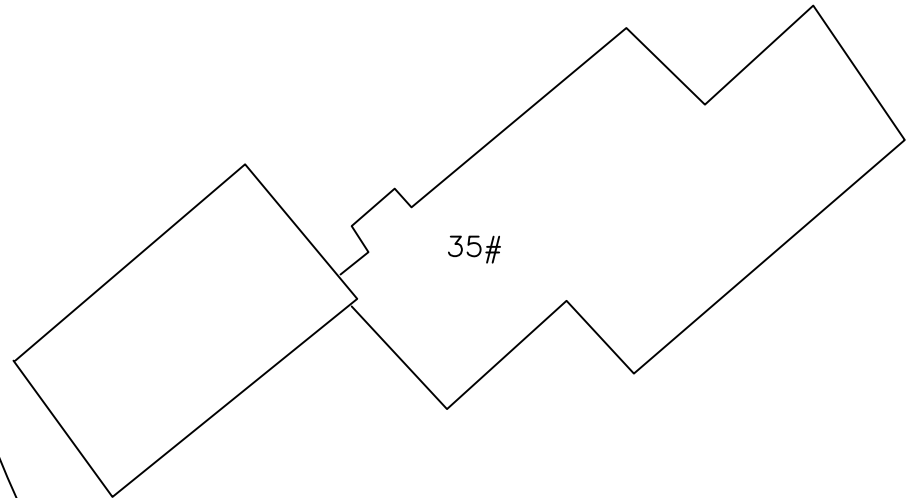

DPS000251

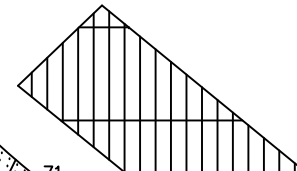

ARIZONA DEPARTMENT OF PUBLIC SAFETY  
VEHICULAR CRIMES UNIT

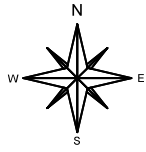

DATE	TIME	NCIC	OFFICER'S ID	REPORT NUMBER
2020/01/20	1332	0799	7325	I20003903

MEASURED AND DRAWN BY DETECTIVE D. SORTOR, #6400

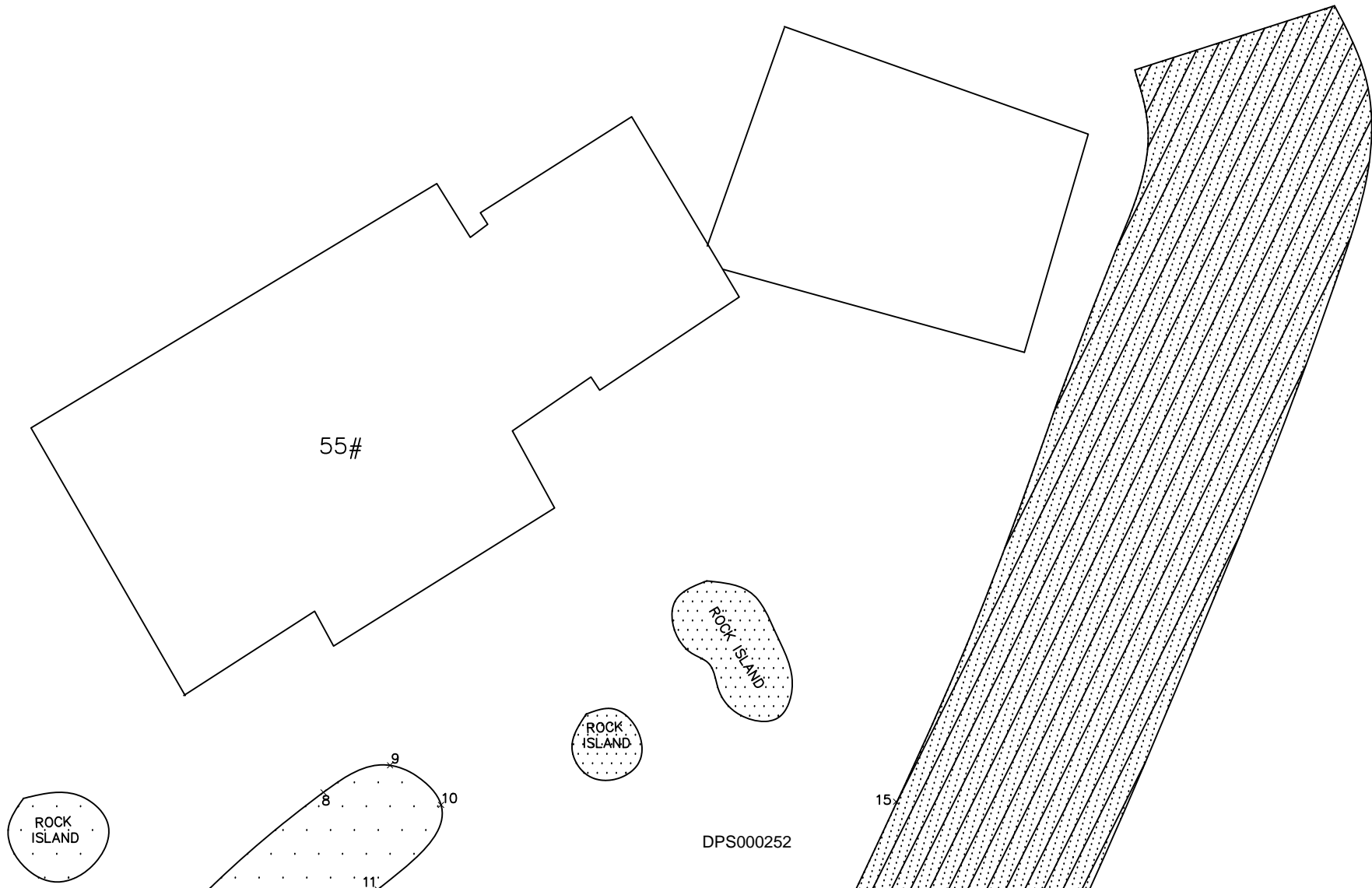

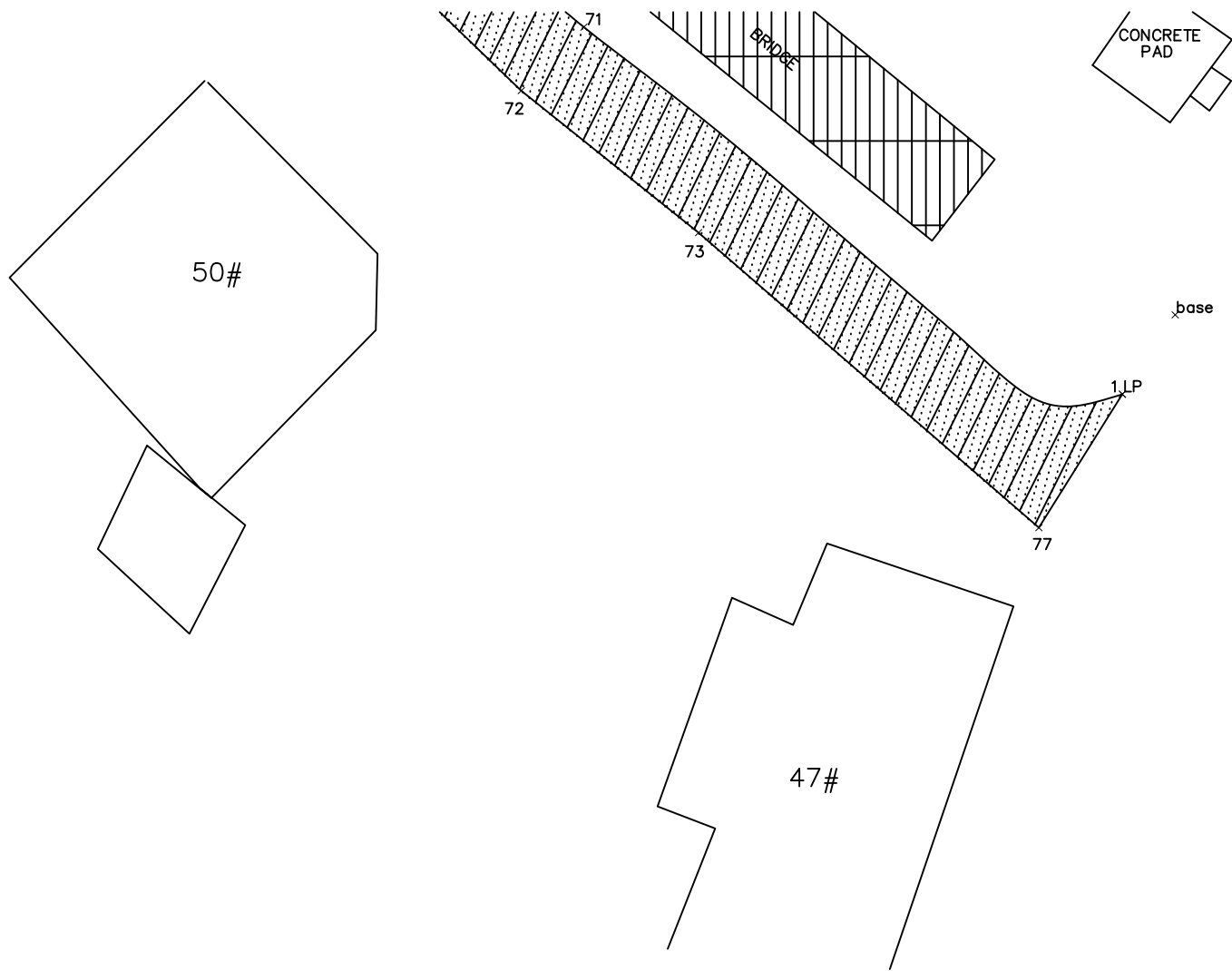

ARIZONA DEPARTMENT OF PUBLIC SAFETY  
VEHICULAR CRIMES UNIT

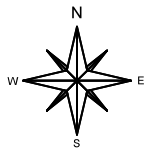

DATE	TIME	NCIC	OFFICER'S ID	REPORT NUMBER
2020/01/20	1332	0799	7325	120003903

MEASURED AND DRAWN BY DETECTIVE ~~DPS000253~~ D. SORTOR, #6400

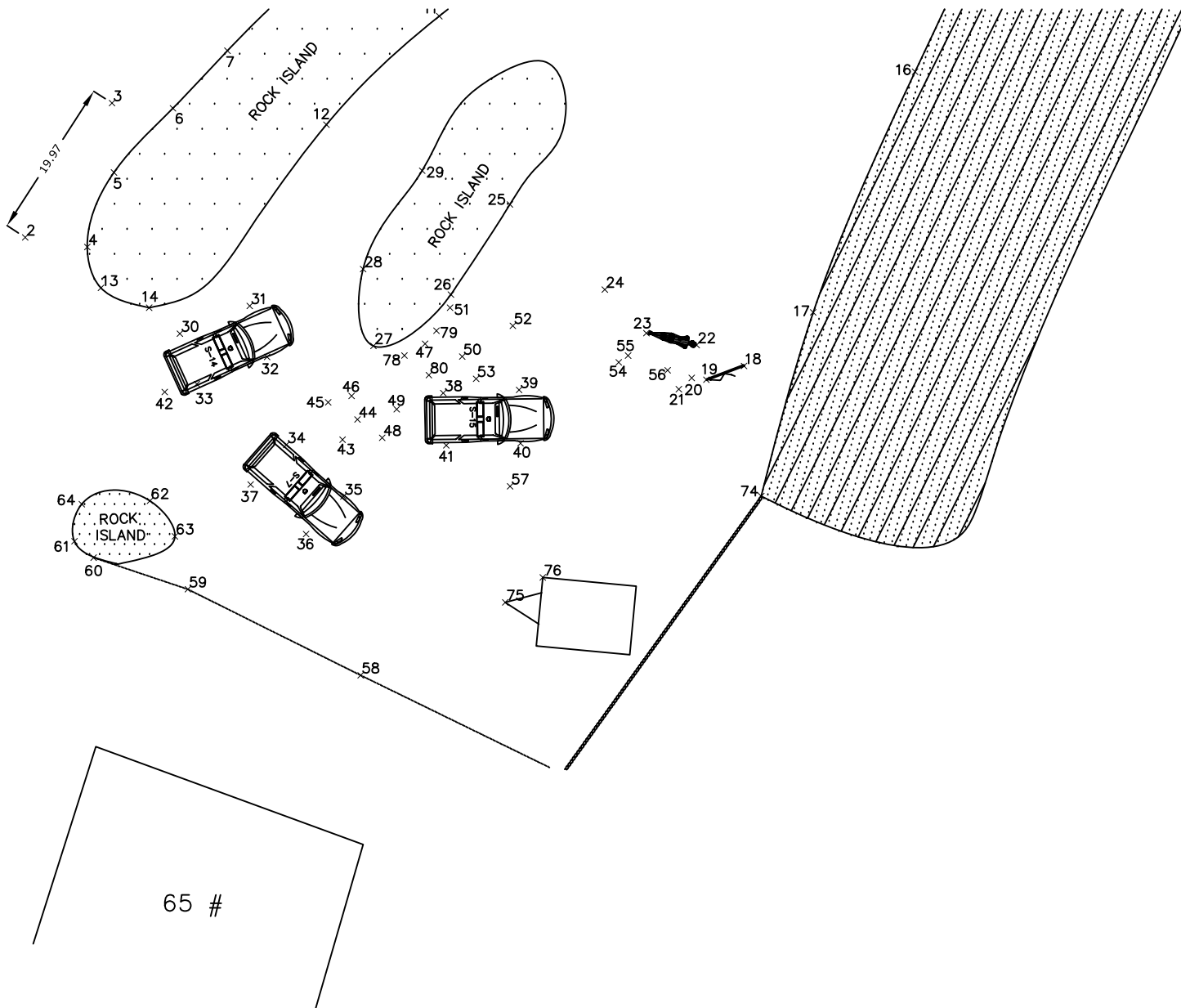

ARIZONA DEPARTMENT OF PUBLIC SAFETY  
VEHICULAR CRIMES UNIT

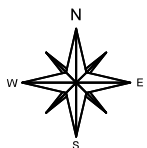

DATE	TIME	NCIC	OFFICER'S ID	REPORT NUMBER
2020/01/20	1332	0799	7325	120003903

MEASURED AND DRAWN BY DETECTIVE <sup>DPS000254</sup> D. SORTOR, #6400

ARIZONA DEPARTMENT OF PUBLIC SAFETY  
VEHICULAR CRIMES UNIT

DATE	TIME	NCIC	OFFICER'S ID	REPORT NUMBER
2020/01/20	1332	0799	7325	I20003903

MEASURED AND DRAWN BY DETECTIVE D. SORTOR, #6400

55 NEW CASTLE LN  
SEDONA, ARIZONA

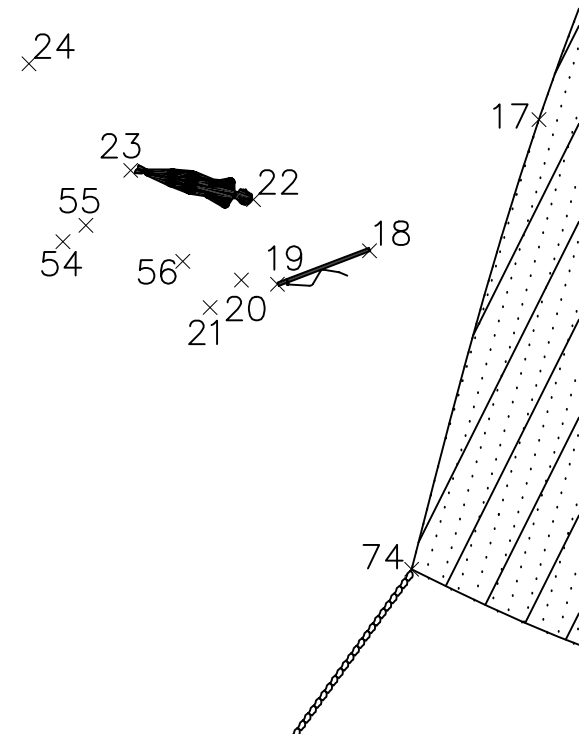
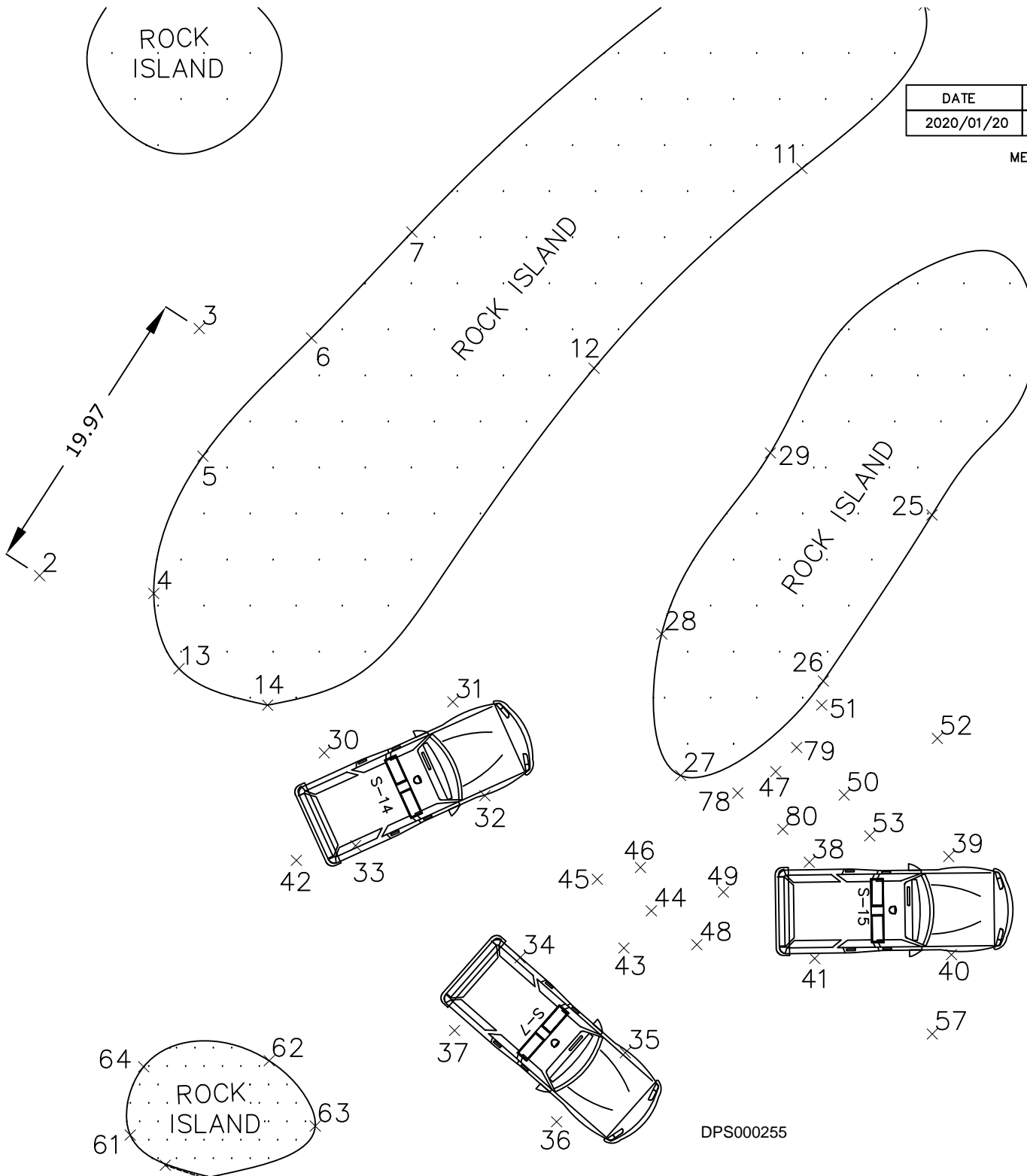
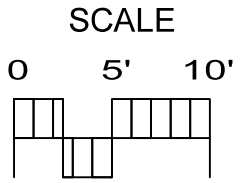
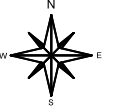

DPS000255

ARIZONA DEPARTMENT OF PUBLIC SAFETY  
VEHICULAR CRIMES UNIT

DATE	TIME	NCIC	OFFICER'S ID	REPORT NUMBER
2020/01/20	1332	0799	7325	I20003903

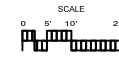

MEASURED AND DRAWN BY DETECTIVE D. SORTOR, #6400





ARIZONA DEPARTMENT OF PUBLIC SAFETY  
VEHICULAR CRIMES UNIT

DATE	TIME	NCIC	OFFICER'S ID	REPORT NUMBER
2020/01/20	1332	0799	7325	120003903

MEASURED AND DRAWN BY DETECTIVE D. SORTOR, #6400

55 NEW CASTLE LN  
SEDONA, ARIZONA

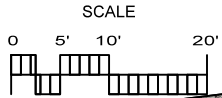

NEW CASTLE LANE

70  
69

35#

ARIZONA DEPARTMENT OF PUBLIC SAFETY  
VEHICULAR CRIMES UNIT



DATE	TIME	NCIC	OFFICER'S ID	REPORT NUMBER
2020/01/20	1332	0799	7325	I20003903

MEASURED AND DRAWN BY DETECTIVE D. SORTOR, #6400

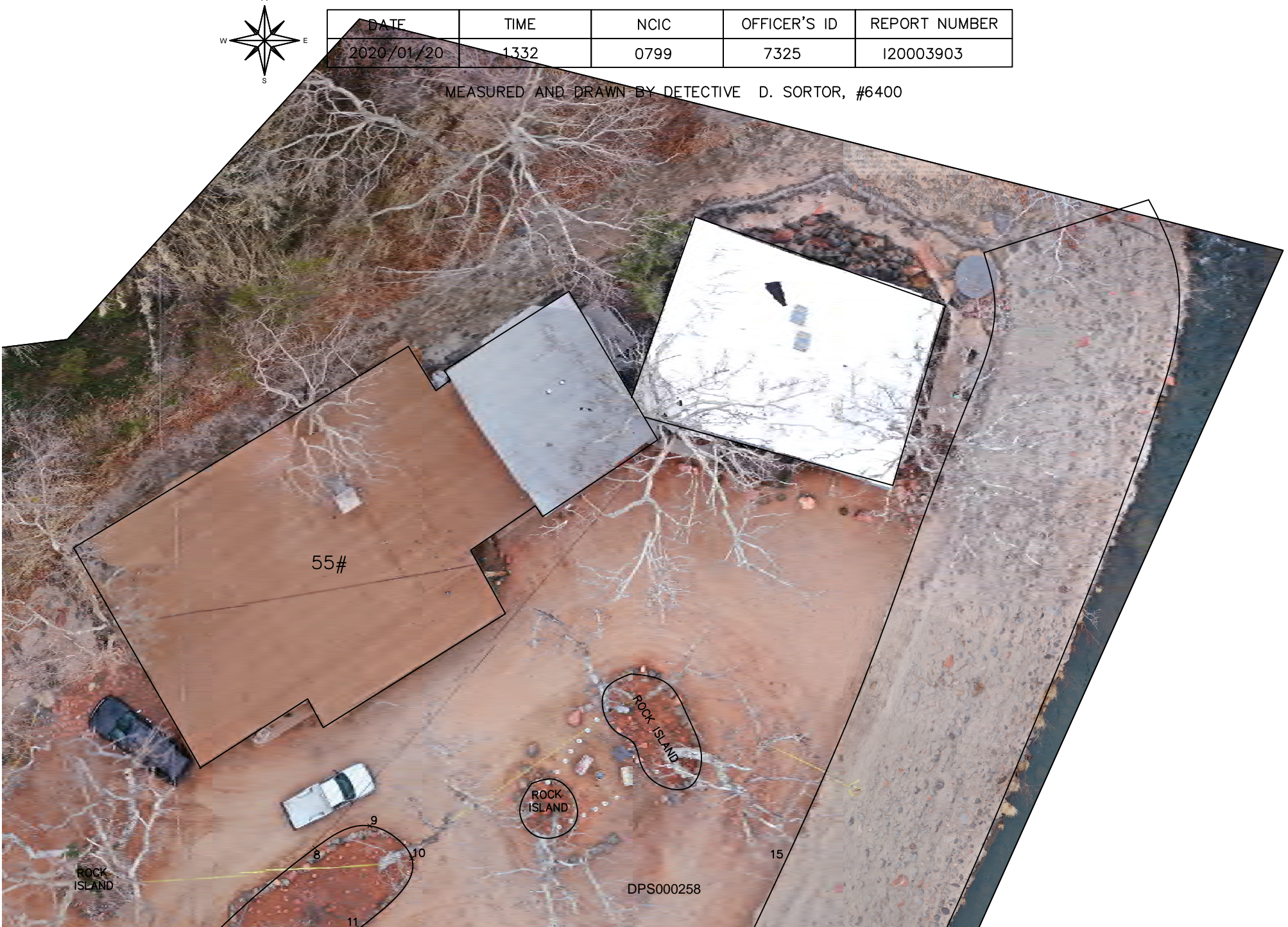



ARIZONA DEPARTMENT OF PUBLIC SAFETY  
VEHICULAR CRIMES UNIT

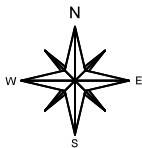

DATE	TIME	NCIC	OFFICER'S ID	REPORT NUMBER
2020/01/20	1332	0799	7325	I20003903

MEASURED AND DRAWN BY DETECTIVE ~~DPS000259~~ D. SORTOR, #6400



ARIZONA DEPARTMENT OF PUBLIC SAFETY  
VEHICULAR CRIMES UNIT

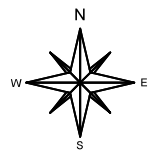

DATE	TIME	NCIC	OFFICER'S ID	REPORT NUMBER
2020/01/20	1332	0799	7325	120003903

MEASURED AND DRAWN BY DETECTIVE <sup>DPS000260</sup> D. SORTOR, #6400

ARIZONA DEPARTMENT OF PUBLIC SAFETY  
VEHICULAR CRIMES UNIT

DATE	TIME	NCIC	OFFICER'S ID	REPORT NUMBER
2020/01/20	1332	0799	7325	I20003903

MEASURED AND DRAWN BY DETECTIVE D. SORTOR, #6400

55 NEW CASTLE LN  
SEDONA, ARIZONA



SCALE

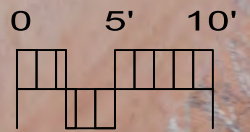

DPS000261

ARIZONA DEPARTMENT OF PUBLIC SAFETY  
VEHICULAR CRIMES UNIT

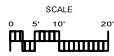

DATE	TIME	NCIC	OFFICER'S ID	REPORT NUMBER
2020/01/20	1332	0799	7325	120003903



MEASURED AND DRAWN BY DETECTIVE D. SORTOR, #6400

55 NEW CASTLE LN  
SEDONA, ARIZONA



DPS000262

ARIZONA DEPARTMENT OF PUBLIC SAFETY  
VEHICULAR CRIMES UNIT



DATE	TIME	NCIC	OFFICER'S ID	REPORT NUMBER
2020/01/20	1332	0799	7325	120003903

MEASURED AND DRAWN BY DETECTIVE D. SORTOR, #6400

55 NEW CASTLE LN  
SEDONA, ARIZONA

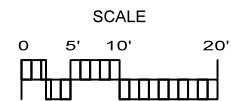

Castle Ln

ARIZONA DEPARTMENT OF PUBLIC SAFETY  
VEHICULAR CRIMES UNIT



DATE	TIME	NCIC	OFFICER'S ID	REPORT NUMBER
2020/01/20	1332	0799	7325	I20003903

MEASURED AND DRAWN BY DETECTIVE D. SORTOR, #6400

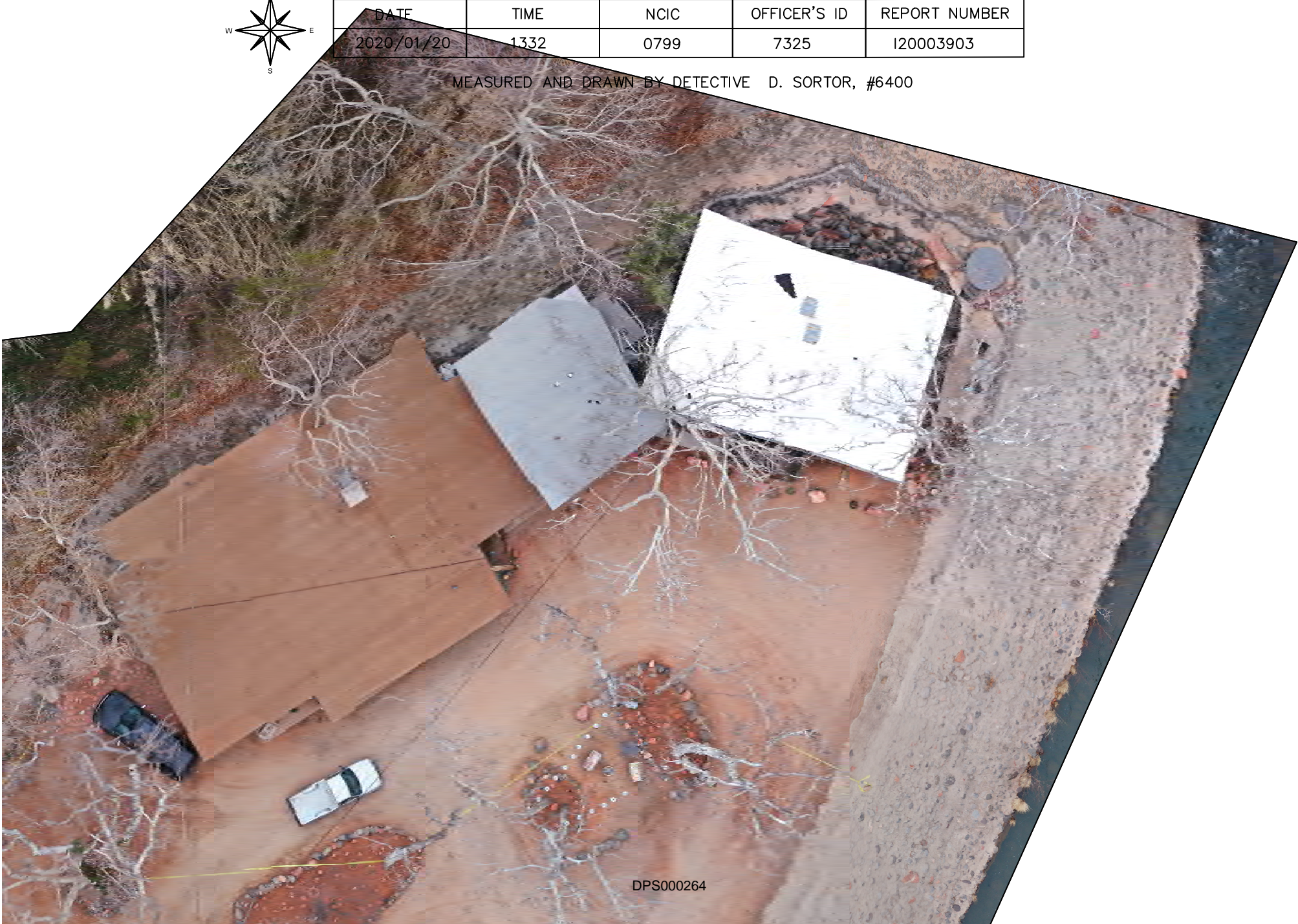

DPS000264





ARIZONA DEPARTMENT OF PUBLIC SAFETY  
VEHICULAR CRIMES UNIT

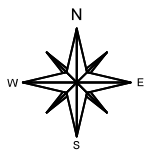

DATE	TIME	NCIC	OFFICER'S ID	REPORT NUMBER
2020/01/20	1332	0799	7325	I20003903

MEASURED AND DRAWN BY DETECTIVE D. SORTOR, #6400  
DPS000265



ARIZONA DEPARTMENT OF PUBLIC SAFETY  
VEHICULAR CRIMES UNIT

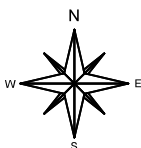

DATE	TIME	NCIC	OFFICER'S ID	REPORT NUMBER
2020/01/20	1332	0799	7325	I20003903

MEASURED AND DRAWN BY DETECTIVE D. SORTOR, #6400  
DPS000266

ARIZONA DEPARTMENT OF PUBLIC SAFETY  
VEHICULAR CRIMES UNIT

DATE	TIME	NCIC	OFFICER'S ID	REPORT NUMBER
2020/01/20	1332	0799	7325	120003903

MEASURED AND DRAWN BY DETECTIVE D. SORTOR, #6400

55 NEW CASTLE LN  
SEDONA, ARIZONA



SCALE

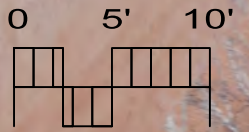

DPS000267

# ARIZONA DEPARTMENT OF PUBLIC SAFETY

## INCIDENT COMMAND SYSTEM LOG

SPD #: 200000881

DATE	1/20/20	TIME	1321	LOCATION	55 NEWCASTLE LN			DR#
<b>INCIDENT COMMANDER</b>	NAME		NAME		NAME			
	TIME		TIME		TIME			
TYPE OF INCIDENT				COMMAND POST LOCATION				
AGG. ASSAULT / THREATENING + INTIMIDATING / DISORDERLY CONDUCT / → OIC								
NAME	BADGE	CALL SIGN	ASSIGNMENT	AGENCY	TIME IN	TIME OUT		
DEP. E. CAHILL (YCSO)				YCSO		1445-1		
SGT. A. JARAMILLO (YCSO)				YCSO		1427		
SGT. G. MORAN (DPS)	5603	1240		DPS	1630 1400	1440		
LT. FOULI SPD	439			SPD	1412			
SGT. DORFMAN SPD	743			SPD	1417			
DLT. BERGSTAD SPD	850			SPD	1431	1538		
SGT. DOMINIQUEZ SPD	387			SPD	1444	2354		
CHIEF HUSTED SPD	987			SPD	1518	1522		
LT. WILCOXSON SPD	258			SPD	1505	2354		
Chief Husted SPD				SPD	1545	1550		
Det. Jared Gray D.P.S.				DPS	1555	1605		
P.S. McCARTY				DPS	1614	2324		
Michael Timink				CCAO	1616			
TECHNICAL ASSISTANCE	AGENCY	NAME	UNIT#	ADDITIONAL ASSISTANCE	AGENCY	NAME	UNIT#	
Fire								
Police								
Sheriff								
Ambulance								
Helicopter								
ADOT								
Tow Truck								
Haz Mat								

# ARIZONA DEPARTMENT OF PUBLIC SAFETY

## INCIDENT COMMAND SYSTEM LOG

TIME	MAJOR EVENT
	ON SCENE
	SGT. CASEY PELLETIER #624 VEHICLE 14
	OFC. BILL HUNT #461 VEHICLE 15
	OFC. KEVEN HUDSPETH #474 VEHICLE 7
	MEDICAL SEDONA FIRE DEPT
	MARC HOWARD #549
	JORDAN BAKER #304
	MILLAN ZORITA #412
	SEAN CUARTIER #214
	JAMEY KREUN #403
	JESSICA JOHNSTON (ACT) 7/31/78 (SFD) (206) 354-4604

1321

CHERYLE ~~958000~~ HARKELL DOF  
RESIDENT PH: [REDACTED]

# ARIZONA DEPARTMENT OF PUBLIC SAFETY

## INCIDENT COMMAND SYSTEM LOG

TIME	MAJOR EVENT	IN	OUT
DPS	Hemcock, Gunnar 6975	1621	
	McDonald, Jerome 6513	1621	
	Sgt Willis 6372	1621	2044
	Ryan, Leo 7618	1621	2044
	Gray, Sandro	1621	2044
DPS	Voss, Dan 6224	1633	2324
	LINARES, GILBERT 7587	1633	
	Ellis, Kenneth 6659	1633	2222
DPS	Philpot John 4808	1633	1750
SFD	Howard Marc 523	1645	1650 AM B 541
DPS	Vantassel Mity 7809	1645	
DPS	Kadelak Steve 6573	1645	
SFD	BIRUGLIO Phil 549	1645	1650 B/C 3
DPS	Sorter Daniel 6400	1645	2323
DPS	TOWN Dino 17893	1652	
DPS	Mowaco MAT 6645	1655	
DPS	REED Andy 7325	1705	
DPS	Fyfe Justin 7460	1705	
SPD	Charles Husted 987	1708	1750
DPS	O'BRYAN Sean 5501	1725	1746
DPS	Archambeau David 7280	1725	1808
DPS	Prounier Jason 6285	1725	1808
DPS	Ruble John 5627	1725	
DPS	Elliott Brad 5286	1725	1750
DPS	Bulger Jeremy 6754	1736	1808
CCAO	Kunk Michael	1801	7110
SPD	Bergstab Bradon 850		1803
SPD	Phil Wadsack 196		1832



# ARIZONA DEPARTMENT OF PUBLIC SAFETY

## INCIDENT COMMAND SYSTEM LOG

TIME	MAJOR EVENT	out
DPS	Seeley John 5208 1645	1826
1829	WIRKUS FRANCIS V38	2352
2016	PELLLETIER CASE 824	2026
2031	HUNT BILL 461	2037
2031	TOSTA HENRY	2037
2042	HUDSPETH KEVIN 474	7:20 2044 2100
	WILLIS WILL	2044
2020	BYRNE KATIE	2335
2020	ELTERS MAISIE	2335





04/01/20  
16:32

Sedona Police Department  
CALL DETAIL REPORT

Page: 305  
1

Call Number: C2001039

Nature: Weapon Offense  
Reported: 13:21:36 01/20/20  
Rcvd By: T Kendall How Rcvd: 9  
Occ Btwn: 13:21:36 01/20/20 and 13:31:49 01/20/20  
Type: 1  
Priority: 4

Address: 55 NEW CASTLE LN  
City: SEDONA

Alarm:

COMPLAINANT/CONTACT

Complainant: , Name#:   
Race: Sex: DOB: \*\*/\*\*/\*\*   
Address: ,   
Home Phone: Work Phone:

Contact: Cheryle Harrell  
Address:   
Phone:

RADIO LOG

Dispatcher	Time/Date	Unit	Code	Zone	Agnc	Description
A Leili	13:23:11 01/20/20	461	ENRT 3	SPD	incid#=200000881	Enroute to a Call call=171
A Leili	13:27:19 01/20/20	S1	ENRT 3	SPD	incid#=200000881	Enroute to a Call call=171
A Leili	13:27:31 01/20/20	474	ENRT 3	SPD	incid#=200000881	Enroute to a Call call=171
A Leili	13:29:19 01/20/20	461	ARRV 3	SPD	incid#=200000881	Arrived on Scene call=171
A Leili	13:29:20 01/20/20	474	ARRV 3	SPD	incid#=200000881	Arrived on Scene call=171
A Leili	13:29:20 01/20/20	S1	ARRV 3	SPD	incid#=200000881	Arrived on Scene call=171
A Leili	13:41:55 01/20/20	972	ARRV 3	SPD	incid#=200000881	Arrived on Scene call=171
T Kendall	13:45:25 01/20/20	972	CMPL 3	SPD	incid#=200000881	Completed Call clr:5 call=171
T Kendall	13:47:30 01/20/20	972	ARRV 3	SPD	incid#=200000881	c=171
T Kendall	13:47:40 01/20/20	972	ENRT 3	SPD	incid#=200000881	Enroute to a Call call=171
T Kendall	13:48:48 01/20/20	972	ARRV 3	SPD	incid#=200000881	Arrived on Scene call=171
T Kendall	13:50:42 01/20/20	972	CMPL 3	SPD	incid#=200000881	Completed Call call=171
A Leili	13:52:19 01/20/20	474	DLIN 3	SPD	last=messare first=jonathan mid=d* dob=	
A Leili	14:08:13 01/20/20	A2	ENRT 3	SPD	incid#=200000881	Enroute to a Call call=171

04/01/20  
16:32

Sedona Police Department  
CALL DETAIL REPORT

305  
Page: 2

A Leili	14:08:14	01/20/20	S3	ENRT	3	SPD	incid#=200000881	Enroute to a Call call=171
A Leili	14:12:44	01/20/20	A2	ARRV	3	SPD	incid#=200000881	Arrived on Scene call=171
A Leili	14:17:41	01/20/20	S3	ARRV	3	SPD	incid#=200000881	Arrived on Scene call=171
A Leili	14:38:04	01/20/20	S5	ENRT	3	SPD	incid#=200000881	Enroute to a Call call=171
T Kendall	14:42:55	01/20/20	D1	ARRV	3	SPD	incid#=200000881	c=171
T Kendall	14:43:01	01/20/20	D1	ARRV	3	SPD	Assigned as Responsible Unit for call C2001039	
T Kendall	14:43:09	01/20/20	D1	ENRT	3	SPD	incid#=200000881	Enroute to a Call call=171
T Kendall	14:44:36	01/20/20	D1	ARRV	3	SPD	incid#=200000881	Arrived on Scene call=171
T Kendall	14:44:50	01/20/20	S5	ARRV	3	SPD	incid#=200000881	Arrived on Scene call=171
T Kendall	14:45:05	01/20/20	A2	CMPL	3	SPD	incid#=200000881	Completed Call clr:5 call=171
A Leili	15:01:30	01/20/20	A3	ARRV	3	SPD	incid#=200000881	Arrived on Scene call=171
A Leili	15:30:17	01/20/20	S3	VHIN	3	SPD	pl=367bZR st=OR	
A Leili	15:49:56	01/20/20	D1	LOCT	3	SPD	Unit Location: PD	
N Dorfman	15:50:42	01/20/20	S3	NMIN		SPD	MDC: name=MESSARE, JONATHA*	
N Dorfman	15:50:43	01/20/20	S3	DLIN		SPD	MDC: name=MESSARE, JONATHA*	
N Dorfman	15:52:09	01/20/20	S3	VHIN		SPD	MDC: pl=387BZR st=OR	
N Dorfman	15:52:10	01/20/20	S3	VHRE		SPD	MDC: pl=387BZR st=OR	
T Kendall	16:22:13	01/20/20	461	LOCT	3	SPD	Unit Location: PD	
T Kendall	16:22:14	01/20/20	474	LOCT	3	SPD	Unit Location: PD	
T Kendall	16:22:14	01/20/20	S1	LOCT	3	SPD	Unit Location: PD	
T Kendall	16:34:30	01/20/20	S3	CMPL	3	SPD	incid#=200000881	Completed Call clr:5 call=171
T Kendall	16:37:26	01/20/20	S5	VHIN	3	SPD	pl=367bZR st=OR	
T Kendall	16:53:12	01/20/20	A3	VHIN	3	SPD	pl=cpc7651	
T Kendall	16:53:47	01/20/20	A3	DLIN	3	SPD	last=mcloughlin first=peter mid=a* dob=[REDACTED]	
S Wallace	17:41:40	01/20/20	D1	PD	3	SPD	call=171	
S Wallace	17:42:01	01/20/20	A3	ARRV	3	SPD	Assigned as Responsible Unit for call C2001039	
S Wallace	19:02:30	01/20/20	S3	DISP	3	SPD	incid#=200000881	Dispatched to Call call=171
S Wallace	19:02:43	01/20/20	S3	ENRT	3	SPD	call=171	
S Wallace	19:10:51	01/20/20	S3	ARRV	3	SPD	call=171	
S Wallace	19:51:26	01/20/20	A2	ARRV	3	SPD	incid#=200000881	c=171
S Wallace	19:52:09	01/20/20	578	ARRV	3	SPD	incid#=200000881	c=171
S Wallace	19:52:09	01/20/20	S1	ARRV	3	SPD	incid#=200000881	c=171
S Wallace	19:52:26	01/20/20	515	ARRV	3	SPD	incid#=200000881	c=171
S Wallace	19:52:27	01/20/20	461	ARRV	3	SPD	incid#=200000881	c=171
S Wallace	19:52:49	01/20/20	A2	ENRT	3	SPD	call=171	
S Wallace	19:52:53	01/20/20	578	ENRT	3	SPD	call=171	
S Wallace	19:52:55	01/20/20	461	ENRT	3	SPD	call=171	
S Wallace	19:52:56	01/20/20	515	ENRT	3	SPD	call=171	
S Wallace	19:53:19	01/20/20	461	ARRV	3	SPD	incid#=200000881	c=171
S Wallace	19:53:26	01/20/20	461	ENRT	3	SPD	call=171	
S Wallace	19:53:54	01/20/20	461	LOCT	3	SPD	Unit Location: 55 NEW CASTLE LN	
S Wallace	20:01:37	01/20/20	578	ARRV	3	SPD	call=171	

04/01/20  
16:32

Sedona Police Department  
CALL DETAIL REPORT

305  
Page: 3

S Wallace	20:01:37	01/20/20	A2	ARRV	3	SPD	call=171
T Tasa	20:04:06	01/20/20	515	ARRV	3	SPD	incid#=200000881 Arrived on Scene call=171
T Tasa	20:04:15	01/20/20	461	ARRV	3	SPD	incid#=200000881 Arrived on Scene call=171
N Dorfman	20:09:51	01/20/20	S3	NMIN		SPD	MDC: name=MESSARE
N Dorfman	20:09:52	01/20/20	S3	DLIN		SPD	MDC: name=MESSARE
N Dorfman	20:16:22	01/20/20	S3	CMPL	3	SPD	(MDC) Completed call incid#=200000881 call=171
S Wallace	20:50:42	01/20/20	578	CMPL	3	SPD	
S Wallace	20:50:43	01/20/20	S1	CMPL	3	SPD	
S Wallace	20:52:57	01/20/20	515	CMPL	3	SPD	incid#=200000881 Reassigned to call 311, completed call 171
S Wallace	21:02:00	01/20/20	461	OFF	3	SPD	
S Wallace	21:08:46	01/20/20	A2	CMPL	3	SPD	
S Wallace	21:08:57	01/20/20	461	CMPL	3	SPD	
S Wallace	22:12:33	01/20/20	474	CMPL	3	SPD	
S Wallace	23:32:07	01/20/20	436	DISP	3	SPD	incid#=200000881 Dispatched to Call call=171
S Wallace	23:32:07	01/20/20	515	DISP	3	SPD	incid#=200000881 Dispatched to Call call=171
S Wallace	23:32:07	01/20/20	521	DISP	3	SPD	incid#=200000881 Dispatched to Call call=171
S Wallace	23:32:07	01/20/20	S3	DISP	3	SPD	incid#=200000881 Dispatched to Call call=171
S Wallace	23:32:22	01/20/20	436	ENRT	3	SPD	call=171
S Wallace	23:32:22	01/20/20	515	ENRT	3	SPD	call=171
S Wallace	23:32:22	01/20/20	521	ENRT	3	SPD	call=171
S Wallace	23:32:22	01/20/20	S3	ENRT	3	SPD	call=171
S Wallace	23:38:38	01/20/20	436	ARRV	3	SPD	call=171
S Wallace	23:38:38	01/20/20	S3	ARRV	3	SPD	call=171
S Wallace	23:38:39	01/20/20	515	ARRV	3	SPD	call=171
S Wallace	23:38:39	01/20/20	521	ARRV	3	SPD	call=171
J Pott	23:58:23	01/20/20	436	CMPL	3	SPD	(MDC) Completed call incid#=200000881 call=171
S Wallace	23:58:27	01/20/20	515	CMPL	3	SPD	
S Wallace	23:58:40	01/20/20	S5	CMPL	3	SPD	
S Wallace	23:58:49	01/20/20	521	CMPL	3	SPD	
S Wallace	23:58:49	01/20/20	D1	CMPL	3	SPD	
S Wallace	23:58:49	01/20/20	S3	CMPL	3	SPD	
S Wallace	00:00:38	01/21/20	A3	CMPL	3	SPD	incid#=200000881 Completed Call disp:ACT clr:1 call=171
M Smith	07:36:16	01/21/20			3	SPD	Call type 1 reopened and assigned call number 2
M Smith	07:36:31	01/21/20	S2	DISP	3	SPD	incid#=200000881 Dispatched to Call call=21
M Smith	07:36:38	01/21/20	S2	ARRV	3	SPD	call=21
M Smith	07:36:46	01/21/20	S2	LOCT	3	SPD	Unit Location: PD - phone contact
M Smith	08:47:59	01/21/20	S2	CMPL	3	SPD	incid#=200000881 Completed Call call=21
M Smith	07:52:53	01/23/20			3	SPD	Call type 1 reopened and assigned call number 17
M Smith	07:53:14	01/23/20	D1	DISP	3	SPD	incid#=200000881 Dispatched to Call call=171
M Smith	07:53:22	01/23/20	D1	ENRT	3	SPD	call=171

04/01/20  
16:32

Sedona Police Department  
CALL DETAIL REPORT

305  
Page: 4

M Smith 07:53:35 01/23/20 D1 LOCT 3 SPD Unit Location: ME's office -  
Flagstaff  
M Smith 13:01:50 01/23/20 D1 ARRV 3 SPD call=171  
J Johnson 15:53:54 01/23/20 D1 CMPL 3 SPD incid#=200000881 Completed  
Call call=171

COMMENTS

-----

13:22:25 01/20/2020 - T Kendall  
RP reporting there is a man with a mowhawk on her property with a machete and a  
stick -  
13:22:56 01/20/2020 - T Kendall  
RP asked him to leave and he starting coming towards her and now he is outside  
yeklling  
13:23:18 01/20/2020 - A Leili  
Units code 3  
13:23:32 01/20/2020 - T Kendall  
male is white and is wearing camo style clothing  
13:24:09 01/20/2020 - T Kendall  
individual is stading on her retaining wall on oak creek and he has 2 dogs with  
him - one is a pitbull unknown what the other is  
13:24:27 01/20/2020 - T Kendall  
individual is not attempting to get into the property at thist ime  
13:24:38 01/20/2020 - T Kendall  
he is screaming about something  
13:24:55 01/20/2020 - T Kendall  
RP thinks that he is doing some sort of ritual...behavior is very off  
13:25:07 01/20/2020 - T Kendall  
individual is currently just sitting on the retaining wall  
13:25:37 01/20/2020 - T Kendall  
individual is wearing some sort of heavy vest with something underneath it  
13:25:57 01/20/2020 - T Kendall  
stick with feathers and stuff on it  
13:26:03 01/20/2020 - T Kendall  
possibly a walking stick  
13:26:20 01/20/2020 - T Kendall  
RP cannot understand what he is saying  
13:26:48 01/20/2020 - T Kendall  
\*EDITED\* FROM "RP reporting there is a man with a mowhawk on her property with a  
machete and a stick -" TO "RP reporting there is a man with a Mohawk on her  
property with a machete and a stick - "  
13:27:14 01/20/2020 - T Kendall  
Man is still sitting on the retaining wall  
13:27:23 01/20/2020 - T Kendall  
Cheryle Harrell property  
13:28:04 01/20/2020 - T Kendall  
RP is locked in her home  
13:28:23 01/20/2020 - T Kendall  
individual only has 1 dog - 2nd has left  
13:28:32 01/20/2020 - T Kendall  
dog seems docile  
13:29:23 01/20/2020 - T Kendall  
male is continuing to yell, sitting on the wall - he is chanting up to the sky,  
making movements like he is slicing himself  
13:29:45 01/20/2020 - T Kendall  
pitbull is in the rocks  
13:29:55 01/20/2020 - A Leili - From: B Hunt

04/01/20  
16:32

Sedona Police Department  
CALL DETAIL REPORT

305  
Page: 5

Got him sitting in front of me  
13:32:01 01/20/2020 - A Leili - From: B Hunt  
Shots Fired  
13:37:05 01/20/2020 - A Leili  
A3 notified  
13:37:29 01/20/2020 - T Kendall  
YCSO is enroute to assist with the scene and any traffic control that may be needed  
13:37:45 01/20/2020 - T Kendall  
6 deputys enroute  
13:40:19 01/20/2020 - A Leili - From: B Hunt  
Confirmed 901  
14:34:01 01/20/2020 - A Leili - From: S Foley  
Enroute to PD with 3 passengers  
14:38:21 01/20/2020 - A Leili - From: M Dominguez  
Enroute Code 3 down 89A past Midgley due to traffic  
14:59:10 01/20/2020 - A Leili - From: B Hunt  
\*EDITED\* FROM "Confirmed 901" TO "Confirmed 901 on subject. No officer injuries."  
Call type 1 reopened by M Smith at 07:36:17 01/21/20  
07:38:07 01/21/2020 - M Smith  
Kathleen Messare, wife of Jonathan Messare, calling for information - transferred to S2  
Call type 1 reopened by M Smith at 07:52:53 01/23/20

UNIT HISTORY

-----  
Unit Time/Date Code  
-----  
07:36:16 01/21/20  
07:52:53 01/23/20  
436 23:32:07 01/20/20 DISP  
436 23:32:22 01/20/20 ENRT  
436 23:38:38 01/20/20 ARRV  
436 23:58:23 01/20/20 CMPL  
461 13:23:11 01/20/20 ENRT  
461 13:29:19 01/20/20 ARRV  
461 16:22:13 01/20/20 LOCT  
461 19:52:27 01/20/20 ARRV  
461 19:52:55 01/20/20 ENRT  
461 19:53:19 01/20/20 ARRV  
461 19:53:26 01/20/20 ENRT  
461 19:53:54 01/20/20 LOCT  
461 20:04:15 01/20/20 ARRV  
461 21:02:00 01/20/20 OFF  
461 21:08:57 01/20/20 CMPL  
474 13:27:31 01/20/20 ENRT  
474 13:29:20 01/20/20 ARRV  
474 13:52:19 01/20/20 DLIN  
474 16:22:14 01/20/20 LOCT  
474 22:12:33 01/20/20 CMPL  
515 19:52:26 01/20/20 ARRV  
515 19:52:56 01/20/20 ENRT  
515 20:04:06 01/20/20 ARRV  
515 20:52:57 01/20/20 CMPL  
515 23:32:07 01/20/20 DISP

04/01/20  
16:32

Sedona Police Department  
CALL DETAIL REPORT

305  
Page: 6

515	23:32:22	01/20/20	ENRT
515	23:38:39	01/20/20	ARRV
515	23:58:27	01/20/20	CMPL
521	23:32:07	01/20/20	DISP
521	23:32:22	01/20/20	ENRT
521	23:38:39	01/20/20	ARRV
521	23:58:49	01/20/20	CMPL
578	19:52:09	01/20/20	ARRV
578	19:52:53	01/20/20	ENRT
578	20:01:37	01/20/20	ARRV
578	20:50:42	01/20/20	CMPL
972	13:41:55	01/20/20	ARRV
972	13:45:25	01/20/20	CMPL
972	13:47:30	01/20/20	ARRV
972	13:47:40	01/20/20	ENRT
972	13:48:48	01/20/20	ARRV
972	13:50:42	01/20/20	CMPL
A2	14:08:13	01/20/20	ENRT
A2	14:12:44	01/20/20	ARRV
A2	14:45:05	01/20/20	CMPL
A2	19:51:26	01/20/20	ARRV
A2	19:52:49	01/20/20	ENRT
A2	20:01:37	01/20/20	ARRV
A2	21:08:46	01/20/20	CMPL
A3	15:01:30	01/20/20	ARRV
A3	16:53:12	01/20/20	VHIN
A3	16:53:47	01/20/20	DLIN
A3	17:42:01	01/20/20	ARRV
A3	00:00:38	01/21/20	CMPL
D1	14:42:55	01/20/20	ARRV
D1	14:43:01	01/20/20	ARRV
D1	14:43:09	01/20/20	ENRT
D1	14:44:36	01/20/20	ARRV
D1	15:49:56	01/20/20	LOCT
D1	17:41:40	01/20/20	PD
D1	23:58:49	01/20/20	CMPL
D1	07:53:14	01/23/20	DISP
D1	07:53:22	01/23/20	ENRT
D1	07:53:35	01/23/20	LOCT
D1	13:01:50	01/23/20	ARRV
D1	15:53:54	01/23/20	CMPL
S1	13:27:19	01/20/20	ENRT
S1	13:29:20	01/20/20	ARRV
S1	16:22:14	01/20/20	LOCT
S1	19:52:09	01/20/20	ARRV
S1	20:50:43	01/20/20	CMPL
S2	07:36:31	01/21/20	DISP
S2	07:36:38	01/21/20	ARRV
S2	07:36:46	01/21/20	LOCT
S2	08:47:59	01/21/20	CMPL
S3	14:08:14	01/20/20	ENRT
S3	14:17:41	01/20/20	ARRV
S3	15:30:17	01/20/20	VHIN
S3	15:50:42	01/20/20	NMIN
S3	15:50:43	01/20/20	DLIN
S3	15:52:09	01/20/20	VHIN
S3	15:52:10	01/20/20	VHRE

04/01/20  
16:32

Sedona Police Department  
CALL DETAIL REPORT

Page: 305  
7

S3	16:34:30	01/20/20	CMPL
S3	19:02:30	01/20/20	DISP
S3	19:02:43	01/20/20	ENRT
S3	19:10:51	01/20/20	ARRV
S3	20:09:51	01/20/20	NMIN
S3	20:09:52	01/20/20	DLIN
S3	20:16:22	01/20/20	CMPL
S3	23:32:07	01/20/20	DISP
S3	23:32:22	01/20/20	ENRT
S3	23:38:38	01/20/20	ARRV
S3	23:58:49	01/20/20	CMPL
S5	14:38:04	01/20/20	ENRT
S5	14:44:50	01/20/20	ARRV
S5	16:37:26	01/20/20	VHIN
S5	23:58:40	01/20/20	CMPL

RESPONDING OFFICERS

Unit	Officer
436	J Pott
461	B Hunt
474	K Hudspeth
515	R Dominguez
521	M Lucas
578	T Langmack
972	C Beers
A2	S Foley
A3	L Wilcoxson
D1	B Bergstad
S1	C Pelletier
S2	L Leon
S3	N Dorfman
S5	M Dominguez

INVOLVEMENTS

Type	Record#	Date	Description	Relationship
LW	200000881	01/20/20	Weapon Offense 200000881 55	Initiating Call



Sedona Fire Department

Run #20-253

SFD - Phil Bruglio #549 – Pronounced subject deceased at the scene

SFD - Marc Howard #523 – Assisted Phil

Phil and Marc were the first SFD staff at the scene and rendered initial treatment.

PER MY DISCUSSION WITH PHIL & MARC

SGT. M. DOMINGUEZ 387

*M. Dominguez* 387

DET. BRANDON BERGSTAD  
#850

0857 - 1-23-20

Patient Information				Clinical Impression			
Last	MESSARE	Address	[REDACTED]	Primary Impression	Obvious Death		
First	JONATHAN	Address 2	[REDACTED]	Secondary Impression			
Middle		City	[REDACTED]	Protocol Used			
Gender	Male	State	[REDACTED]	Anatomic Position			
DOB		Zip	[REDACTED]	Chief Complaint	n/a		
Age	41 Years (estimated)	Country	[REDACTED]	Duration	10	Units	Minutes
Weight	200.0lbs - 90.7kg	Tel	[REDACTED]	Secondary Complaint			
Pedi Color		Physician		Duration		Units	
SSN	999999999	Ethnicity	Not Hispanic or Latino	Patient's Level of Distress			
Race	White			Signs & Symptoms	Obvious Death - Severe traumatic injuries		
Advance Directive	None			Injury	Firearms - Discharge of handgun (Undetermined Intent) - Home - 01/20/2020		
Resident Status	Sedona Resident			Medical/Trauma	Trauma		
				Barriers of Care	Unconscious		
				Alcohol/Drugs	None Reported		
				Pregnancy			
				Initial Patient Acuity			
				Final Patient Acuity			
				Patient Activity	Activity, Unspecified		

Medication/Allergies/History	
Medications	Other - unable to obtain
Allergies	Other drug allergy - unable to obtain
History	Other - unable to obtain

Vital Signs															
Time	AVPU	Side	POS	BP	Pulse	RR	SPO2	ETCO2	CO	BG	Temp	Pain	GCS(E+V+M)/Qualifier	RTS	PTS
13:39	Unresponsive		Lay	UTO	UTO	UTO	UTO	UTO	UTO	UTO	UTO	UTO			

ECG			
Time	Type	Rhythm	Notes
13:39	3-Lead	Asystole	

Flow Chart			
Time	Treatment	Description	Provider
13:39	3-Lead ECG	Comments pt deceased- asystole confirmed; Patient Response: Unchanged; Successful;	BRUGLIO, PHILLIP
13:50	Consult	Comments alyssa rn, ray md; Patient Response: Unchanged;	BRUGLIO, PHILLIP

Initial Assessment			
Category	Comments	Abnormalities	
Mental Status	pt deceased	Mental Status	+ Unresponsive
Skin	pt had visible wound on his rt bicep	Skin	+ Other
HEENT		Head/Face	Not Assessed
		Eyes	Not Assessed
		Neck/Airway	Not Assessed
Chest	pt had blood spots from wounds on his torso	Chest	Not Assessed
		Heart Sounds	Not Assessed
		Lung Sounds	Not Assessed
Abdomen		General	Not Assessed
		Left Upper	Not Assessed
		Right Upper	Not Assessed
		Left Lower	Not Assessed
		Right Lower	Not Assessed
Back		Cervical	Not Assessed
		Thoracic	Not Assessed
		Lumbar/Sacral	Not Assessed
Pelvis/GU/GI		Pelvis/GU/GI	Not Assessed

Initial Assessment			
Category	Comments	Abnormalities	
Extremities		Left Arm	Not Assessed
		Right Arm	Not Assessed
		Left Leg	Not Assessed
		Right Leg	Not Assessed
		Pulse	Not Assessed
		Capillary Refill	Not Assessed
Neurological		Neurological	Not Assessed

Assessment Time: 01/20/2020 13:37:00

**Narrative**  
E541 and A541 dispatched for a gun shot wound per Sedona PD. Upon arrival crew found a 41 y/o male pt laying supine on the ground, in hand cuffs with two SPD members searching him for weapons. As A541 crew approached the pt was rolled over on to his left side by SPD. The pt had what appeared to be gunshot wounds to his rt arm and chest and appeared deceased. The monitor was attached to confirm pt death. Monitor showed asystole. Pt death was pronounced at 1340hrs and A541 crew removed the monitor and remained on scene until released by SPD.

Incident Details		Destination Details		Incident Times	
Location Type	Home/Residence	Disposition	Patient Dead on Scene - No Resuscitation Attempted (Without Transport)	PSAP Call	13:31:27
Location	[REDACTED]	Transport Due To		Dispatch Notified	
Address		Transported To		Call Received	13:31:27
Address 2		Requested By	Law Enforcement	Dispatched	13:32:28
Mile Marker		Destination		En Route	13:33:23
City		Department		Resp on Scene	
County		Address		On Scene	13:36:01
State		Address 2		At Patient	13:37:00
Zip		City		Care Transferred	
Medic Unit	A541	County		Depart Scene	14:56:33
Medic Vehicle	A541	State		At Destination	
Run Type	911 Response	Zip		Pt. Transferred	14:56:33
Priority Scene	Emergent	Zone		Call Closed	14:56:33
Shift	C Shift	Condition at Destination		In District	
Zone	405	Destination Record #		At Landing Area	
Level of Service	Advanced Life Support	Trauma Registry ID			
EMD Complaint	Stab/Gunshot Wound/Penetrating Trauma	STEMI Registry ID			
EMD Card Number		Stroke Registry ID			

Crew Members		
Personnel	Role	Certification Level
BRUGLIO, PHILLIP	Lead	EMT-Paramedic (Arizona) - P00082740
HOWARD, MARC	Driver	
ZORITA, MILLAN	Other	EMT-Paramedic (Arizona) - P00062341
CHARTIER, SEAN	Other	EMT-Basic (Arizona) - E00058358
KREUN, JAMEY	Other	EMT-Paramedic (Arizona) - P00059820

Mileage		Delays		Additional Agencies	
Scene	Mileage	Category	Delays		
Destination	0.0	Dispatch Delays	None/No Delay		
Loaded Miles	0.1	Response Delays	None/No Delay		
Start		Scene Delays	Other (Not Listed)		
End		Transport Delays	None/No Delay		
Total Miles		Turn Around Delays	None/No Delay		



**Billing Authorization**

Authorization

**Section I - Patient / Parent of Minor Authorization Signature**

Signature

Signed On

Notice of Privacy Practices Provided

Printed Parent Name

Billing Authorization

HIPAA Acknowledgement

**Section II - Authorized Representative Signature**

Complete this section only if the patient is physically or mentally unable to sign.  
Authorized representatives include only the following:(Check one)

- Patient's Legal Guardian
- Patient's Medical Power of Attorney
- Relative or other person who receives benefits on behalf of the patient
- Relative or other person who arranges treatment or handles the patient's affairs
- Representative of an agency or institution that provided care, services or assistance to patient

I am signing on behalf of the patient to authorize the submission of a claim for payment to Medicare, Medicaid, or any other payer for any services provided to the patient by the transporting ambulance service now or in the past or in the future. By signing below, I acknowledge that I am one of the authorized signers listed below. **My signature is not an acceptance of financial responsibility for the services rendered.**

Signature

Signed On

Notice of Privacy Practices Provided

Printed Name

Reason unable to sign

**Section III - EMS Personnel and Facility Signatures**

Complete this section if the patient was mentally or physically incapable of signing, and no Authorized Representative (section II) was available or willing to sign on behalf of the patient at the time of service.

**EMS Personnel Signature**

My signature below indicates that, at the time of service, the patient was physically or mentally incapable of signing, and that none of the authorized representatives listed in Section II of this form were available or willing to sign on the patient's behalf. **My signature is not an acceptance of financial responsibility for the services rendered.**

--	--

<b>Signed On</b>	
<b>Printed Name</b>	
<b>Reason unable to sign</b>	

**Facility Representative Signature**

The patient named on this form was received by this facility on the date and at the time indicated and this facility furnished care, services or assistance to the patient. **My signature is not an acceptance of financial responsibility for the services rendered..**

--	--

<b>Signed On</b>	
<b>Notice of Privacy Practices Provided</b>	
<b>Printed Name</b>	
<b>Title of Representative</b>	

**Facility Signatures**

--	--

<b>Signed On</b>	
<b>Receiving</b>	

--	--

<b>Signed On</b>	
<b>Paperwork Received</b>	

--	--

<b>Signed On</b>	
<b>Airway Confirmation</b>	



Provider Signatures



<b>Lead Provider</b>	BRUGLIO, PHILLIP	<b>Certification Level</b>	EMT-Paramedic (Arizona) - P00082740
----------------------	------------------	----------------------------	-------------------------------------

<b>Provider</b>		<b>Certification Level</b>	
-----------------	--	----------------------------	--

<b>Provider</b>		<b>Certification Level</b>	
-----------------	--	----------------------------	--

<b>Provider</b>		<b>Certification Level</b>	
-----------------	--	----------------------------	--

<b>Provider</b>		<b>Certification Level</b>	
-----------------	--	----------------------------	--

<b>Provider</b>		<b>Certification Level</b>	
-----------------	--	----------------------------	--

<b>Provider</b>		<b>Certification Level</b>	
-----------------	--	----------------------------	--

**A** FDID  \* State  \* Incident Date    \* Station  Incident Number  \* Exposure  \*  Delete  Change  No Activity NFIRS -1 Basic

**B Location\***  Check this box to indicate that the address for this incident is provided on the Wildland Fire Census Tract  -  Module in Section B "Alternative Location Specification". Use only for Wildland fires.

Street address       
 Number/Milepost Prefix Street or Highway Street Type Suffix

Intersection  In front of  Rear of  Adjacent to  Directions   
   -    
 Apt./Suite/Room City State Zip Code

Cross street or directions, as applicable

**C Incident Type \***     
 Incident Type

**E1 Date & Times** Midnight is 0000   
 Check boxes if dates are the same as Alarm Date. ALARM always required   
 Alarm \*       
 Month Day Year Hr Min Sec

**E2 Shift & Alarms** Local Option   
    
 Shift or Alarms District   
 Platoon

**D Aid Given or Received\***   
 1  Mutual aid received     
 2  Automatic aid recv. Their FDID Their State   
 3  Mutual aid given     
 4  Automatic aid given Their Incident Number   
 5  Other aid given   
 N  None

**E3 Special Studies** Local Option   
    
 Special Study ID# Special Study Value

**E1 Date & Times** (continued)   
 ARRIVAL required, unless canceled or did not arrive   
 Arrival \*       
 CONTROLLED Optional, Except for wildland fires   
 Controlled   
 LAST UNIT CLEARED, required except for wildland fires   
 Last Unit Cleared

**F Actions Taken \***   
    
 Primary Action Taken (1)   
    
 Additional Action Taken (2)   
    
 Additional Action Taken (3)

**G1 Resources \***   
 Check this box and skip this section if an Apparatus or Personnel form is used.   
 Apparatus Personnel   
 Suppression     
 EMS     
 Other     
 Check box if resource counts include aid received resources.

**G2 Estimated Dollar Losses & Values**   
 LOSSES: Required for all fires if known. Optional for non fires. None   
 Property \$  ,  ,     
 Contents \$  ,  ,     
 PRE-INCIDENT VALUE: Optional   
 Property \$  ,  ,     
 Contents \$  ,  ,

**Completed Modules**   
 Fire-2  Structure-3  Civil Fire Cas.-4  Fire Serv. Cas.-5  EMS-6  HazMat-7  Wildland Fire-8  Apparatus-9  Personnel-10  Arson-11

**H1\* Casualties**  None   
 Deaths Injuries   
 Fire Service     
 Civilian     
**H2 Detector** Required for Confined Fires.   
 1  Detector alerted occupants   
 2  Detector did not alert them   
 U  Unknown

**H3 Hazardous Materials Release**   
 N  None   
 1  Natural Gas: slow leak, no evacuation or HazMat actions   
 2  Propane gas: <21 lb. tank (as in home BBQ grill)   
 3  Gasoline: vehicle fuel tank or portable container   
 4  Kerosene: fuel burning equipment or portable storage   
 5  Diesel fuel/fuel oil: vehicle fuel tank or portable   
 6  Household solvents: home/office spill, cleanup only   
 7  Motor oil: from engine or portable container   
 8  Paint: from paint cans totaling < 55 gallons   
 0  Other: Special HazMat actions required or spill > 55gal., Please complete the HazMat form

**I Mixed Use Property**   
 NN  Not Mixed   
 10  Assembly use   
 20  Education use   
 33  Medical use   
 40  Residential use   
 51  Row of stores   
 53  Enclosed mall   
 58  Bus. & Residential   
 59  Office use   
 60  Industrial use   
 63  Military use   
 65  Farm use   
 00  Other mixed use

**J Property Use\*** Structures   
 131  Church, place of worship   
 161  Restaurant or cafeteria   
 162  Bar/Tavern or nightclub   
 213  Elementary school or kindergarten   
 215  High school or junior high   
 241  College, adult education   
 311  Care facility for the aged   
 331  Hospital

341  Clinic, clinic type infirmary   
 342  Doctor/dentist office   
 361  Prison or jail, not juvenile   
 419  1-or 2-family dwelling   
 429  Multi-family dwelling   
 439  Rooming/boarding house   
 449  Commercial hotel or motel   
 459  Residential, board and care   
 464  Dormitory/barracks   
 519  Food and beverage sales

539  Household goods, sales, repairs   
 579  Motor vehicle/boat sales/repair   
 571  Gas or service station   
 599  Business office   
 615  Electric generating plant   
 629  Laboratory/science lab   
 700  Manufacturing plant   
 819  Livestock/poultry storage (barn)   
 882  Non-residential parking garage   
 891  Warehouse

Outside   
 124  Playground or park   
 655  Crops or orchard   
 669  Forest (timberland)   
 807  Outdoor storage area   
 919  Dump or sanitary landfill   
 931  Open land or field

936  Vacant lot   
 938  Graded/care for plot of land   
 946  Lake, river, stream   
 951  Railroad right of way   
 960  Other street   
 961  Highway/divided highway   
 962  Residential street/driveway

981  Construction site   
 984  Industrial plant yard

Lookup and enter a Property Use code only if you have NOT checked a Property Use box:   
 Property Use

**K1 Person/Entity Involved**

Local Option

Business name (if applicable)

Area Code

Phone Number

 Check This Box if same address as incident location. Then skip the three duplicate address lines.

Mr., Ms., Mrs.	First Name	MI	Last Name	Suffix
Number	Prefix	Street or Highway	Street Type	Suffix
Post Office Box	Apt./Suite/Room	City		
State	Zip Code			

 More people involved? Check this box and attach Supplemental Forms (NFIRS-1S) as necessary
**K2 Owner**

Local Option

 Same as person involved? Then check this box and skip the rest of this section.

Business name (if Applicable)

Area Code

Phone Number

 Check this box if same address as incident location. Then skip the three duplicate address lines.

Mr., Ms., Mrs.	First Name	MI	Last Name	Suffix
Number	Prefix	Street or Highway	Street Type	Suffix
Post Office Box	Apt./Suite/Room	City		
State	Zip Code			

**L Remarks**

Local Option

Responded to "MALE SUBJ W/ GSW/ PD ON SCENE REQ C3". On arrival found male subject on the ground pulseless and apneic in the custody of SPD. 4-lead ECG was acquired with confirmation of Asystole. Patch was made by charge medic Bruglio to pronounce death. ACT was called for assistance with witness. E541, A541 and B53 were released from incident but were required to leave A541 and B53 vehicles in place by law enforcement.

MALE SUBJ W/ GSW/PD ON  
 SCENE/REQ C3  
 13:32:08 01/20/2020 - JACOBS, B (ProQA Medical)  
 ProQA Case Cancelled: 10.  
 Call from Public Safety Agency  
 13:35:15 01/20/2020 - NOSS, J M  
 PER E541, STAGE AT SEC,  
 LAUNCH HELO PER BC, LZ IS SEC  
 13:35:48 01/20/2020 - JACOBS, B  
 GUARDIAN ENRT TO SEC  
 W/ 18 MIN ETA  
 13:36:34 01/20/2020 - JACOBS, B  
 SEC HAS BEEN ADVISED AND HELIO IS IN BOUND  
  
 13:38:56 01/20/2020 - NOSS, J M

**L Authorization**

403	Kreun, Jamey M	ENG		01	20	2020
Officer in charge ID	Signature	Position or rank	Assignment	Month	Day	Year

Check Box if same as Officer in charge.	<input checked="" type="checkbox"/>	403	Kreun, Jamey M	ENG		01	20	2020
Member making report ID		Signature	Position or rank	Assignment	Month	Day	Year	



**Narrative:**

Responded to "MALE SUBJ W/ GSW/ PD ON SCENE REQ C3". On arrival found male subject on the ground pulseless and apneic in the custody of SPD. 4-lead ECG was acquired with confirmation of Asystole. Patch was made by charge medic Bruglio to pronounce death. ACT was called for assistance with witness. E541, A541 and B53 were released from incident but were required to leave A541 and B53 vehicles in place by law enforcement.

MALE SUBJ W/ GSW/PD ON SCENE/REQ C3

13:32:08 01/20/2020 - JACOBS, B (ProQA Medical)  
 ProQA Case Cancelled: 10. Call from Public Safety Agency  
 13:35:15 01/20/2020 - NOSS, J M  
 PER E541, STAGE AT SEC, LAUNCH HELO PER BC, LZ IS SEC  
 13:35:48 01/20/2020 - JACOBS, B  
 GUARDIAN ENRT TO SEC W/ 18 MIN ETA  
 13:36:34 01/20/2020 - JACOBS, B  
 SEC HAS BEEN ADVISED AND HELIO IS IN BOUND  
 13:38:56 01/20/2020 - NOSS, J M  
 CXL HELO, DISPATCH ACT  
 13:40:58 01/20/2020 - NOSS, J M  
 PER SPD RADIO, PT IS 901  
 13:41:51 01/20/2020 - JACOBS, B  
 ACT HAS BEEN ADVISED ON THE SITUATION WILL CALL BACK W/ AN ETA  
 13:45:25 01/20/2020 - NOSS, J M  
 BC53 EST NEW CASTLE CMND  
 13:48:36 01/20/2020 - JACOBS, B  
 ACT ENRT W/ 30 MIN ETA OR LESS  
 13:49:24 01/20/2020 - NOSS, J M  
 SDC REQ RESPONSE TO STA54 AT THIS TIME, WILL ADV IF THEY NEED TO CHANGE  
 LOCATION  
 13:51:33 01/20/2020 - JACOBS, B  
 ACT PAGE SENT OUT FOR NEW LOCATION TO 45  
 14:13:49 01/20/2020 - JACOBS, B  
 SEDONA FIRE REQ ACT SEND ANOTHER VOLUNTEER AND 45 AT 55 NEW CASTLE LN AT E541  
 14:15:51 01/20/2020 - JACOBS, B  
 ACT HAS BEEN ADVISED TO SEND ANOTHER VOLUNTEER AND MEET AT ENGINE ON NEW  
 CASTLE/ACT WILL ATTEMPT TO SEND ANOTHER VOLUNTEER  
 14:32:11 01/20/2020 - JACOBS, B  
 ACT IS SENDING ANOTHER VOLUNTEER W/ AN ETA OF 30 MIN  
 14:35:51 01/20/2020 - NOSS, J M  
 PER SDC, CXL 2ND ACT VOLUNTEER  
 14:37:04 01/20/2020 - NOSS, J M  
 2ND ACT VOLUNTEER CXL

01/21/20  
17:33

COTTONWOOD POLICE DEPARTMENT  
CALL DETAIL REPORT

Page: 508  
1

Call Number: 785766

Nature: EMS ASSIGNMENT  
Reported: 13:31:27 01/20/20  
Rcvd By: JACOBS, B How Rcvd: T  
Occ Btwn: 13:31:20 01/20/20 and 13:31:20 01/20/20  
Type: f  
Priority: 1

Address: 55 NEW CASTLE LN; AREA 5405;STN 4  
City: SEDONA

Alarm:

COMPLAINANT/CONTACT

Complainant: , Name#:   
Race: Sex: DOB: \*\*/\*\*/\*\*   
Address: ,   
Home Phone: Work Phone:

Contact: SEDONA PD  
Address:  
Phone: ( ) -

RADIO LOG

Dispatcher	Time/Date	Unit	Code	Zone	Agnc	Description
NOSS, J M	13:32:28 01/20/20	A541	ASSGN	5401	SFD	incid#=S20000253 ASSIGNED TO A CALL call=78f
NOSS, J M	13:32:28 01/20/20	E541	ASSGN	5401	SFD	incid#=S20000253 ASSIGNED TO A CALL call=78f
NOSS, J M	13:32:28 01/20/20	STA54	ASSGN	5401	SFD	incid#=S20000253 ASSIGNED TO A CALL call=78f
NOSS, J M	13:33:10 01/20/20	STA54	CMPLT	5401	SFD	incid#=S20000253 COMPLETED CALL call=78f
NOSS, J M	13:33:22 01/20/20	E541	ENRT	5401	SFD	incid#=S20000253 ENROUTE TO A CALL call=78f
NOSS, J M	13:33:23 01/20/20	A541	ENRT	5401	SFD	incid#=S20000253 ENROUTE TO A CALL call=78f
NOSS, J M	13:33:29 01/20/20	SDC	ENRT	5401	SFD	incid#=S20000253 ENROUTE TO A CALL call=78f
NOSS, J M	13:36:01 01/20/20	A541	ARRVD	5401	SFD	incid#=S20000253 ARRIVED ON SCENE call=78f
NOSS, J M	13:36:01 01/20/20	E541	ARRVD	5401	SFD	incid#=S20000253 ARRIVED ON SCENE call=78f
NOSS, J M	13:36:07 01/20/20	SDC	ARRVD	5401	SFD	incid#=S20000253 ARRIVED ON SCENE call=78f
NOSS, J M	13:39:05 01/20/20	ACT	ASSGN	5401	ACT	incid#=3200 ASSIGNED TO A CALL call=78f
NOSS, J M	14:27:51 01/20/20	ACT	ARRVD	5401	ACT	incid#=3200 ONSCENE call=78f
NOSS, J M	14:56:33 01/20/20	A541	CMPLT	5401	SFD	incid#=S20000253 COMPLETED CALL call=78f
NOSS, J M	14:56:33 01/20/20	E541	CMPLT	5401	SFD	incid#=S20000253 COMPLETED CALL call=78f

01/21/20  
17:33

COTTONWOOD POLICE DEPARTMENT  
CALL DETAIL REPORT

Page: 508  
2

NOSS, J M 15:53:21 01/20/20 A541 ARRVD 5401 SFD incid#=S20000253 ARRIVED ON SCENE call=78f  
NOSS, J M 15:53:40 01/20/20 A541 ARRVD 5401 SFD incid#=S20000253 ONSCENE UFN PER MARC call=78f  
CORSETTE, 16:36:31 01/20/20 SDC CMPLT 5401 SFD incid#=S20000253 Reassigned to call 96f, completed call 78f  
NOSS, J M 17:12:24 01/20/20 A541 CMPLT 5401 SFD incid#=S20000253 COMPLETED CALL call=78f  
MALDONADO, 17:42:25 01/20/20 ACT CMPLT 5401 ACT incid#=3200 COMPLETED CALL call=78f

COMMENTS

-----  
MALE SUBJ W/ GSW/PD ON SCENE/REQ C3  
13:32:08 01/20/2020 - JACOBS, B (ProQA Medical)  
ProQA Case Cancelled: 10. Call from Public Safety Agency  
13:35:15 01/20/2020 - NOSS, J M  
PER E541, STAGE AT SEC, LAUNCH HELO PER BC, LZ IS SEC  
13:35:48 01/20/2020 - JACOBS, B  
GUARDIAN ENRT TO SEC W/ 18 MIN ETA  
13:36:34 01/20/2020 - JACOBS, B  
SEC HAS BEEN ADVISED AND HELIO IS IN BOUND  
13:38:56 01/20/2020 - NOSS, J M  
CXL HELO, DISPATCH ACT  
13:40:58 01/20/2020 - NOSS, J M  
PER SPD RADIO, PT IS 901  
13:41:51 01/20/2020 - JACOBS, B  
ACT HAS BEEN ADVISED ON THE SITUATION WILL CALL BACK W/ AN ETA  
13:45:25 01/20/2020 - NOSS, J M  
BC53 EST NEW CASTLE CMND  
13:48:36 01/20/2020 - JACOBS, B  
ACT ENRT W/ 30 MIN ETA OR LESS  
13:49:24 01/20/2020 - NOSS, J M  
SDC REQ RESPONSE TO STA54 AT THIS TIME, WILL ADV IF THEY NEED TO CHANGE LOCATION  
13:51:33 01/20/2020 - JACOBS, B  
ACT PAGE SENT OUT FOR NEW LOCATION TO 45  
14:13:49 01/20/2020 - JACOBS, B  
SEDONA FIRE REQ ACT SEND ANOTHER VOLUNTEER AND 45 AT 55 NEW CASTLE LN AT E541  
14:15:51 01/20/2020 - JACOBS, B  
ACT HAS BEEN ADVISED TO SEND ANOTHER VOLUNTEER AND MEET AT ENGINE ON NEW CASTLE/ACT WILL ATTEMPT TO SEND ANOTHER VOLUNTEER  
14:32:11 01/20/2020 - JACOBS, B  
ACT IS SENDING ANOTHER VOLUNTEER W/ AN ETA OF 30 MIN  
14:35:51 01/20/2020 - NOSS, J M  
PER SDC, CXL 2ND ACT VOLUNTEER  
14:37:04 01/20/2020 - NOSS, J M  
2ND ACT VOLUNTEER CXL

UNIT HISTORY

-----  
Unit Time/Date Code  
-----  
A541 13:32:28 01/20/20 ASSGN  
A541 13:33:23 01/20/20 ENRT

01/21/20  
17:33

COTTONWOOD POLICE DEPARTMENT  
CALL DETAIL REPORT

Page: 508  
3

A541	13:36:01	01/20/20	ARRVD
A541	14:56:33	01/20/20	CMPLT
A541	15:53:21	01/20/20	ARRVD
A541	15:53:40	01/20/20	ARRVD
A541	17:12:24	01/20/20	CMPLT
ACT	13:39:05	01/20/20	ASSGN
ACT	14:27:51	01/20/20	ARRVD
ACT	17:42:25	01/20/20	CMPLT
E541	13:32:28	01/20/20	ASSGN
E541	13:33:22	01/20/20	ENRT
E541	13:36:01	01/20/20	ARRVD
E541	14:56:33	01/20/20	CMPLT
SDC	13:33:29	01/20/20	ENRT
SDC	13:36:07	01/20/20	ARRVD
SDC	16:36:31	01/20/20	CMPLT
STA54	13:32:28	01/20/20	ASSGN
STA54	13:33:10	01/20/20	CMPLT

RESPONDING OFFICERS

Unit	Officer
A541	A541
ACT	ACT
E541	E541
SDC	BAKER, J
SDC	CHIEF, SFD BATT
SDC	COCHRANE, D
SDC	COIL, J
SDC	LECHOWSKI, E
SDC	MEZULIS, E
SDC	OFFICER, DUTY
STA54	SEDONA FD

INVOLVEMENTS

Type	Record#	Date	Description	Relationship
FR	3200	01/20/20	EMS ASSIGNMENT 3200	Initiating Call
FR	S20000253	01/20/20	EMS ASSIGNMENT S20000253	Initiating Call

ARIZONA DEPARTMENT OF PUBLIC SAFETY  
SEARCH WARRANT  
IN THE SUPERIOR COURT  
COUNTY OF COCONINO, STATE OF ARIZONA

Warrant Number: 2020-000788

AZDPS Incident Number: I20003903

STATE OF ARIZONA

VS

Jonathan David Messare

Date of Birth: [REDACTED]  
Height: 5'11"  
Weight: 180 lbs.  
Eye Color: Blue  
Hair Color: Brown  
Social Security Number: [REDACTED]  
State Identification/Driver License Number: [REDACTED]  
Address: [REDACTED]

To any peace officer in the County of Coconino, State of Arizona. Proof by affidavit having been made this day before me by Arizona Department of Public Safety Detective Gilbert Linares, #7577, that there is probable cause to believe that:

- On the premises or building known as:

-Dirt lot/parking area in front of 55 and 65 New Castle Lane, Sedona, Arizona

-71B New Castle Lane, Sedona, Arizona which is a single level pink stucco with white trim single family home, the front door faces East and is white in color with a gold doorknob. The numbers "71B" are on the northeast corner of the residence in black numbers/letters and face east.

- In the vehicle describe herein:

Honda, Ridgeline, Pick-Up Truck  
Color: Maroon  
Oregon Registration: 367BZR  
Vehicle Identification Number: 2HJYK16516H501520  
Registered Owner: Hugh Edward Boyanton

There is per A.R.S. 13-3912

There is now being possessed or concealed certain property, things, or a person which:

- Was used as means of committing a public offense.
- Constitutes an item or evidence which tends to show that, the above listed person, has committed the public offense of ARS 13-1204A1 Aggravated Assault, and ARS 13-1204A8A Aggravated Assault on a Peace Officer.

You are therefore commanded;

- In the daytime (6:30 a.m. until 10:00 p.m.)

To make a search of the above described;

- Premises or Buildings
- Vehicle(s)

for the following property, person(s) or thing(s) and if you find such, or any parts thereof, to retain such in your custody subject to A.R.S. 13-3920:

1. Any and all firearms, expended cartridge casings, expended pieces of projectiles and or fragments, bullet strikes and impacts.
2. Any and all other firearms, cartridges, cartridge casings, identifiable bullet holes, bullet fragments, expended pieces of lead and or bullet material which may link a person(s) to the scene, person(s) position, and or position of a person(s) firing a firearm into or out of a structure, vehicle or other object.
3. Any knife, machete, bladed weapon, stick or any object which could have been perceived as a weapon in the possession of Messare.
4. Any or all other evidence which would tend to show the crimes of ARS 13-1204A1 Aggravated Assault, and ARS 13-1204A8A Aggravated Assault on a Peace Officer.
5. Any clothing worn by any individual involved in the investigation which may contain evidence of the crime.
6. Any traces of blood, deoxyribonucleic acid (DNA), hair, skin or other biological material, latent fingerprints to include, but not limited to, palm prints or other contact marks which may be used for identification of person(s).
7. Any material fibers found in the area of the above described property which may be needed to include or exclude materials found on and/or with a suspect(s) and/or victim(s).
8. Any cellular telephone, which may contain data of commonly called numbers. A subsequent search warrant shall be obtained prior to retrieving information from the seized cellular telephone.

- 9. Any personal effects, to include, but not limited to, insurance, driver's license, bank cards, receipts, identifiable personal property, other identifiable personal paperwork or any other documentation which will serve in identifying the suspect in this case.
- 10. Any and all other material evidence of violations of: ARS 13-1204A1 Aggravated Assault, and ARS 13-1204A8A Aggravated Assault on a Peace Officer.
- 11. Any indicia of occupancy or residency to include mail, bills, handwritten notes, photographs, or any item which would prove residency for the above listed suspect.

Given under my hand or direction this 20th day of January, 2020.

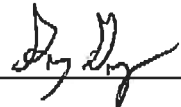
X  \_\_\_\_\_  
 Judge or Magistrate of the Superior Court

HONORABLE GREGORY J. GNEPPER  
MARICOPA COUNTY SUPERIOR COURT



# ARIZONA DEPARTMENT OF PUBLIC SAFETY RETURN OF SEARCH WARRANT

Detective G. Linares #7577, a peace officer in the State of Arizona, being duly sworn upon oath, deposes and says:

That on the 20th day of January, 2020, Detective G. Linares #7577, executed this search warrant, number SW2020-000788, and the following described property or things examined or seized:

- See Attached Search Warrant Receipts.

Detective Linares further certifies that the foregoing inventory is true and detailed account of all the property taken by him pursuant to A.R.S. 13-3921.

  
 Affiant, Detective G. Linares #7577  
 Arizona Department of Public Safety

SUBSCRIBED AND SWORN TO before me this 22 day of January, 2020

  
 Judge  
 of the Maricopa County Superior Court

HONORABLE GREGORY J. GNEPPER  
MARICOPA COUNTY SUPERIOR COURT





ARIZONA DEPARTMENT OF PUBLIC SAFETY

SEARCH WARRANT RECEIPT / EVIDENCE LIST

DR NUMBER	120003903
ENTRY TIME	9:56PM
EXIT TIME	12:02AM

TODAY'S DATE:		RECORDER BADGE NO.	AFFIANT / OFFICER	SEARCH WARRANT ADDRESS	
01/20/2020		J. Ruble, #5627	G. Linares, #7577	55 Newcastle Lane Sedona Arizona	
ITEM NO.	TIME FOUND	ITEM FOUND BY:	BADGE NO.	DESCRIPTION	LOCATION
MV1	2157	Van Tassel	07809	1 pair Black Nitrile Gloves	Behind Vehicle #14
MV2	2158	Van Tassel	07809	Shell Casing, FC 9MM Lugar	North of Vehicle #15
MV3	2159	Van Tassel	07809	Shell Casing, FC 9MM Lugar	North of Vehicle #15
MV4	2200	Van Tassel	07809	Shell Casing, FC 9MM Lugar	North of Vehicle #15
MV5	2201	Van Tassel	07809	Shell Casing, FC 9MM Lugar	North of Vehicle #15
MV6	2202	Van Tassel	07809	Shell Casing, FC 9MM Lugar	North of Vehicle #15
MV7	2203	Van Tassel	07809	Shell Casing, FC 9MM Lugar	North of Vehicle #15
MV8	2204	Van Tassel	07809	4 Loose gloves next to box	Northeast of Vehicle #15
MV9	2207	Van Tassel	07809	ECCG Electro Bag	South of Vehicle #12
MV10	2208	Van Tassel	07809	Sun Glasses (Kaanon)	Southeast of Vehicle #12
MV11	2209	Van Tassel	07809	Walking Stick w/ Pouch & 2 green balls	East of deceased subject
MV12	2312	Van Tassel	07809	Deceased Male	On ground of inner perimeter
MVA.1	2229	Van Tassel	07809	L3 Disc	From Vehicle #15
MVB.1	2239	Van Tassel	07809	PNY 32gb SD Card	From Vehicle #7
MVB.2	2249	Van Tassel	07809	Oregon DL A874956	On top of Hood of Vehicle #7
MVB.3	2259	Van Tassel	07809	1 pair Black Nitrile Gloves	Behind Vehicle #7 on the ground
MVB.4	2300	Van Tassel	07809	Red Buck Knife w/ Wood Handle	Rear Cargo area of Vehicle #7
MVB.5	2302	Van Tassel	07809	Hatchet w/ case	Rear Cargo area of Vehicle #7
MVB.6	2304	Van Tassel	07809	Sword	Rear Cargo area of Vehicle #7

CASE AGENT NAME	BADGE NO.	RETAINER NAME:	BADGE NO.
A. Reed	07325	Van Tassel	07809

**DISTRIBUTION:** COPY 1 - COURT COPY 2 - OFFICER COPY 3 - RECEIPT



ARIZONA DEPARTMENT OF PUBLIC SAFETY

SEARCH WARRANT RECEIPT / EVIDENCE LIST

DR NUMBER	120003903
ENTRY TIME	9:56PM
EXIT TIME	12:02AM

ITEM NO.	TIME FOUND	ITEM FOUND BY:	BADGE NO.	DESCRIPTION	LOCATION
TODAY'S DATE: 01/20/2020					
RECORDER BADGE NO. J. Ruble, #5627			AFFIANT / OFFICER G. Linares, #7577		
MVB.7	2306	Van Tassel	07809	White Sheet that contained MVB.4 - 7	Rear Cargo area of Vehicle #7
MVA.2	2322	Van Tassel	07809	EKG Printout	Front Seat of Vehicle #15
MVC.1	2326	Van Tassel	07809	SN #CF0231739	From Vehicle #14
MV12.1	2357	Van Tassel	07809	White Blanket	Covering Deceased

CASE AGENT NAME	BADGE NO.	RETAINER NAME:	BADGE NO.
A. Reed	07325	Van Tassel	07809
<b>DISTRIBUTION:</b>			
COPY 1 - COURT	COPY 2 - OFFICER	COPY 3 - RECEIPT	



**SEARCH WARRANT RECEIPT / EVIDENCE LIST**

DR NUMBER I20003903	
ENTRY TIME 9:56PM	EXIT TIME 12:02AM

TODAY'S DATE: 01/20/2020		RECORDER BADGE NO. J. Ruble, #5627	AFFIANT / OFFICER G. Linares, #7577	SEARCH WARRANT ADDRESS 55 Newcastle Lane Sedona Arizona	
ITEM NO.	TIME FOUND	ITEM FOUND BY:	BADGE NO.	DESCRIPTION	LOCATION
MV1	2157	Van Tassel	07809	1 pair Black Nitrile Gloves	Behind Vehicle #14
MV2	2158	Van Tassel	07809	Shell Casing, FC 9MM Lugar	North of Vehicle #15
MV3	2159	Van Tassel	07809	Shell Casing, FC 9MM Lugar	North of Vehicle #15
MV4	2200	Van Tassel	07809	Shell Casing, FC 9MM Lugar	North of Vehicle #15
MV5	2201	Van Tassel	07809	Shell Casing, FC 9MM Lugar	North of Vehicle #15
MV6	2202	Van Tassel	07809	Shell Casing, FC 9MM Lugar	North of Vehicle #15
MV7	2203	Van Tassel	07809	Shell Casing, FC 9MM Lugar	North of Vehicle #15
MV8	2204	Van Tassel	07809	4 Loose gloves next to box	Northeast of Vehicle #15
MV9	2207	Van Tassel	07809	ECG Electro Bag	South of Vehicle #12
MV10	2208	Van Tassel	07809	Sun Glasses (Kaenon)	Southeast of Vehicle #12
MV11	2209	Van Tassel	07809	Walking Stick w/ Pouch & 2 green balls	East of deceased subject
MV12	2312	Van Tassel	07809	Deceased Male	On ground of inner perimeter
MVA.1	2229	Van Tassel	07809	L3 Disc	From Vehicle #15
MVB.1	2239	Van Tassel	07809	PNY 32gb SD Card	From Vehicle #7
MVB.2	2249	Van Tassel	07809	Oregon DL A874956	On top of Hood of Vehicle #7
MVB.3	2259	Van Tassel	07809	1 pair Black Nitrile Gloves	Behind Vehicle #7 on the ground
MVB.4	2300	Van Tassel	07809	Red Buck Knife w/ Wood Handle	Rear Cargo area of Vehicle #7
MVB.5	2302	Van Tassel	07809	Hatchet w/ case	Rear Cargo area of Vehicle #7
MVB.6	2304	Van Tassel	07809	Sword	Rear Cargo area of Vehicle #7

CASE AGENT NAME A. Reed	BADGE NO. 07325	RETAINER NAME: Van Tassel	BADGE NO. 07809
----------------------------	--------------------	------------------------------	--------------------

**DISTRIBUTION:** COPY 1 - COURT COPY 2 - OFFICER COPY 3 - RECEIPT



# SEARCH WARRANT RECEIPT / EVIDENCE LIST

DR NUMBER I20003903	
ENTRY TIME 9:56PM	EXIT TIME 12:02AM

TODAY'S DATE: 01/20/2020		RECORDER BADGE NO. J. Ruble, #5627	AFFIANT / OFFICER G. Linares, #7577		SEARCH WARRANT ADDRESS 55 Newcastle Lane, Sedona Arizona
ITEM NO.	TIME FOUND	ITEM FOUND BY:	BADGE NO.	DESCRIPTION	LOCATION
MVB.7	2306	Van Tassel	07809	White Sheet that contained MVB.4 - 7	Rear Cargo area of Vehicle #7
MVA.2	2322	Van Tassel	07809	EKG Printout	Front Seat of Vehicle #15
MVC.1	2326	Van Tassel	07809	SN #CF0231739	From Vehicle #14
MV12.1	2357	Van Tassel	07809	White Blanket	Covering Deceased

CASE AGENT NAME A. Reed	BADGE NO. 07325	RETAINER NAME: Van Tassel	BADGE NO. 07809
----------------------------	--------------------	------------------------------	--------------------

**DISTRIBUTION:** COPY 1 - COURT COPY 2 - OFFICER COPY 3 - RECEIPT





ARIZONA DEPARTMENT OF PUBLIC SAFETY

SEARCH WARRANT

STATE OF ARIZONA, COUNTY OF MARICOPA

State of Arizona  
Plaintiff

No. 2020-000834  
AZDPS Incident Number: I20003903

Vs.

Defendant

*Jonathan David Messare*

Date of Birth: [REDACTED]  
Height: 5'11"  
Weight: 180 lbs.  
Eye Color: Blue  
Hair Color: Brown  
Social Security Number: [REDACTED]  
State Identification/Driver License Number: [REDACTED]  
Address: [REDACTED]

TO ANY PEACE OFFICER IN MARICOPA COUNTY, STATE OF ARIZONA,  
Proof of affidavit having been made this day before me by Detective G. Linares #7577, I  
am satisfied that there is probable cause to believe that;

On the premises known as the Arizona Department of Public Safety, 2102 W Encanto  
Boulevard, Phoenix, Arizona there is:

- A black CAT Cellular Phone with no visible identifying numbers belonging to  
Jonathan David Messare.

Which contains evidence of, **ARS § 13-1204A.1 Aggravated Assault, and ARS § 13-1204A.8.A Aggravated Assault on a Peace Officer.**

1. All electronic communications, including those previously received or transmitted, and those in transmission, or held in temporary, intermediate storage incident to transmission: The terms "records, documents and materials, including those used to facilitate communications" as used above shall include any and all communications, previously received, transmitted, or stored or prepared in contemplation of transmission, or any communications in the process of being received or transmitted, including electronic mail or data associated with

electronic bulletin board systems, whether stored on any of the electronic media named above or held in temporary, intermediate storage incident to transmission to the individuals or premises within the scope of this application. Also to include: Any and all electronic media stored in a removable or fixed memory system on said electronic device, to include all photographs, videos, text messages, emails, and other data and documentation of said files and phone to include date and time of photographs or other data files taken and any other included information indicating ownership or possession of said phone, electronic device or data files, to include addresses and/or telephone books and papers reflecting names, addresses, and/or telephone numbers of any persons identified as victims or co-conspirators. All the records above, whether stored on magnetic media such as tape, cassette, disk, diskette or on memory storage devices such as optical disks, programmable instruments such as, "electronic address books," calculators or any other storage media, together with indicia of use, ownership, possession or control of such records.

- 2. Saved locations, routes of travel, destinations, previous locations traveled, or any other information to identify who may be co-conspirators, or persons involved in: **ARS § 13-1204A.1 Aggravated Assault, and ARS § 13-1204A.8.A Aggravated Assault on a Peace Officer.**
- 3. Any applications, utility programs, compilers, interpreters and other software used to facilitate direct or indirect communication with the computer hardware, storage devices or data to be searched.

Material evidence of violations of: **ARS § 13-1204A.1 Aggravated Assault, and ARS § 13-1204A.8.A Aggravated Assault on a Peace Officer.**

Which person, property or things:

- was used as a means for committing a public offense
- was possessed with the intent to use it as a means of committing a public offense
- are in the possession of The Arizona Department of Public Safety
- consists of any items or constitutes any evidence which tends to show that the herein described public offense has been committed, or tends to show that a particular person(s) has committed said offense.

Such being more fully described in the affidavit, to wit: **ARS § 13-1204A.1 Aggravated Assault, and ARS § 13-1204A.8.A Aggravated Assault on a Peace Officer.**



Which offense occurred on or about the 20th day of January, 2020, in the County of Coconino, State of Arizona.

**YOU ARE THEREFORE COMMANDED**

- In the daytime
- Or nighttime (good cause therefore having been shown)

to make a search of the above named or described electronic devices for the herein above described information, and if you find the same or any part thereof to retain such in your custody or in the custody of the agency you represent, as provided by ARS §13-3918.

Given under my hand and dated this 21st day of January 2020

  
 \_\_\_\_\_  
 Judge  
 Of the Maricopa County Superior Court

HONORABLE JAMES P. BUESING  
MARICOPA COUNTY SUPERIOR COURT



**ARIZONA DEPARTMENT OF PUBLIC SAFETY  
RETURN OF SEARCH WARRANT**

Detective G. Linares #7577, a peace officer in the State of Arizona, being duly sworn upon oath, deposes and says:

That on the 22nd day of January, 2020, Detective G. Linares #7577, executed this search warrant, number SW2020-000836, and the following described property or things examined or seized:

- **Pending a physical electronic download of the black CAT Cell Phone belonging to Jonathan David Messare.**

Detective Linares further certifies that the foregoing inventory is true and detailed account of all the property taken by him pursuant to A.R.S. 13-3921. When the download is complete, a copy of the warrant will be left with the electronic device examined.

~~\_\_\_\_\_~~  
 Affiant, Detective G. Linares #7577  
 Arizona Department of Public Safety

SUBSCRIBED AND SWORN TO before me this 22nd day of January, 2020

*[Signature]*  
 Judge  
 of the Maricopa County Superior Court

**HONORABLE GREGORY J. GNEPPER  
MARICOPA COUNTY SUPERIOR COURT**



**ARIZONA DEPARTMENT OF PUBLIC SAFETY  
COLLECTED EVIDENCE RECOVERY LOG**

**DR NUMBER: I20003903**

SCENE ITEM	EVIDENCE ITEM	DESCRIPTION	LOCATION FOUND	TIME
AR1	9341	Black Glock 17 9mm semiautomatic handgun with mounted light (Gun S/N: BEAG443) (Light S/N: C4-4148750514)	Sedona Police Department	01/20/2020 1804
AR2	9336	Black Glock magazine (17 round capacity) with 12 rounds of ammunition in magazine plus one in the chamber (Federal Luger 9mm ammunition)	Sedona Police Department	01/20/2020 1806
AR3	9337	Black Glock magazine (17 round capacity) with 16 rounds of ammunition (Federal Luger 9mm ammunition)	Sedona Police Department	01/20/2020 1812
AR4	9338	Black Glock magazine (17 round capacity) with 16 rounds of ammunition (Federal Luger 9mm ammunition)	Sedona Police Department	01/20/2020 1815
AR5	9342	Black Glock 17 9mm semiautomatic handgun (no light) (S/N: BEAG461)	Sedona Police Department	01/20/2020 1900
AR6	9340	Black Glock magazine (17 round capacity) with 14 rounds of ammunition plus one in the chamber (Federal Luger 9mm ammunition)	Sedona Police Department	01/20/2020 1903
AR7	9339	Black Glock magazine (17 round capacity) with 16 rounds of ammunition (Federal Luger 9mm ammunition)	Sedona Police Department	01/20/2020 1908
AR8	9335	Black Glock magazine (17 round capacity) with 16 rounds of ammunition (Federal Luger 9mm ammunition)	Sedona Police Department	01/20/2020 1911
AR9	21620	CD of Sergeant Pelletier's (Sedona PD) walk through	55 New Castle Lane	01/20/2020 2019

Detective Name	ID No.	Location	Date	Supervisor
Andrew Reed	7325	31030100	01/22/2020	Sergeant Matthew Monaco, #6645



**ARIZONA DEPARTMENT OF PUBLIC SAFETY  
COLLECTED EVIDENCE RECOVERY LOG**

**DR NUMBER: I20003903**

SCENE ITEM	EVIDENCE ITEM	DESCRIPTION	LOCATION FOUND	TIME
AR10	21622	CD of Officer Hunt's (Sedona PD) walk through	55 New Castle Lane	01/20/2020 2030
AR11	21623	CD of Officer Hudspeth's (Sedona PD) walk through	55 New Castle Lane	01/20/2020 2042
AR12	21625	CD containing measurement and diagram data	Received by Detective Sortor, #6400	01/22/2020 1545
AR13	21626	CD containing Interview with Susan Frohman	Received by Detective Gray, #7505	01/23/2020 0830
AR14	21627	USB thumb drive containing SPD CAD records, 911 calls, and SFD run records	Received from SPD Detective Bergstad, #850	01/23/2020 0857
AR15	10084	Gray glove	CCME Office	01/23/2020 1547
AR16	10086	Black lighter and black marker	CCME Office	01/23/2020 1547
AR17	10087	Brown paper evidence bag from M.E.'s office	CCME Office	01/23/2020 1547
AR17.1	10088	Credit card, metal piece, and note	CCME Office	01/23/2020 1547
AR17.2	10091	(1) \$5 bill, (1) nickel, and (3) pennies	CCME Office	01/23/2020 1547
AR17.3	10093	3 ID cards and credit card	CCME Office	01/23/2020 1547
AR18	10096	Black pouch with green leafy substance and pipe	CCME Office	01/23/2020 1547
AR19	10095	Harmonica and pipe	CCME Office	01/23/2020 1547

Detective Name	ID No.	Location	Date	Supervisor
Andrew Reed	7325	31030100	01/22/2020	Sergeant Matthew Monaco, #6645

**ARIZONA DEPARTMENT OF PUBLIC SAFETY  
COLLECTED EVIDENCE RECOVERY LOG****DR NUMBER: I20003903**

SCENE ITEM	EVIDENCE ITEM	DESCRIPTION	LOCATION FOUND	TIME
AR20	10094	Glove	CCME Office	01/23/2020 1547
AR21	10097	Left shoe and sock	CCME Office	01/23/2020 1547
AR22	10098	Right shoe and sock	CCME Office	01/23/2020 1547
AR23	10099	Green pants and brown belt	CCME Office	01/23/2020 1547
AR24	10100	Handcuffs	CCME Office	01/23/2020 1547
AR25	10101	Camouflage vest	CCME Office	01/23/2020 1547
AR26	10102	Green vest	CCME Office	01/23/2020 1547
AR27	10103	Harness	CCME Office	01/23/2020 1547
AR28	10104	Black scarf	CCME Office	01/23/2020 1547
AR29	10105	Brown hat	CCME Office	01/23/2020 1547
AR30	10106	Brown evidence bag	CCME Office	01/23/2020 1547
AR30.1	10107	Two gloves and camouflage mask	CCME Office	01/23/2020 1547
AR30.2	10109	Two clips, , rope, and black pouch	CCME Office	01/23/2020 1547

Detective Name	ID No.	Location	Date	Supervisor
Andrew Reed	7325	31030100	01/22/2020	Sergeant Matthew Monaco, #6645



**ARIZONA DEPARTMENT OF PUBLIC SAFETY  
COLLECTED EVIDENCE RECOVERY LOG**

**DR NUMBER: I20003903**

SCENE ITEM	EVIDENCE ITEM	DESCRIPTION	LOCATION FOUND	TIME
AR30.3	10110	Handcuff key	CCME Office	01/23/2020 1547
AR31	10111	Black knife sheath	CCME Office	01/23/2020 1547
AR32	10112	Two black belt straps	CCME Office	01/23/2020 1547
AR33	10113	Brown bracelet	CCME Office	01/23/2020 1547
AR34	10114	Brown bracelet	CCME Office	01/23/2020 1547
AR35	10115	Pipe and lighter	CCME Office	01/23/2020 1547
AR36	10116	Metal key	CCME Office	01/23/2020 1547
AR37	10117	Messare's fingernail clippings	CCME Office	01/23/2020 1547
AR38	10118	Projectile	CCME Office	01/23/2020 1547
AR39	10120	Projectile	CCME Office	01/23/2020 1547
AR40	10119	Fingerprint Card (Messare)	CCME Office	01/23/2020 1547
AR41	10121	Blood sample	CCME Office	01/23/2020 1547
AR42	10122	Projectile	CCME Office	01/23/2020 1547

Detective Name	ID No.	Location	Date	Supervisor
Andrew Reed	7325	31030100	01/22/2020	Sergeant Matthew Monaco, #6645



**ARIZONA DEPARTMENT OF PUBLIC SAFETY  
COLLECTED EVIDENCE RECOVERY LOG**

**DR NUMBER: I20003903**

SCENE ITEM	EVIDENCE ITEM	DESCRIPTION	LOCATION FOUND	TIME
AR43	10123	Projectile	CCME Office	01/23/2020 1547
AR44	10124	CD with photographs from autopsy	CCME Office	01/23/2020 1547
AR45	21628	CD of audio interview with Hudspeth	1003 North Main Street Cottonwood, AZ	01/30/2020 1139
AR46	21630	CD of audio interview with Hunt	1003 North Main Street Cottonwood, AZ	01/30/2020 1331
AR47	21631	CD of audio interview with Pelletier	1003 North Main Street Cottonwood, AZ	01/30/2020 1434
AR48	21633	CD of audio interview with Charlie Koon	Prescott, Arizona	02/27/2020 1000
AR49	21634	CD containing Messare's phone SD download	Arizona Department of Public Safety	04/16/2020 0915
AR50	21635	USB Thumb drive and CD with autopsy photographs (2 <sup>nd</sup> Copy)	CCME Office	01/23/2020 1547

Detective Name	ID No.	Location	Date	Supervisor
Andrew Reed	7325	31030100	01/22/2020	Sergeant Matthew Monaco, #6645

**SEARCH WARRANT RECEIPT / EVIDENCE LIST**

DR NUMBER I20003903	
ENTRY TIME 9:56PM	EXIT TIME 12:02AM

TODAY'S DATE:		RECORDER BADGE NO.	AFFIANT / OFFICER		SEARCH WARRANT ADDRESS
01/20/2020		J. Ruble, #5627	G. Linares, #7577		55 Newcastle Lane Sedona Arizona
ITEM NO.	TIME FOUND	ITEM FOUND BY:	BADGE NO.	DESCRIPTION	LOCATION
MV1	2157	Van Tassel	07809	1 pair Black Nitrile Gloves	Behind Vehicle #14
MV2	2158	Van Tassel	07809	Shell Casing, FC 9MM Lugar	North of Vehicle #15
MV3	2159	Van Tassel	07809	Shell Casing, FC 9MM Lugar	North of Vehicle #15
MV4	2200	Van Tassel	07809	Shell Casing, FC 9MM Lugar	North of Vehicle #15
MV5	2201	Van Tassel	07809	Shell Casing, FC 9MM Lugar	North of Vehicle #15
MV6	2202	Van Tassel	07809	Shell Casing, FC 9MM Lugar	North of Vehicle #15
MV7	2203	Van Tassel	07809	Shell Casing, FC 9MM Lugar	North of Vehicle #15
MV8	2204	Van Tassel	07809	4 Loose gloves next to box	Northeast of Vehicle #15
MV9	2207	Van Tassel	07809	ECG Electro Bag	South of Vehicle #12
MV10	2208	Van Tassel	07809	Sun Glasses (Kaenon)	Southeast of Vehicle #12
MV11	2209	Van Tassel	07809	Walking Stick w/ Pouch & 2 green balls	East of deceased subject
MV12	2312	Van Tassel	07809	Deceased Male	On ground of inner perimeter
MVA.1	2229	Van Tassel	07809	L3 Disc	From Vehicle #15
MVB.1	2239	Van Tassel	07809	PNY 32gb SD Card	From Vehicle #7
MVB.2	2249	Van Tassel	07809	Oregon DL A874956	On top of Hood of Vehicle #7
MVB.3	2259	Van Tassel	07809	1 pair Black Nitrile Gloves	Behind Vehicle #7 on the ground
MVB.4	2300	Van Tassel	07809	Red Buck Knife w/ Wood Handle	Rear Cargo area of Vehicle #7
MVB.5	2302	Van Tassel	07809	Hatchet w/ case	Rear Cargo area of Vehicle #7
MVB.6	2304	Van Tassel	07809	Sword	Rear Cargo area of Vehicle #7

CASE AGENT NAME A. Reed	BADGE NO. 07325	RETAINER NAME: Van Tassel	BADGE NO. 07809
----------------------------	--------------------	------------------------------	--------------------

**DISTRIBUTION:** COPY 1 - COURT COPY 2 - OFFICER COPY 3 - RECEIPT





# SEARCH WARRANT RECEIPT / EVIDENCE LIST

DR NUMBER I20003903	
ENTRY TIME 9:56PM	EXIT TIME 12:02AM

TODAY'S DATE: 01/20/2020		RECORDER BADGE NO. J. Ruble, #5627	AFFIANT / OFFICER G. Linares, #7577	SEARCH WARRANT ADDRESS 55 Newcastle Lane, Sedona Arizona	
ITEM NO.	TIME FOUND	ITEM FOUND BY:	BADGE NO.	DESCRIPTION	LOCATION
MVB.7	2306	Van Tassel	07809	White Sheet that contained MVB.4 - 7	Rear Cargo area of Vehicle #7
MVA.2	2322	Van Tassel	07809	EKG Printout	Front Seat of Vehicle #15
MVC.1	2326	Van Tassel	07809	SN #CF0231739	From Vehicle #14
MV12.1	2357	Van Tassel	07809	White Blanket	Covering Deceased

CASE AGENT NAME A. Reed	BADGE NO. 07325	RETAINER NAME: Van Tassel	BADGE NO. 07809
----------------------------	--------------------	------------------------------	--------------------

**DISTRIBUTION:** COPY 1 - COURT COPY 2 - OFFICER COPY 3 - RECEIPT



# SEARCH WARRANT RECEIPT / EVIDENCE LIST

DR NUMBER 120003903	
ENTRY TIME 2021	EXIT TIME 2054

TODAY'S DATE: 01/20/2020		RECORDER BADGE NO. S. Harris, #7575	AFFIANT / OFFICER G. Linares, #7577		SEARCH WARRANT ADDRESS 71 B Newcastle Lane Sedona, Arizona
ITEM NO.	TIME FOUND	ITEM FOUND BY:	BADGE NO.	DESCRIPTION	LOCATION
GL1	2049	S. Harris	07575	Black Cellular Phone	Shelf in Living Room

CASE AGENT NAME A. Reed	BADGE NO. 07325	RETAINER NAME: G. Linares	BADGE NO. 07577
----------------------------	--------------------	------------------------------	--------------------

**DISTRIBUTION:** COPY 1 - COURT COPY 2 - OFFICER COPY 3 - RECEIPT



**ARIZONA DEPARTMENT OF PUBLIC SAFETY**  
**COLLECTED EVIDENCE RECOVERY LOG**

**DR NUMBER:** I20003903

ITEM	DESCRIPTION	LOCATION FOUND	TIME
JF1	One Thumb drive containing dash cam video	From patrol vehicles	01/27/20 1009hrs

Detective Name	ID No.	Location	Date	Supervisor
Justin Fyfe	7460	31030100	01/27/2020	Sergeant Matthew Monaco, 6645



### ARIZONA DEPARTMENT OF PUBLIC SAFETY COLLECTED EVIDENCE RECOVERY LOG

**DR NUMBER:** I20003903

Detective Name	ID No.	Location	Date	Supervisor
Justin Fyfe	7460	31030100	01/27/2020	Sergeant Matthew Monaco, 6645



# ARIZONA DEPT OF PUBLIC SAFETY

## Scientific Analysis Request and Evidence Inventory

DR Number:

**120003903**

Reporting Trooper: REED, ANDY

Badge Number: 7325

### Incident

Incident Nature OFFICER INVOLVED SHOOTING	Address sedona	Contact	Disposition ACTIVE	Locator Code 31030100	Disposition Date 01/20/2020	Judicial Status
---	-------------------	---------	-----------------------	--------------------------	--------------------------------	-----------------

### Evidence

Packaging	Item #	m #	Itemization, description, and serial number	Owner	Requests for analysis
Envelope	10191	JF1	Disk Drive: 1 Count		<input type="checkbox"/> BA <input type="checkbox"/> TOX <input type="checkbox"/> CS <input type="checkbox"/> DNA <input type="checkbox"/> F/T <input type="checkbox"/> LP <input type="checkbox"/> QD <input type="checkbox"/> CFU <small> <input type="checkbox"/>BLOOD <input type="checkbox"/>ALCOHOLICS <input type="checkbox"/>CONTROLLED SUBSTANCES <input type="checkbox"/>DNA <input type="checkbox"/>DNA SEROLOGY <input type="checkbox"/>FIREARMS AND TRAILS <input type="checkbox"/>LATENT PRINTS <input type="checkbox"/>QUESTIONED DOCUMENTS <input type="checkbox"/>TOXICOLOGY <input type="checkbox"/>COMPUTER FORENSICS                 </small>

THIS EVIDENCE MAY IMMEDIATELY BE DESTROYED Signature of Trooper Authorizing Destruction \_\_\_\_\_ Date \_\_\_\_\_

### Chain of Custody

PACKAGE(S)/ITEM(S)	FROM NAME	FROM NO.	TO NAME	TO NO.	PURPOSE	DATE/TIME
10191	J. RIFE	7460	REED	11054	FEI	1-28-20 1530



ARIZONA DEPARTMENT OF PUBLIC SAFETY  
OUTBOUND EVIDENCE TRANSFER RECEIPT

**EVIDENCE TRANSFER TRANSACTION**

Evidence Relinquished By: <b>MICHAEL RUIZ, #5489</b>	Agency: Central Regional Crime Laboratory  <input checked="" type="checkbox"/> <b>PIN Entered</b>
Evidence Received By: <b>FYFE, #7460, JUSTIN</b>	Agency: Arizona Department of Public Safety  <input checked="" type="checkbox"/> <b>PIN Entered</b>
VIA: Note:	
Date & Time: <b>1/22/20 8:36 am</b>	

<u>Agency Case #</u>	<u>Lab Case #</u>	<u>Evidence #</u>	<u>Evidence Description</u>
I20003903	I20003903	CRCL11	Env/ (9327) disk drive
I20003903	I20003903	CRCL13	Env/ (9329) disk drive
I20003903	I20003903	CRCL16	Env/ (9332) disk drive

**Total Package Count: 3**  
**Agency Case Count: 1**



ARIZONA DEPARTMENT OF PUBLIC SAFETY  
INBOUND EVIDENCE RECEIPT

**SUBMISSION INFORMATION**

Evidence Relinquished By: <b>FYFE, #7460, JUSTIN</b>	<b>Agency:</b> Arizona Department of Public Safety <input checked="" type="checkbox"/> <b>PIN Entered</b>
Evidence Received By: <del>JOSEPH TRIPOLI</del> <i>Ron Miles Tatz</i>	<b>Agency:</b> Central Regional Crime Laboratory <input checked="" type="checkbox"/> <b>PIN Entered</b>
Date & Time: <b>01/23/2020 08:13</b>	

<u>Agency Case #</u>	<u>Agency Evid #</u>	<u>Lab Case #</u>	<u>Description</u>
I20003903		I20003903	Env/ (9327) disk drive
I20003903		I20003903	Env/ (9329) disk drive
I20003903		I20003903	Env/ (9332) disk drive

**Total Package Count: 3**



**ARIZONA DEPARTMENT OF PUBLIC SAFETY  
CASE CHAIN OF CUSTODY REPORT  
Laboratory Case #: I20003903**

**ITEM # / DESCRIPTION: CRCL01**

**Env/ (9310) glove**

<u>Date</u>	<u>Time</u>	<u>PIN</u>	<u>From</u>		<u>PIN</u>	<u>To</u>		<u>Note</u>
1/22/20	8:04 am	[ ]	P&E Intake	CRCL	[X]	RUIZ, MICHAEL	CRCL	
1/22/20	8:04 am	[X]	RUIZ, MICHAEL	CRCL	[ ]	803-2020	CRCL	

**ITEM # / DESCRIPTION: CRCL02**

**Env/ (9313) casing**

<u>Date</u>	<u>Time</u>	<u>PIN</u>	<u>From</u>		<u>PIN</u>	<u>To</u>		<u>Note</u>
1/22/20	8:04 am	[ ]	P&E Intake	CRCL	[X]	RUIZ, MICHAEL	CRCL	
1/22/20	8:04 am	[X]	RUIZ, MICHAEL	CRCL	[ ]	803-2020	CRCL	
1/27/20	10:54 am	[ ]	803-2020	CRCL	[X]	MILES, RON	CRCL	
1/27/20	10:54 am	[X]	MILES, RON	CRCL	[X]	VAN TASSEL, #7809, MISTY	Arizona Department of Public Safety	
1/27/20	11:34 am	[X]	VAN TASSEL, #7809, MISTY	Arizona Department of Public Safety	[X]	RUIZ, MICHAEL	CRCL	
1/27/20	11:34 am	[X]	RUIZ, MICHAEL	CRCL	[ ]	803-2020	CRCL	

**ITEM # / DESCRIPTION: CRCL03**

**Env/ (9315) casing**

<u>Date</u>	<u>Time</u>	<u>PIN</u>	<u>From</u>		<u>PIN</u>	<u>To</u>		<u>Note</u>
1/22/20	8:04 am	[ ]	P&E Intake	CRCL	[X]	RUIZ, MICHAEL	CRCL	
1/22/20	8:04 am	[X]	RUIZ, MICHAEL	CRCL	[ ]	803-2020	CRCL	
1/27/20	10:54 am	[ ]	803-2020	CRCL	[X]	MILES, RON	CRCL	
1/27/20	10:54 am	[X]	MILES, RON	CRCL	[X]	VAN TASSEL, #7809, MISTY	Arizona Department of Public Safety	
1/27/20	11:34 am	[X]	VAN TASSEL, #7809, MISTY	Arizona Department of Public Safety	[X]	RUIZ, MICHAEL	CRCL	
1/27/20	11:34 am	[X]	RUIZ, MICHAEL	CRCL	[ ]	803-2020	CRCL	

**ITEM # / DESCRIPTION: CRCL04**

**Env/ (9316) casing**

<u>Date</u>	<u>Time</u>	<u>PIN</u>	<u>From</u>		<u>PIN</u>	<u>To</u>		<u>Note</u>
1/22/20	8:04 am	[ ]	P&E Intake	CRCL	[X]	RUIZ, MICHAEL	CRCL	
1/22/20	8:04 am	[X]	RUIZ, MICHAEL	CRCL	[ ]	803-2020	CRCL	
1/27/20	10:54 am	[ ]	803-2020	CRCL	[X]	MILES, RON	CRCL	
1/27/20	10:54 am	[X]	MILES, RON	CRCL	[X]	VAN TASSEL, #7809, MISTY	Arizona Department of Public Safety	
1/27/20	11:34 am	[X]	VAN TASSEL, #7809, MISTY	Arizona Department of Public Safety	[X]	RUIZ, MICHAEL	CRCL	
1/27/20	11:34 am	[X]	RUIZ, MICHAEL	CRCL	[ ]	803-2020	CRCL	

**ITEM # / DESCRIPTION: CRCL05**

**Env/ (9318) casing**

<u>Date</u>	<u>Time</u>	<u>PIN</u>	<u>From</u>		<u>PIN</u>	<u>To</u>		<u>Note</u>
1/22/20	8:04 am	[ ]	P&E Intake	CRCL	[X]	RUIZ, MICHAEL	CRCL	
1/22/20	8:04 am	[X]	RUIZ, MICHAEL	CRCL	[ ]	803-2020	CRCL	

Item #: CRCL05 Continued on next page

DPS000320

[X] indicates a PIN was entered  
\* indicates an update was performed





**ARIZONA DEPARTMENT OF PUBLIC SAFETY**  
**CASE CHAIN OF CUSTODY REPORT**  
 Laboratory Case #: I20003903

**Chain of Custody continued for Item#:CRCL05**

1/27/20	10:54 am	<input type="checkbox"/>	803-2020	CRCL	<input checked="" type="checkbox"/>	MILES, RON	CRCL
1/27/20	10:54 am	<input checked="" type="checkbox"/>	MILES, RON	CRCL	<input checked="" type="checkbox"/>	VAN TASSEL, #7809, MISTY	Arizona Department of Public Safety
1/27/20	11:34 am	<input checked="" type="checkbox"/>	VAN TASSEL, #7809, MISTY	Arizona Department of Public Safety	<input checked="" type="checkbox"/>	RUIZ, MICHAEL	CRCL
1/27/20	11:34 am	<input checked="" type="checkbox"/>	RUIZ, MICHAEL	CRCL	<input type="checkbox"/>	803-2020	CRCL

**ITEM # / DESCRIPTION: CRCL06**

**Env/ (9319) casing**

<u>Date</u>	<u>Time</u>	<u>PIN</u>	<u>From</u>		<u>PIN</u>	<u>To</u>	<u>Note</u>
1/22/20	8:04 am	<input type="checkbox"/>	P&E Intake	CRCL	<input checked="" type="checkbox"/>	RUIZ, MICHAEL	CRCL
1/22/20	8:04 am	<input checked="" type="checkbox"/>	RUIZ, MICHAEL	CRCL	<input type="checkbox"/>	803-2020	CRCL
1/27/20	10:54 am	<input type="checkbox"/>	803-2020	CRCL	<input checked="" type="checkbox"/>	MILES, RON	CRCL
1/27/20	10:54 am	<input checked="" type="checkbox"/>	MILES, RON	CRCL	<input checked="" type="checkbox"/>	VAN TASSEL, #7809, MISTY	Arizona Department of Public Safety
1/27/20	11:34 am	<input checked="" type="checkbox"/>	VAN TASSEL, #7809, MISTY	Arizona Department of Public Safety	<input checked="" type="checkbox"/>	RUIZ, MICHAEL	CRCL
1/27/20	11:34 am	<input checked="" type="checkbox"/>	RUIZ, MICHAEL	CRCL	<input type="checkbox"/>	803-2020	CRCL

**ITEM # / DESCRIPTION: CRCL07**

**Env/ (9320) casing**

<u>Date</u>	<u>Time</u>	<u>PIN</u>	<u>From</u>		<u>PIN</u>	<u>To</u>	<u>Note</u>
1/22/20	8:04 am	<input type="checkbox"/>	P&E Intake	CRCL	<input checked="" type="checkbox"/>	RUIZ, MICHAEL	CRCL
1/22/20	8:04 am	<input checked="" type="checkbox"/>	RUIZ, MICHAEL	CRCL	<input type="checkbox"/>	803-2020	CRCL

**ITEM # / DESCRIPTION: CRCL08**

**Env/ (9321) glove**

<u>Date</u>	<u>Time</u>	<u>PIN</u>	<u>From</u>		<u>PIN</u>	<u>To</u>	<u>Note</u>
1/22/20	8:04 am	<input type="checkbox"/>	P&E Intake	CRCL	<input checked="" type="checkbox"/>	RUIZ, MICHAEL	CRCL
1/22/20	8:04 am	<input checked="" type="checkbox"/>	RUIZ, MICHAEL	CRCL	<input type="checkbox"/>	803-2020	CRCL

**ITEM # / DESCRIPTION: CRCL09**

**Env/ (9323) package**

<u>Date</u>	<u>Time</u>	<u>PIN</u>	<u>From</u>		<u>PIN</u>	<u>To</u>	<u>Note</u>
1/22/20	8:04 am	<input type="checkbox"/>	P&E Intake	CRCL	<input checked="" type="checkbox"/>	RUIZ, MICHAEL	CRCL
1/22/20	8:04 am	<input checked="" type="checkbox"/>	RUIZ, MICHAEL	CRCL	<input type="checkbox"/>	803-2020	CRCL

**ITEM # / DESCRIPTION: CRCL10**

**PKG/ (9326) rebar cane**

<u>Date</u>	<u>Time</u>	<u>PIN</u>	<u>From</u>		<u>PIN</u>	<u>To</u>	<u>Note</u>
1/22/20	8:04 am	<input type="checkbox"/>	P&E Intake	CRCL	<input checked="" type="checkbox"/>	RUIZ, MICHAEL	CRCL
1/22/20	8:04 am	<input checked="" type="checkbox"/>	RUIZ, MICHAEL	CRCL	<input type="checkbox"/>	LABORATORY STAGING SHELVES	CRCL
1/22/20	9:06 am	<input type="checkbox"/>	LABORATORY STAGING SHELVES	CRCL	<input checked="" type="checkbox"/>	AFTOSMES, CARL	CRCL
1/22/20	9:06 am	<input checked="" type="checkbox"/>	AFTOSMES, CARL	CRCL	<input type="checkbox"/>	4000A	CRCL

**ITEM # / DESCRIPTION: CRCL11**

**Env/ (9327) disk drive**

Item #: CRCL11 Continued on next page

[X] indicates a PIN was entered  
 \* indicates an update was performed



**ARIZONA DEPARTMENT OF PUBLIC SAFETY**  
**CASE CHAIN OF CUSTODY REPORT**  
 Laboratory Case #: I20003903

**Chain of Custody continued for Item#:CRCL11**

<u>Date</u>	<u>Time</u>	<u>PIN</u>	<u>From</u>		<u>PIN</u>	<u>To</u>		<u>Note</u>
1/22/20	8:04 am	[ ]	P&E Intake	CRCL	[X]	RUIZ, MICHAEL	CRCL	
1/22/20	8:04 am	[X]	RUIZ, MICHAEL	CRCL	[ ]	803-2020	CRCL	
1/22/20	8:36 am	[ ]	803-2020	CRCL	[X]	RUIZ, MICHAEL	CRCL	
1/22/20	8:36 am	[X]	RUIZ, MICHAEL	CRCL	[X]	FYFE, #7460, JUSTIN	Arizona Department of Public Safety	
1/23/20	8:13 am	[X]	FYFE, #7460, JUSTIN	Arizona Department of Public Safety	[X]	MILES, RON	CRCL	
1/23/20	8:13 am	[X]	MILES, RON	CRCL	[ ]	803-2020	CRCL	

**ITEM # / DESCRIPTION: CRCL12**

**Env/ (9328) paper**

<u>Date</u>	<u>Time</u>	<u>PIN</u>	<u>From</u>		<u>PIN</u>	<u>To</u>		<u>Note</u>
1/22/20	8:04 am	[ ]	P&E Intake	CRCL	[X]	RUIZ, MICHAEL	CRCL	
1/22/20	8:04 am	[X]	RUIZ, MICHAEL	CRCL	[ ]	803-2020	CRCL	

**ITEM # / DESCRIPTION: CRCL13**

**Env/ (9329) disk drive**

<u>Date</u>	<u>Time</u>	<u>PIN</u>	<u>From</u>		<u>PIN</u>	<u>To</u>		<u>Note</u>
1/22/20	8:04 am	[ ]	P&E Intake	CRCL	[X]	RUIZ, MICHAEL	CRCL	
1/22/20	8:04 am	[X]	RUIZ, MICHAEL	CRCL	[ ]	803-2020	CRCL	
1/22/20	8:36 am	[ ]	803-2020	CRCL	[X]	RUIZ, MICHAEL	CRCL	
1/22/20	8:36 am	[X]	RUIZ, MICHAEL	CRCL	[X]	FYFE, #7460, JUSTIN	Arizona Department of Public Safety	
1/23/20	8:13 am	[X]	FYFE, #7460, JUSTIN	Arizona Department of Public Safety	[X]	MILES, RON	CRCL	
1/23/20	8:13 am	[X]	MILES, RON	CRCL	[ ]	803-2020	CRCL	

**ITEM # / DESCRIPTION: CRCL14**

**Env/ (9330) Drivers license**

<u>Date</u>	<u>Time</u>	<u>PIN</u>	<u>From</u>		<u>PIN</u>	<u>To</u>		<u>Note</u>
1/22/20	8:04 am	[ ]	P&E Intake	CRCL	[X]	RUIZ, MICHAEL	CRCL	
1/22/20	8:04 am	[X]	RUIZ, MICHAEL	CRCL	[ ]	803-2020	CRCL	

**ITEM # / DESCRIPTION: CRCL15**

**Env/ (9331) glove**

<u>Date</u>	<u>Time</u>	<u>PIN</u>	<u>From</u>		<u>PIN</u>	<u>To</u>		<u>Note</u>
1/22/20	8:04 am	[ ]	P&E Intake	CRCL	[X]	RUIZ, MICHAEL	CRCL	
1/22/20	8:04 am	[X]	RUIZ, MICHAEL	CRCL	[ ]	803-2020	CRCL	

**ITEM # / DESCRIPTION: CRCL16**

**Env/ (9332) disk drive**

<u>Date</u>	<u>Time</u>	<u>PIN</u>	<u>From</u>		<u>PIN</u>	<u>To</u>		<u>Note</u>
1/22/20	8:04 am	[ ]	P&E Intake	CRCL	[X]	RUIZ, MICHAEL	CRCL	
1/22/20	8:04 am	[X]	RUIZ, MICHAEL	CRCL	[ ]	803-2020	CRCL	
1/22/20	8:36 am	[ ]	803-2020	CRCL	[X]	RUIZ, MICHAEL	CRCL	
1/22/20	8:36 am	[X]	RUIZ, MICHAEL	CRCL	[X]	FYFE, #7460, JUSTIN	Arizona Department of Public Safety	

Item #: CRCL16 Continued on next page

[X] indicates a PIN was entered  
 \* indicates an update was performed



**ARIZONA DEPARTMENT OF PUBLIC SAFETY**  
**CASE CHAIN OF CUSTODY REPORT**  
 Laboratory Case #: I20003903

**Chain of Custody continued for Item#:CRCL16**

1/23/20	8:13 am	<input checked="" type="checkbox"/>	FYFE, #7460, JUSTIN	Arizona Department of Public Safety	<input checked="" type="checkbox"/>	MILES, RON	CRCL
1/23/20	8:13 am	<input checked="" type="checkbox"/>	MILES, RON	CRCL	<input type="checkbox"/>	803-2020	CRCL

**ITEM # / DESCRIPTION: CRCL17**

**Box/ (9333) bed sheet**

<u>Date</u>	<u>Time</u>	<u>PIN</u>	<u>From</u>		<u>PIN</u>	<u>To</u>	<u>Note</u>
1/22/20	8:04 am	<input type="checkbox"/>	P&E Intake	CRCL	<input checked="" type="checkbox"/>	RUIZ, MICHAEL	CRCL
1/22/20	8:04 am	<input checked="" type="checkbox"/>	RUIZ, MICHAEL	CRCL	<input type="checkbox"/>	803-2020	CRCL
1/22/20	3:22 pm	<input type="checkbox"/>	803-2020	CRCL	<input checked="" type="checkbox"/>	RUIZ, MICHAEL	CRCL
1/22/20	3:22 pm	<input checked="" type="checkbox"/>	RUIZ, MICHAEL	CRCL	<input type="checkbox"/>	D5	CRCL
1/31/20	3:19 pm	<input type="checkbox"/>	D5	CRCL	<input checked="" type="checkbox"/>	KILLION, MATHEW	CRCL
1/31/20	3:19 pm	<input checked="" type="checkbox"/>	KILLION, MATHEW	CRCL	<input type="checkbox"/>	DSB38	CRCL

**ITEM # / DESCRIPTION: CRCL18**

**Env/ (9334) cell phone**

<u>Date</u>	<u>Time</u>	<u>PIN</u>	<u>From</u>		<u>PIN</u>	<u>To</u>	<u>Note</u>
1/22/20	8:04 am	<input type="checkbox"/>	P&E Intake	CRCL	<input checked="" type="checkbox"/>	RUIZ, MICHAEL	CRCL
1/22/20	8:04 am	<input checked="" type="checkbox"/>	RUIZ, MICHAEL	CRCL	<input type="checkbox"/>	803-2020	CRCL
2/27/20	12:52 pm	<input type="checkbox"/>	803-2020	CRCL	<input checked="" type="checkbox"/>	MILES, RON	CRCL
2/27/20	12:52 pm	<input checked="" type="checkbox"/>	MILES, RON	CRCL	<input checked="" type="checkbox"/>	EASTON, #6115, JEFFREY	Arizona Department of Public Safety
4/20/20	1:56 pm	<input checked="" type="checkbox"/>	OLSZAK, #5625, THOMAS M	Arizona Department of Public Safety	<input checked="" type="checkbox"/>	KILLION, MATHEW	CRCL
4/20/20	1:56 pm	<input checked="" type="checkbox"/>	KILLION, MATHEW	CRCL	<input type="checkbox"/>	803-2020	CRCL

**ITEM # / DESCRIPTION: CRCL19**

**Env/ (9335) ammo**

<u>Date</u>	<u>Time</u>	<u>PIN</u>	<u>From</u>		<u>PIN</u>	<u>To</u>	<u>Note</u>
1/22/20	8:04 am	<input type="checkbox"/>	P&E Intake	CRCL	<input checked="" type="checkbox"/>	RUIZ, MICHAEL	CRCL
1/22/20	8:04 am	<input checked="" type="checkbox"/>	RUIZ, MICHAEL	CRCL	<input type="checkbox"/>	803-2020	CRCL

**ITEM # / DESCRIPTION: CRCL20**

**Env/ (9336) ammo**

<u>Date</u>	<u>Time</u>	<u>PIN</u>	<u>From</u>		<u>PIN</u>	<u>To</u>	<u>Note</u>
1/22/20	8:04 am	<input type="checkbox"/>	P&E Intake	CRCL	<input checked="" type="checkbox"/>	RUIZ, MICHAEL	CRCL
1/22/20	8:04 am	<input checked="" type="checkbox"/>	RUIZ, MICHAEL	CRCL	<input type="checkbox"/>	803-2020	CRCL

**ITEM # / DESCRIPTION: CRCL21**

**Env/ (9337) ammo**

<u>Date</u>	<u>Time</u>	<u>PIN</u>	<u>From</u>		<u>PIN</u>	<u>To</u>	<u>Note</u>
1/22/20	8:04 am	<input type="checkbox"/>	P&E Intake	CRCL	<input checked="" type="checkbox"/>	RUIZ, MICHAEL	CRCL
1/22/20	8:04 am	<input checked="" type="checkbox"/>	RUIZ, MICHAEL	CRCL	<input type="checkbox"/>	803-2020	CRCL

**ITEM # / DESCRIPTION: CRCL22**

**Env/ (9338) ammo**

<u>Date</u>	<u>Time</u>	<u>PIN</u>	<u>From</u>		<u>PIN</u>	<u>To</u>	<u>Note</u>
-------------	-------------	------------	-------------	--	------------	-----------	-------------

Item #: CRCL22 Continued on next page

DPS000323

**[X] indicates a PIN was entered**  
**\* indicates an update was performed**



**ARIZONA DEPARTMENT OF PUBLIC SAFETY**  
**CASE CHAIN OF CUSTODY REPORT**  
 Laboratory Case #: I20003903

**Chain of Custody continued for Item#:CRCL22**

1/22/20	8:04 am	<input type="checkbox"/>	P&E Intake	CRCL	<input checked="" type="checkbox"/>	RUIZ, MICHAEL	CRCL
1/22/20	8:04 am	<input checked="" type="checkbox"/>	RUIZ, MICHAEL	CRCL	<input type="checkbox"/>	803-2020	CRCL

**ITEM # / DESCRIPTION: CRCL23**

**Env/ (9339) ammo**

<u>Date</u>	<u>Time</u>	<u>PIN</u>	<u>From</u>		<u>PIN</u>	<u>To</u>	<u>Note</u>
1/22/20	8:04 am	<input type="checkbox"/>	P&E Intake	CRCL	<input checked="" type="checkbox"/>	RUIZ, MICHAEL	CRCL
1/22/20	8:04 am	<input checked="" type="checkbox"/>	RUIZ, MICHAEL	CRCL	<input type="checkbox"/>	803-2020	CRCL

**ITEM # / DESCRIPTION: CRCL24**

**Env/ (9340) ammo**

<u>Date</u>	<u>Time</u>	<u>PIN</u>	<u>From</u>		<u>PIN</u>	<u>To</u>	<u>Note</u>
1/22/20	8:04 am	<input type="checkbox"/>	P&E Intake	CRCL	<input checked="" type="checkbox"/>	RUIZ, MICHAEL	CRCL
1/22/20	8:04 am	<input checked="" type="checkbox"/>	RUIZ, MICHAEL	CRCL	<input type="checkbox"/>	803-2020	CRCL

**ITEM # / DESCRIPTION: CRCL25**

**Box/ (9341) Glock 9mm pistol**

<u>Date</u>	<u>Time</u>	<u>PIN</u>	<u>From</u>		<u>PIN</u>	<u>To</u>	<u>Note</u>
1/22/20	8:04 am	<input type="checkbox"/>	P&E Intake	CRCL	<input checked="" type="checkbox"/>	RUIZ, MICHAEL	CRCL
1/22/20	8:04 am	<input checked="" type="checkbox"/>	RUIZ, MICHAEL	CRCL	<input type="checkbox"/>	SAFETY CHECK - CRCL	CRCL
2/4/20	8:23 am	<input type="checkbox"/>	SAFETY CHECK - CRCL	CRCL	<input checked="" type="checkbox"/>	TRIPOLI, JOSEPH	CRCL
2/4/20	8:23 am	<input checked="" type="checkbox"/>	TRIPOLI, JOSEPH	CRCL	<input type="checkbox"/>	CRCL Firearms Evidence Room (A152)	CRCL
2/4/20	8:30 am	<input type="checkbox"/>	CRCL Firearms Evidence Room (A152)	CRCL	<input checked="" type="checkbox"/>	MOBERG, JEFF	CRCL safety check
2/4/20	9:02 am	<input checked="" type="checkbox"/>	MOBERG, JEFF	CRCL	<input type="checkbox"/>	CRCL Firearms Evidence Room (A152)	CRCL
2/5/20	7:26 am	<input type="checkbox"/>	CRCL Firearms Evidence Room (A152)	CRCL	<input checked="" type="checkbox"/>	AFTOSMES, CARL	CRCL
2/5/20	7:26 am	<input checked="" type="checkbox"/>	AFTOSMES, CARL	CRCL	<input type="checkbox"/>	HG BOXES 2	CRCL
4/1/20	9:11 am	<input type="checkbox"/>	HG BOXES 2	CRCL	<input checked="" type="checkbox"/>	LICANO, PAUL	CRCL
4/1/20	9:11 am	<input checked="" type="checkbox"/>	LICANO, PAUL	CRCL	<input type="checkbox"/>	CRCL Firearms Evidence Room (A152)	CRCL
4/13/20	7:40 am	<input type="checkbox"/>	CRCL Firearms Evidence Room (A152)	CRCL	<input checked="" type="checkbox"/>	FORD, JARED	CRCL
4/13/20	8:02 am	<input checked="" type="checkbox"/>	FORD, JARED	CRCL	<input type="checkbox"/>	CRCL Firearms Evidence Room (A152)	CRCL
4/13/20	1:28 pm	<input type="checkbox"/>	CRCL Firearms Evidence Room (A152)	CRCL	<input checked="" type="checkbox"/>	LICANO, PAUL	CRCL
4/13/20	1:28 pm	<input checked="" type="checkbox"/>	LICANO, PAUL	CRCL	<input type="checkbox"/>	HG BOXES 4	CRCL

**ITEM # : 9341**

**Outer Package #: CRCL25**

<u>Date</u>	<u>Time</u>	<u>PIN</u>	<u>From</u>		<u>PIN</u>	<u>To</u>	<u>Note</u>
1/22/20	8:04 am	<input type="checkbox"/>	P&E Intake	CRCL	<input checked="" type="checkbox"/>	RUIZ, MICHAEL	CRCL

**Item #: 9341 Continued on next page**

DPS000324

**[X] indicates a PIN was entered**  
**\* indicates an update was performed**



**ARIZONA DEPARTMENT OF PUBLIC SAFETY  
CASE CHAIN OF CUSTODY REPORT  
Laboratory Case #: I20003903**

**Chain of Custody continued for Item#:9341**

1/22/20	8:04 am	<input checked="" type="checkbox"/>	RUIZ, MICHAEL	CRCL	<input type="checkbox"/>	SAFETY CHECK - CRCL	CRCL	
2/4/20	8:23 am	<input type="checkbox"/>	SAFETY CHECK - CRCL	CRCL	<input checked="" type="checkbox"/>	TRIPOLI, JOSEPH	CRCL	
2/4/20	8:23 am	<input checked="" type="checkbox"/>	TRIPOLI, JOSEPH	CRCL	<input type="checkbox"/>	CRCL Firearms Evidence Room (A152)	CRCL	
2/4/20	8:30 am	<input type="checkbox"/>	CRCL Firearms Evidence Room (A152)	CRCL	<input checked="" type="checkbox"/>	MOBERG, JEFF	CRCL	safety check
2/4/20	9:02 am	<input checked="" type="checkbox"/>	MOBERG, JEFF	CRCL	<input type="checkbox"/>	CRCL Firearms Evidence Room (A152)	CRCL	
2/5/20	7:26 am	<input type="checkbox"/>	CRCL Firearms Evidence Room (A152)	CRCL	<input checked="" type="checkbox"/>	AFTOSMES, CARL	CRCL	
2/5/20	7:26 am	<input checked="" type="checkbox"/>	AFTOSMES, CARL	CRCL	<input type="checkbox"/>	HG BOXES 2	CRCL	
4/1/20	9:11 am	<input type="checkbox"/>	HG BOXES 2	CRCL	<input checked="" type="checkbox"/>	LICANO, PAUL	CRCL	
4/1/20	9:11 am	<input checked="" type="checkbox"/>	LICANO, PAUL	CRCL	<input type="checkbox"/>	CRCL Firearms Evidence Room (A152)	CRCL	
4/13/20	7:40 am	<input type="checkbox"/>	CRCL Firearms Evidence Room (A152)	CRCL	<input checked="" type="checkbox"/>	FORD, JARED	CRCL	
4/13/20	8:02 am	<input checked="" type="checkbox"/>	FORD, JARED	CRCL	<input type="checkbox"/>	CRCL Firearms Evidence Room (A152)	CRCL	
4/13/20	1:28 pm	<input type="checkbox"/>	CRCL Firearms Evidence Room (A152)	CRCL	<input checked="" type="checkbox"/>	LICANO, PAUL	CRCL	
4/13/20	1:28 pm	<input checked="" type="checkbox"/>	LICANO, PAUL	CRCL	<input type="checkbox"/>	HG BOXES 4	CRCL	

**ITEM # / DESCRIPTION: CRCL26**

**Box/ (9342) Glock 9mm pistol**

Date	Time	PIN	From		PIN	To		Note
1/22/20	8:04 am	<input type="checkbox"/>	P&E Intake	CRCL	<input checked="" type="checkbox"/>	RUIZ, MICHAEL	CRCL	
1/22/20	8:04 am	<input checked="" type="checkbox"/>	RUIZ, MICHAEL	CRCL	<input type="checkbox"/>	SAFETY CHECK - CRCL	CRCL	
2/4/20	8:23 am	<input type="checkbox"/>	SAFETY CHECK - CRCL	CRCL	<input checked="" type="checkbox"/>	TRIPOLI, JOSEPH	CRCL	
2/4/20	8:23 am	<input checked="" type="checkbox"/>	TRIPOLI, JOSEPH	CRCL	<input type="checkbox"/>	CRCL Firearms Evidence Room (A152)	CRCL	
2/4/20	8:30 am	<input type="checkbox"/>	CRCL Firearms Evidence Room (A152)	CRCL	<input checked="" type="checkbox"/>	MOBERG, JEFF	CRCL	safety check
2/4/20	9:02 am	<input checked="" type="checkbox"/>	MOBERG, JEFF	CRCL	<input type="checkbox"/>	CRCL Firearms Evidence Room (A152)	CRCL	
2/5/20	7:26 am	<input type="checkbox"/>	CRCL Firearms Evidence Room (A152)	CRCL	<input checked="" type="checkbox"/>	AFTOSMES, CARL	CRCL	
2/5/20	7:26 am	<input checked="" type="checkbox"/>	AFTOSMES, CARL	CRCL	<input type="checkbox"/>	HG BOXES 2	CRCL	
4/1/20	9:11 am	<input type="checkbox"/>	HG BOXES 2	CRCL	<input checked="" type="checkbox"/>	LICANO, PAUL	CRCL	
4/1/20	9:11 am	<input checked="" type="checkbox"/>	LICANO, PAUL	CRCL	<input type="checkbox"/>	CRCL Firearms Evidence Room (A152)	CRCL	
4/13/20	7:40 am	<input type="checkbox"/>	CRCL Firearms Evidence Room (A152)	CRCL	<input checked="" type="checkbox"/>	FORD, JARED	CRCL	

Item #: CRCL26 Continued on next page

DPS000325

**[X] indicates a PIN was entered  
\* indicates an update was performed**



**ARIZONA DEPARTMENT OF PUBLIC SAFETY  
CASE CHAIN OF CUSTODY REPORT  
Laboratory Case #: I20003903**

**Chain of Custody continued for Item#: CRCL26**

4/13/20	8:02 am	<input checked="" type="checkbox"/>	FORD, JARED	CRCL	<input type="checkbox"/>	CRCL Firearms Evidence Room (A152)	CRCL
4/13/20	1:28 pm	<input type="checkbox"/>	CRCL Firearms Evidence Room (A152)	CRCL	<input checked="" type="checkbox"/>	LICANO, PAUL	CRCL
4/13/20	1:28 pm	<input checked="" type="checkbox"/>	LICANO, PAUL	CRCL	<input type="checkbox"/>	HG BOXES 4	CRCL

**ITEM # : 9342**

**Outer Package #: CRCL26**

<u>Date</u>	<u>Time</u>	<u>PIN</u>	<u>From</u>		<u>PIN</u>	<u>To</u>	<u>Note</u>
1/22/20	8:04 am	<input type="checkbox"/>	P&E Intake	CRCL	<input checked="" type="checkbox"/>	RUIZ, MICHAEL	CRCL
1/22/20	8:04 am	<input checked="" type="checkbox"/>	RUIZ, MICHAEL	CRCL	<input type="checkbox"/>	SAFETY CHECK - CRCL	CRCL
2/4/20	8:23 am	<input type="checkbox"/>	SAFETY CHECK - CRCL	CRCL	<input checked="" type="checkbox"/>	TRIPOLI, JOSEPH	CRCL
2/4/20	8:23 am	<input checked="" type="checkbox"/>	TRIPOLI, JOSEPH	CRCL	<input type="checkbox"/>	CRCL Firearms Evidence Room (A152)	CRCL
2/4/20	8:30 am	<input type="checkbox"/>	CRCL Firearms Evidence Room (A152)	CRCL	<input checked="" type="checkbox"/>	MOBERG, JEFF	CRCL safety check
2/4/20	9:02 am	<input checked="" type="checkbox"/>	MOBERG, JEFF	CRCL	<input type="checkbox"/>	CRCL Firearms Evidence Room (A152)	CRCL
2/5/20	7:26 am	<input type="checkbox"/>	CRCL Firearms Evidence Room (A152)	CRCL	<input checked="" type="checkbox"/>	AFTOSMES, CARL	CRCL
2/5/20	7:26 am	<input checked="" type="checkbox"/>	AFTOSMES, CARL	CRCL	<input type="checkbox"/>	HG BOXES 2	CRCL
4/1/20	9:11 am	<input type="checkbox"/>	HG BOXES 2	CRCL	<input checked="" type="checkbox"/>	LICANO, PAUL	CRCL
4/1/20	9:11 am	<input checked="" type="checkbox"/>	LICANO, PAUL	CRCL	<input type="checkbox"/>	CRCL Firearms Evidence Room (A152)	CRCL
4/13/20	7:40 am	<input type="checkbox"/>	CRCL Firearms Evidence Room (A152)	CRCL	<input checked="" type="checkbox"/>	FORD, JARED	CRCL
4/13/20	8:02 am	<input checked="" type="checkbox"/>	FORD, JARED	CRCL	<input type="checkbox"/>	CRCL Firearms Evidence Room (A152)	CRCL
4/13/20	1:28 pm	<input type="checkbox"/>	CRCL Firearms Evidence Room (A152)	CRCL	<input checked="" type="checkbox"/>	LICANO, PAUL	CRCL
4/13/20	1:28 pm	<input checked="" type="checkbox"/>	LICANO, PAUL	CRCL	<input type="checkbox"/>	HG BOXES 4	CRCL

**ITEM # / DESCRIPTION: CRCL27**

**Box/ (9343) knife**

<u>Date</u>	<u>Time</u>	<u>PIN</u>	<u>From</u>		<u>PIN</u>	<u>To</u>	<u>Note</u>
1/22/20	8:04 am	<input type="checkbox"/>	P&E Intake	CRCL	<input checked="" type="checkbox"/>	RUIZ, MICHAEL	CRCL
1/22/20	8:04 am	<input checked="" type="checkbox"/>	RUIZ, MICHAEL	CRCL	<input type="checkbox"/>	LABORATORY STAGING SHELVES	CRCL
1/22/20	3:22 pm	<input type="checkbox"/>	LABORATORY STAGING SHELVES	CRCL	<input checked="" type="checkbox"/>	RUIZ, MICHAEL	CRCL
1/22/20	3:22 pm	<input checked="" type="checkbox"/>	RUIZ, MICHAEL	CRCL	<input type="checkbox"/>	SB17	CRCL
1/27/20	10:54 am	<input type="checkbox"/>	SB17	CRCL	<input checked="" type="checkbox"/>	MILES, RON	CRCL
1/27/20	10:54 am	<input checked="" type="checkbox"/>	MILES, RON	CRCL	<input checked="" type="checkbox"/>	VAN TASSEL, #7809, MISTY	Arizona Department of Public Safety



**ARIZONA DEPARTMENT OF PUBLIC SAFETY**  
**CASE CHAIN OF CUSTODY REPORT**  
 Laboratory Case #: I20003903

**Chain of Custody continued for Item#:CRCL27**

1/27/20	11:34 am	<input checked="" type="checkbox"/>	VAN TASSEL, #7809, MISTY	Arizona Department of Public Safety	<input checked="" type="checkbox"/>	RUIZ, MICHAEL	CRCL
1/27/20	11:34 am	<input checked="" type="checkbox"/>	RUIZ, MICHAEL	CRCL	<input type="checkbox"/>	SB17	CRCL
2/24/20	8:44 am	<input type="checkbox"/>	SB17	CRCL	<input checked="" type="checkbox"/>	KILLION, MATHEW	CRCL
2/24/20	8:44 am	<input checked="" type="checkbox"/>	KILLION, MATHEW	CRCL	<input type="checkbox"/>	SB15	CRCL

**ITEM # / DESCRIPTION: CRCL28**

**Box/ (9344) bed sheet**

<u>Date</u>	<u>Time</u>	<u>PIN</u>	<u>From</u>		<u>PIN</u>	<u>To</u>	<u>Note</u>
1/22/20	8:04 am	<input type="checkbox"/>	P&E Intake	CRCL	<input checked="" type="checkbox"/>	RUIZ, MICHAEL	CRCL
1/22/20	8:04 am	<input checked="" type="checkbox"/>	RUIZ, MICHAEL	CRCL	<input type="checkbox"/>	LABORATORY STAGING SHELVES	CRCL
1/22/20	2:46 pm	<input type="checkbox"/>	LABORATORY STAGING SHELVES	CRCL	<input checked="" type="checkbox"/>	RUIZ, MICHAEL	CRCL
1/22/20	2:46 pm	<input checked="" type="checkbox"/>	RUIZ, MICHAEL	CRCL	<input type="checkbox"/>	CY11	CRCL
1/29/20	8:34 am	<input type="checkbox"/>	CY11	CRCL	<input checked="" type="checkbox"/>	LICANO, PAUL	CRCL
1/29/20	8:34 am	<input checked="" type="checkbox"/>	LICANO, PAUL	CRCL	<input type="checkbox"/>	X9	CRCL
2/3/20	1:47 pm	<input type="checkbox"/>	X9	CRCL	<input checked="" type="checkbox"/>	KILLION, MATHEW	CRCL
2/3/20	1:47 pm	<input checked="" type="checkbox"/>	KILLION, MATHEW	CRCL	<input type="checkbox"/>	K1	CRCL
2/3/20	1:47 pm	<input checked="" type="checkbox"/>	KILLION, MATHEW	CRCL	<input type="checkbox"/>	K1	CRCL
2/3/20	1:47 pm	<input checked="" type="checkbox"/>	KILLION, MATHEW	CRCL	<input type="checkbox"/>	K1	CRCL
2/3/20	1:47 pm	<input checked="" type="checkbox"/>	KILLION, MATHEW	CRCL	<input type="checkbox"/>	K1	CRCL
2/3/20	1:47 pm	<input checked="" type="checkbox"/>	KILLION, MATHEW	CRCL	<input type="checkbox"/>	K1	CRCL
2/3/20	1:47 pm	<input checked="" type="checkbox"/>	KILLION, MATHEW	CRCL	<input type="checkbox"/>	K1	CRCL
2/3/20	1:47 pm	<input checked="" type="checkbox"/>	KILLION, MATHEW	CRCL	<input type="checkbox"/>	K1	CRCL

**ITEM # / DESCRIPTION: CRCL29**

**Box/ (9346) ax**

<u>Date</u>	<u>Time</u>	<u>PIN</u>	<u>From</u>		<u>PIN</u>	<u>To</u>	<u>Note</u>
1/22/20	8:04 am	<input type="checkbox"/>	P&E Intake	CRCL	<input checked="" type="checkbox"/>	RUIZ, MICHAEL	CRCL
1/22/20	8:04 am	<input checked="" type="checkbox"/>	RUIZ, MICHAEL	CRCL	<input type="checkbox"/>	LABORATORY STAGING SHELVES	CRCL
1/22/20	2:46 pm	<input type="checkbox"/>	LABORATORY STAGING SHELVES	CRCL	<input checked="" type="checkbox"/>	RUIZ, MICHAEL	CRCL
1/22/20	2:46 pm	<input checked="" type="checkbox"/>	RUIZ, MICHAEL	CRCL	<input type="checkbox"/>	CY11	CRCL
1/27/20	10:54 am	<input type="checkbox"/>	CY11	CRCL	<input checked="" type="checkbox"/>	MILES, RON	CRCL
1/27/20	10:54 am	<input checked="" type="checkbox"/>	MILES, RON	CRCL	<input checked="" type="checkbox"/>	VAN TASSEL, #7809, MISTY	Arizona Department of Public Safety
1/27/20	11:34 am	<input checked="" type="checkbox"/>	VAN TASSEL, #7809, MISTY	Arizona Department of Public Safety	<input checked="" type="checkbox"/>	RUIZ, MICHAEL	CRCL
1/27/20	11:34 am	<input checked="" type="checkbox"/>	RUIZ, MICHAEL	CRCL	<input type="checkbox"/>	CY11	CRCL

**ITEM # / DESCRIPTION: CRCL30**

**Box/ (9347) sword**

<u>Date</u>	<u>Time</u>	<u>PIN</u>	<u>From</u>		<u>PIN</u>	<u>To</u>	<u>Note</u>
1/22/20	8:04 am	<input type="checkbox"/>	P&E Intake	CRCL	<input checked="" type="checkbox"/>	RUIZ, MICHAEL	CRCL
1/22/20	8:04 am	<input checked="" type="checkbox"/>	RUIZ, MICHAEL	CRCL	<input type="checkbox"/>	LABORATORY STAGING SHELVES	CRCL

Item #: CRCL30 Continued on next page

[X] indicates a PIN was entered  
 \* indicates an update was performed



**ARIZONA DEPARTMENT OF PUBLIC SAFETY  
CASE CHAIN OF CUSTODY REPORT  
Laboratory Case #: I20003903**

**Chain of Custody continued for Item#:CRCL30**

1/22/20	3:22 pm	<input type="checkbox"/>	LABORATORY STAGING SHELVES	CRCL	<input checked="" type="checkbox"/>	RUIZ, MICHAEL	CRCL
1/22/20	3:22 pm	<input checked="" type="checkbox"/>	RUIZ, MICHAEL	CRCL	<input type="checkbox"/>	LG29	CRCL
1/27/20	10:54 am	<input type="checkbox"/>	LG29	CRCL	<input checked="" type="checkbox"/>	MILES, RON	CRCL
1/27/20	10:54 am	<input checked="" type="checkbox"/>	MILES, RON	CRCL	<input checked="" type="checkbox"/>	VAN TASSEL, #7809, MISTY	Arizona Department of Public Safety
1/27/20	11:34 am	<input checked="" type="checkbox"/>	VAN TASSEL, #7809, MISTY	Arizona Department of Public Safety	<input checked="" type="checkbox"/>	RUIZ, MICHAEL	CRCL
1/27/20	11:34 am	<input checked="" type="checkbox"/>	RUIZ, MICHAEL	CRCL	<input type="checkbox"/>	LG29	CRCL

**ITEM # / DESCRIPTION: CRCL31**

**Env/ (9324) sunglasses**

Date	Time	PIN	From		PIN	To	Note
1/22/20	8:43 am	<input type="checkbox"/>	P&E Intake	CRCL	<input checked="" type="checkbox"/>	RUIZ, MICHAEL	CRCL
1/22/20	8:43 am	<input checked="" type="checkbox"/>	RUIZ, MICHAEL	CRCL	<input type="checkbox"/>	803-2020	CRCL

**ITEM # / DESCRIPTION: CRCL32**

**Envelope (10084) Glove**

Date	Time	PIN	From		PIN	To	Note
1/30/20	8:22 am	<input type="checkbox"/>	P&E Intake	CRCL	<input checked="" type="checkbox"/>	MILES, RON	CRCL
1/30/20	8:22 am	<input checked="" type="checkbox"/>	MILES, RON	CRCL	<input type="checkbox"/>	803-2020	CRCL

**ITEM # / DESCRIPTION: CRCL33**

**Envelope (10086) Black Lighter and Sharpe**

Date	Time	PIN	From		PIN	To	Note
1/30/20	8:22 am	<input type="checkbox"/>	P&E Intake	CRCL	<input checked="" type="checkbox"/>	MILES, RON	CRCL
1/30/20	8:22 am	<input checked="" type="checkbox"/>	MILES, RON	CRCL	<input type="checkbox"/>	803-2020	CRCL

**ITEM # / DESCRIPTION: CRCL34**

**Envelope (10087) Bag**

Date	Time	PIN	From		PIN	To	Note
1/30/20	8:22 am	<input type="checkbox"/>	P&E Intake	CRCL	<input checked="" type="checkbox"/>	MILES, RON	CRCL
1/30/20	8:22 am	<input checked="" type="checkbox"/>	MILES, RON	CRCL	<input type="checkbox"/>	803-2020	CRCL

**ITEM # / DESCRIPTION: CRCL35**

**Envelope (10088) Credit Card, Metal Piece, Note**

Date	Time	PIN	From		PIN	To	Note
1/30/20	8:22 am	<input type="checkbox"/>	P&E Intake	CRCL	<input checked="" type="checkbox"/>	MILES, RON	CRCL
1/30/20	8:22 am	<input checked="" type="checkbox"/>	MILES, RON	CRCL	<input type="checkbox"/>	803-2020	CRCL

**ITEM # / DESCRIPTION: CRCL36**

**Envelope (10091) Cash - \$5.08**

Date	Time	PIN	From		PIN	To	Note
1/30/20	8:22 am	<input type="checkbox"/>	P&E Intake	CRCL	<input checked="" type="checkbox"/>	MILES, RON	CRCL
1/30/20	8:22 am	<input checked="" type="checkbox"/>	MILES, RON	CRCL	<input type="checkbox"/>	MONEY ROOM - SHELVES	CRCL

**ITEM # / DESCRIPTION: CRCL37**

**Envelope (10093) I.D. and Visa Card -Oregon DL, Military I.D., and River Mark Visa Card**

Item #: CRCL37 Continued on next page

DPS000328

[X] indicates a PIN was entered  
\* indicates an update was performed





ARIZONA DEPARTMENT OF PUBLIC SAFETY  
CASE CHAIN OF CUSTODY REPORT  
Laboratory Case #: I20003903

**Chain of Custody continued for Item#:CRCL37**

Date	Time	PIN	From		PIN	To		Note
1/30/20	1:30 pm	[ ]	P&E Intake	CRCL	[X]	MILES, RON	CRCL	
1/30/20	1:30 pm	[X]	MILES, RON	CRCL	[ ]	803-2020	CRCL	

**ITEM # / DESCRIPTION: CRCL38**

**Envelope (10094) Glove**

Date	Time	PIN	From		PIN	To		Note
1/30/20	8:22 am	[ ]	P&E Intake	CRCL	[X]	MILES, RON	CRCL	
1/30/20	8:22 am	[X]	MILES, RON	CRCL	[ ]	803-2020	CRCL	

**ITEM # / DESCRIPTION: CRCL39**

**Envelope (10095) Harmonica and pipe - pipe and harmonica from subjects front right pants pocket**

Date	Time	PIN	From		PIN	To		Note
1/30/20	1:30 pm	[ ]	P&E Intake	CRCL	[X]	MILES, RON	CRCL	
1/30/20	1:30 pm	[X]	MILES, RON	CRCL	[ ]	803-2020	CRCL	

**ITEM # / DESCRIPTION: CRCL40**

**Envelope (10096) Marijuana**

Date	Time	PIN	From		PIN	To		Note
1/30/20	8:22 am	[ ]	P&E Intake	CRCL	[X]	MILES, RON	CRCL	
1/30/20	8:22 am	[X]	MILES, RON	CRCL	[ ]	803-2020	CRCL	
3/3/20	9:13 am	[ ]	803-2020	CRCL	[X]	LICANO, PAUL	CRCL	
3/3/20	9:13 am	[X]	LICANO, PAUL	CRCL	[ ]	CSFT2_A	CRCL	
3/5/20	7:34 am	[ ]	CSFT2_A	CRCL	[X]	HAHN, CAITLIN	CRCL	
3/9/20	10:41 am	[X]	HAHN, CAITLIN	CRCL	[ ]	CS P&E Return	CRCL	
3/9/20	10:57 am	[ ]	CS P&E Return	CRCL	[X]	MILES, RON	CRCL	
3/9/20	10:57 am	[X]	MILES, RON	CRCL	[ ]	803-2020	CRCL	

**ITEM # : 10096**

**Outer Package #: CRCL40**

Date	Time	PIN	From		PIN	To		Note
1/30/20	8:22 am	[ ]	P&E Intake	CRCL	[X]	MILES, RON	CRCL	
1/30/20	8:22 am	[X]	MILES, RON	CRCL	[ ]	803-2020	CRCL	
3/3/20	9:13 am	[ ]	803-2020	CRCL	[X]	LICANO, PAUL	CRCL	
3/3/20	9:13 am	[X]	LICANO, PAUL	CRCL	[ ]	CSFT2_A	CRCL	
3/5/20	7:34 am	[ ]	CSFT2_A	CRCL	[X]	HAHN, CAITLIN	CRCL	
3/9/20	10:41 am	[X]	HAHN, CAITLIN	CRCL	[ ]	CS P&E Return	CRCL	
3/9/20	10:57 am	[ ]	CS P&E Return	CRCL	[X]	MILES, RON	CRCL	
3/9/20	10:57 am	[X]	MILES, RON	CRCL	[ ]	803-2020	CRCL	

**ITEM # / DESCRIPTION: CRCL41**

**Box (10097) Clothing**

Date	Time	PIN	From		PIN	To		Note
1/30/20	8:22 am	[ ]	P&E Intake	CRCL	[X]	MILES, RON	CRCL	
1/30/20	8:22 am	[X]	MILES, RON	CRCL	[ ]	CY18	CRCL	

[X] indicates a PIN was entered  
\* indicates an update was performed



ARIZONA DEPARTMENT OF PUBLIC SAFETY  
CASE CHAIN OF CUSTODY REPORT  
Laboratory Case #: I20003903

**Chain of Custody continued for Item#:CRCL42**

**ITEM # / DESCRIPTION: CRCL42**

**Box (10098) Clothing**

<u>Date</u>	<u>Time</u>	<u>PIN</u>	<u>From</u>		<u>PIN</u>	<u>To</u>		<u>Note</u>
1/30/20	8:22 am	[ ]	P&E Intake	CRCL	[X]	MILES, RON	CRCL	
1/30/20	8:22 am	[X]	MILES, RON	CRCL	[ ]	CY18	CRCL	

**ITEM # / DESCRIPTION: CRCL43**

**Box (10099) Clothing**

<u>Date</u>	<u>Time</u>	<u>PIN</u>	<u>From</u>		<u>PIN</u>	<u>To</u>		<u>Note</u>
1/30/20	8:22 am	[ ]	P&E Intake	CRCL	[X]	MILES, RON	CRCL	
1/30/20	8:22 am	[X]	MILES, RON	CRCL	[ ]	CY18	CRCL	

**ITEM # / DESCRIPTION: CRCL44**

**Envelope (10100) Handcuffs**

<u>Date</u>	<u>Time</u>	<u>PIN</u>	<u>From</u>		<u>PIN</u>	<u>To</u>		<u>Note</u>
1/30/20	8:22 am	[ ]	P&E Intake	CRCL	[X]	MILES, RON	CRCL	
1/30/20	8:22 am	[X]	MILES, RON	CRCL	[ ]	803-2020	CRCL	

**ITEM # / DESCRIPTION: CRCL45**

**Box (10101) Clothing**

<u>Date</u>	<u>Time</u>	<u>PIN</u>	<u>From</u>		<u>PIN</u>	<u>To</u>		<u>Note</u>
1/30/20	8:22 am	[ ]	P&E Intake	CRCL	[X]	MILES, RON	CRCL	
1/30/20	8:22 am	[X]	MILES, RON	CRCL	[ ]	CY18	CRCL	

**ITEM # / DESCRIPTION: CRCL46**

**Box (10102) Clothing**

<u>Date</u>	<u>Time</u>	<u>PIN</u>	<u>From</u>		<u>PIN</u>	<u>To</u>		<u>Note</u>
1/30/20	8:22 am	[ ]	P&E Intake	CRCL	[X]	MILES, RON	CRCL	
1/30/20	8:22 am	[X]	MILES, RON	CRCL	[ ]	CY18	CRCL	

**ITEM # / DESCRIPTION: CRCL47**

**Box (10103) Harness**

<u>Date</u>	<u>Time</u>	<u>PIN</u>	<u>From</u>		<u>PIN</u>	<u>To</u>		<u>Note</u>
1/30/20	8:22 am	[ ]	P&E Intake	CRCL	[X]	MILES, RON	CRCL	
1/30/20	8:22 am	[X]	MILES, RON	CRCL	[ ]	CY18	CRCL	

**ITEM # / DESCRIPTION: CRCL48**

**Envelope (10104) Clothing**

<u>Date</u>	<u>Time</u>	<u>PIN</u>	<u>From</u>		<u>PIN</u>	<u>To</u>		<u>Note</u>
1/30/20	8:22 am	[ ]	P&E Intake	CRCL	[X]	MILES, RON	CRCL	
1/30/20	8:22 am	[X]	MILES, RON	CRCL	[ ]	803-2020	CRCL	

**ITEM # / DESCRIPTION: CRCL49**

**Envelope (10105) Clothing**

<u>Date</u>	<u>Time</u>	<u>PIN</u>	<u>From</u>		<u>PIN</u>	<u>To</u>		<u>Note</u>
1/30/20	8:22 am	[ ]	P&E Intake	CRCL	[X]	MILES, RON	CRCL	

Item #: CRCL49 Continued on next page

[X] indicates a PIN was entered  
\* indicates an update was performed



ARIZONA DEPARTMENT OF PUBLIC SAFETY  
CASE CHAIN OF CUSTODY REPORT  
Laboratory Case #: I20003903

**Chain of Custody continued for Item#:CRCL49**

1/30/20 8:22 am [X] MILES, RON CRCL [ ] 803-2020 CRCL

**ITEM # / DESCRIPTION: CRCL50**

**Envelope (10106) Bag**

<u>Date</u>	<u>Time</u>	<u>PIN</u>	<u>From</u>		<u>PIN</u>	<u>To</u>	<u>Note</u>
1/30/20	8:22 am	[ ]	P&E Intake	CRCL	[X]	MILES, RON	CRCL
1/30/20	8:22 am	[X]	MILES, RON	CRCL	[ ]	803-2020	CRCL

**ITEM # / DESCRIPTION: CRCL51**

**Envelope (10107) Clothing**

<u>Date</u>	<u>Time</u>	<u>PIN</u>	<u>From</u>		<u>PIN</u>	<u>To</u>	<u>Note</u>
1/30/20	8:22 am	[ ]	P&E Intake	CRCL	[X]	MILES, RON	CRCL
1/30/20	8:22 am	[X]	MILES, RON	CRCL	[ ]	803-2020	CRCL

**ITEM # / DESCRIPTION: CRCL52**

**Envelope (10109) Rope, clips, pouch - rope, clips, and pouch from subject**

<u>Date</u>	<u>Time</u>	<u>PIN</u>	<u>From</u>		<u>PIN</u>	<u>To</u>	<u>Note</u>
1/30/20	1:30 pm	[ ]	P&E Intake	CRCL	[X]	MILES, RON	CRCL
1/30/20	1:30 pm	[X]	MILES, RON	CRCL	[ ]	803-2020	CRCL

**ITEM # / DESCRIPTION: CRCL53**

**Envelope (10110) Key**

<u>Date</u>	<u>Time</u>	<u>PIN</u>	<u>From</u>		<u>PIN</u>	<u>To</u>	<u>Note</u>
1/30/20	8:22 am	[ ]	P&E Intake	CRCL	[X]	MILES, RON	CRCL
1/30/20	8:22 am	[X]	MILES, RON	CRCL	[ ]	803-2020	CRCL

**ITEM # / DESCRIPTION: CRCL54**

**Envelope (10111) Case**

<u>Date</u>	<u>Time</u>	<u>PIN</u>	<u>From</u>		<u>PIN</u>	<u>To</u>	<u>Note</u>
1/30/20	8:22 am	[ ]	P&E Intake	CRCL	[X]	MILES, RON	CRCL
1/30/20	8:22 am	[X]	MILES, RON	CRCL	[ ]	803-2020	CRCL

**ITEM # / DESCRIPTION: CRCL55**

**Envelope (10112) Clothing**

<u>Date</u>	<u>Time</u>	<u>PIN</u>	<u>From</u>		<u>PIN</u>	<u>To</u>	<u>Note</u>
1/30/20	8:22 am	[ ]	P&E Intake	CRCL	[X]	MILES, RON	CRCL
1/30/20	8:22 am	[X]	MILES, RON	CRCL	[ ]	803-2020	CRCL

**ITEM # / DESCRIPTION: CRCL56**

**Envelope (10113) Bracelet**

<u>Date</u>	<u>Time</u>	<u>PIN</u>	<u>From</u>		<u>PIN</u>	<u>To</u>	<u>Note</u>
1/30/20	8:22 am	[ ]	P&E Intake	CRCL	[X]	MILES, RON	CRCL
1/30/20	8:22 am	[X]	MILES, RON	CRCL	[ ]	803-2020	CRCL

**ITEM # / DESCRIPTION: CRCL57**

**Envelope (10114) Bracelet**

<u>Date</u>	<u>Time</u>	<u>PIN</u>	<u>From</u>		<u>PIN</u>	<u>To</u>	<u>Note</u>
-------------	-------------	------------	-------------	--	------------	-----------	-------------

Item #: CRCL57 Continued on next page

[X] indicates a PIN was entered  
\* indicates an update was performed



ARIZONA DEPARTMENT OF PUBLIC SAFETY  
CASE CHAIN OF CUSTODY REPORT  
Laboratory Case #: I20003903

**Chain of Custody continued for Item#:CRCL57**

1/30/20	8:22 am	<input type="checkbox"/>	P&E Intake	CRCL	<input checked="" type="checkbox"/>	MILES, RON	CRCL
1/30/20	8:22 am	<input checked="" type="checkbox"/>	MILES, RON	CRCL	<input type="checkbox"/>	803-2020	CRCL

**ITEM # / DESCRIPTION: CRCL58**

**Envelope (10115) Pipe and lighter - pipe and yellow light from subject collected by M.E. during autopsy,**

<u>Date</u>	<u>Time</u>	<u>PIN</u>	<u>From</u>		<u>PIN</u>	<u>To</u>	<u>Note</u>
1/30/20	1:30 pm	<input type="checkbox"/>	P&E Intake	CRCL	<input checked="" type="checkbox"/>	MILES, RON	CRCL
1/30/20	1:30 pm	<input checked="" type="checkbox"/>	MILES, RON	CRCL	<input type="checkbox"/>	803-2020	CRCL

**ITEM # / DESCRIPTION: CRCL59**

**Envelope (10116) Key**

<u>Date</u>	<u>Time</u>	<u>PIN</u>	<u>From</u>		<u>PIN</u>	<u>To</u>	<u>Note</u>
1/30/20	8:22 am	<input type="checkbox"/>	P&E Intake	CRCL	<input checked="" type="checkbox"/>	MILES, RON	CRCL
1/30/20	8:22 am	<input checked="" type="checkbox"/>	MILES, RON	CRCL	<input type="checkbox"/>	803-2020	CRCL

**ITEM # / DESCRIPTION: CRCL60**

**Envelope (10117) Nail**

<u>Date</u>	<u>Time</u>	<u>PIN</u>	<u>From</u>		<u>PIN</u>	<u>To</u>	<u>Note</u>
1/30/20	8:22 am	<input type="checkbox"/>	P&E Intake	CRCL	<input checked="" type="checkbox"/>	MILES, RON	CRCL
1/30/20	8:22 am	<input checked="" type="checkbox"/>	MILES, RON	CRCL	<input type="checkbox"/>	803-2020	CRCL

**ITEM # / DESCRIPTION: CRCL61**

**Envelope (10118) Bullet**

<u>Date</u>	<u>Time</u>	<u>PIN</u>	<u>From</u>		<u>PIN</u>	<u>To</u>	<u>Note</u>
1/30/20	8:22 am	<input type="checkbox"/>	P&E Intake	CRCL	<input checked="" type="checkbox"/>	MILES, RON	CRCL
1/30/20	8:22 am	<input checked="" type="checkbox"/>	MILES, RON	CRCL	<input type="checkbox"/>	803-2020	CRCL

**ITEM # / DESCRIPTION: CRCL62**

**Envelope (10119) Fingerprint**

<u>Date</u>	<u>Time</u>	<u>PIN</u>	<u>From</u>		<u>PIN</u>	<u>To</u>	<u>Note</u>
1/30/20	8:22 am	<input type="checkbox"/>	P&E Intake	CRCL	<input checked="" type="checkbox"/>	MILES, RON	CRCL
1/30/20	8:22 am	<input checked="" type="checkbox"/>	MILES, RON	CRCL	<input type="checkbox"/>	803-2020	CRCL

**ITEM # / DESCRIPTION: CRCL63**

**Envelope (10120) Bullet**

<u>Date</u>	<u>Time</u>	<u>PIN</u>	<u>From</u>		<u>PIN</u>	<u>To</u>	<u>Note</u>
1/30/20	8:22 am	<input type="checkbox"/>	P&E Intake	CRCL	<input checked="" type="checkbox"/>	MILES, RON	CRCL
1/30/20	8:22 am	<input checked="" type="checkbox"/>	MILES, RON	CRCL	<input type="checkbox"/>	803-2020	CRCL

**ITEM # / DESCRIPTION: CRCL64**

**Envelope (10122) Bullet**

<u>Date</u>	<u>Time</u>	<u>PIN</u>	<u>From</u>		<u>PIN</u>	<u>To</u>	<u>Note</u>
1/30/20	8:22 am	<input type="checkbox"/>	P&E Intake	CRCL	<input checked="" type="checkbox"/>	MILES, RON	CRCL
1/30/20	8:22 am	<input checked="" type="checkbox"/>	MILES, RON	CRCL	<input type="checkbox"/>	803-2020	CRCL

**ITEM # / DESCRIPTION: CRCL65**

**Envelope (10123) Bullet**

Item #: CRCL65 Continued on next page

[X] indicates a PIN was entered  
\* indicates an update was performed



ARIZONA DEPARTMENT OF PUBLIC SAFETY  
CASE CHAIN OF CUSTODY REPORT  
Laboratory Case #: I20003903

**Chain of Custody continued for Item#:CRCL65**

<u>Date</u>	<u>Time</u>	<u>PIN</u>	<u>From</u>		<u>PIN</u>	<u>To</u>		<u>Note</u>
1/30/20	8:22 am	[ ]	P&E Intake	CRCL	[X]	MILES, RON	CRCL	
1/30/20	8:22 am	[X]	MILES, RON	CRCL	[ ]	803-2020	CRCL	

**ITEM # / DESCRIPTION: CRCL66**

**Envelope (10124) Compact Disc**

<u>Date</u>	<u>Time</u>	<u>PIN</u>	<u>From</u>		<u>PIN</u>	<u>To</u>		<u>Note</u>
1/30/20	8:22 am	[ ]	P&E Intake	CRCL	[X]	MILES, RON	CRCL	
1/30/20	8:22 am	[X]	MILES, RON	CRCL	[ ]	803-2020	CRCL	

**ITEM # / DESCRIPTION: CRCL67**

**Env/ (10191) DISK DRIVE**

<u>Date</u>	<u>Time</u>	<u>PIN</u>	<u>From</u>		<u>PIN</u>	<u>To</u>		<u>Note</u>
1/30/20	8:30 am	[ ]	P&E Intake	CRCL	[X]	ARNONE, CHARLES	CRCL	
1/30/20	8:30 am	[X]	ARNONE, CHARLES	CRCL	[ ]	803-2020	CRCL	

**ITEM # / DESCRIPTION: CRCL68**

**Env/ (10121) BLOOD BLOT**

<u>Date</u>	<u>Time</u>	<u>PIN</u>	<u>From</u>		<u>PIN</u>	<u>To</u>		<u>Note</u>
1/30/20	10:24 am	[ ]	P&E Intake	CRCL	[X]	MILES, RON	CRCL	
1/30/20	10:24 am	[X]	MILES, RON	CRCL	[ ]	803-2020	CRCL	

**ITEM # / DESCRIPTION: CRCL69**

**Env/ (12917) COMPACT DISC**

<u>Date</u>	<u>Time</u>	<u>PIN</u>	<u>From</u>		<u>PIN</u>	<u>To</u>		<u>Note</u>
2/18/20	3:45 pm	[ ]	P&E Intake	CRCL	[X]	MILES, RON	CRCL	
2/18/20	3:45 pm	[X]	MILES, RON	CRCL	[ ]	803-2020	CRCL	

**ITEM # / DESCRIPTION: CRCL70**

**Env/ (12918) COMPACT DISC**

<u>Date</u>	<u>Time</u>	<u>PIN</u>	<u>From</u>		<u>PIN</u>	<u>To</u>		<u>Note</u>
2/18/20	3:45 pm	[ ]	P&E Intake	CRCL	[X]	MILES, RON	CRCL	
2/18/20	3:45 pm	[X]	MILES, RON	CRCL	[ ]	803-2020	CRCL	

**ITEM # / DESCRIPTION: CRCL71**

**ENVELOPE (21620) Compact Disc**

<u>Date</u>	<u>Time</u>	<u>PIN</u>	<u>From</u>		<u>PIN</u>	<u>To</u>		<u>Note</u>
5/8/20	11:43 am	[ ]	P&E Intake	CRCL	[X]	LICANO, PAUL	CRCL	
5/8/20	11:43 am	[X]	LICANO, PAUL	CRCL	[ ]	803-2020	CRCL	

**ITEM # / DESCRIPTION: CRCL72**

**ENVELOPE (21622) Compact Disc**

<u>Date</u>	<u>Time</u>	<u>PIN</u>	<u>From</u>		<u>PIN</u>	<u>To</u>		<u>Note</u>
5/8/20	11:43 am	[ ]	P&E Intake	CRCL	[X]	LICANO, PAUL	CRCL	
5/8/20	11:43 am	[X]	LICANO, PAUL	CRCL	[ ]	803-2020	CRCL	

[X] indicates a PIN was entered  
\* indicates an update was performed



ARIZONA DEPARTMENT OF PUBLIC SAFETY  
CASE CHAIN OF CUSTODY REPORT  
Laboratory Case #: I20003903

**Chain of Custody continued for Item#:CRCL73**

**ITEM # / DESCRIPTION: CRCL73**

**ENVELOPE (21623) Compact Disc**

Date	Time	PIN	From		PIN	To	Note
5/8/20	11:43 am	[ ]	P&E Intake	CRCL	[X]	LICANO, PAUL	CRCL
5/8/20	11:43 am	[X]	LICANO, PAUL	CRCL	[ ]	803-2020	CRCL

**ITEM # / DESCRIPTION: CRCL74**

**ENVELOPE (21625) Compact Disc**

Date	Time	PIN	From		PIN	To	Note
5/8/20	11:43 am	[ ]	P&E Intake	CRCL	[X]	LICANO, PAUL	CRCL
5/8/20	11:43 am	[X]	LICANO, PAUL	CRCL	[ ]	803-2020	CRCL

**ITEM # / DESCRIPTION: CRCL75**

**ENVELOPE (21626) Compact Disc**

Date	Time	PIN	From		PIN	To	Note
5/8/20	11:43 am	[ ]	P&E Intake	CRCL	[X]	LICANO, PAUL	CRCL
5/8/20	11:43 am	[X]	LICANO, PAUL	CRCL	[ ]	803-2020	CRCL

**ITEM # / DESCRIPTION: CRCL76**

**ENVELOPE (21627) Miscellaneous**

Date	Time	PIN	From		PIN	To	Note
5/8/20	11:43 am	[ ]	P&E Intake	CRCL	[X]	LICANO, PAUL	CRCL
5/8/20	11:43 am	[X]	LICANO, PAUL	CRCL	[ ]	803-2020	CRCL

**ITEM # / DESCRIPTION: CRCL77**

**ENVELOPE (21628) Compact Disc**

Date	Time	PIN	From		PIN	To	Note
5/8/20	11:43 am	[ ]	P&E Intake	CRCL	[X]	LICANO, PAUL	CRCL
5/8/20	11:43 am	[X]	LICANO, PAUL	CRCL	[ ]	803-2020	CRCL

**ITEM # / DESCRIPTION: CRCL78**

**ENVELOPE (21630) Compact Disc**

Date	Time	PIN	From		PIN	To	Note
5/8/20	11:43 am	[ ]	P&E Intake	CRCL	[X]	LICANO, PAUL	CRCL
5/8/20	11:43 am	[X]	LICANO, PAUL	CRCL	[ ]	803-2020	CRCL

**ITEM # / DESCRIPTION: CRCL79**

**ENVELOPE (21631) Compact Disc**

Date	Time	PIN	From		PIN	To	Note
5/8/20	11:43 am	[ ]	P&E Intake	CRCL	[X]	LICANO, PAUL	CRCL
5/8/20	11:43 am	[X]	LICANO, PAUL	CRCL	[ ]	803-2020	CRCL

**ITEM # / DESCRIPTION: CRCL80**

**ENVELOPE (21633) Compact Disc**

Date	Time	PIN	From		PIN	To	Note
5/8/20	11:43 am	[ ]	P&E Intake	CRCL	[X]	LICANO, PAUL	CRCL

Item #: CRCL80 Continued on next page

[X] indicates a PIN was entered  
\* indicates an update was performed



ARIZONA DEPARTMENT OF PUBLIC SAFETY  
CASE CHAIN OF CUSTODY REPORT  
Laboratory Case #: I20003903

**Chain of Custody continued for Item#:CRCL80**

5/8/20 11:43 am     LICANO, PAUL    CRCL     803-2020    CRCL

**ITEM # / DESCRIPTION: CRCL81**

**ENVELOPE (21634) Compact Disc**

<u>Date</u>	<u>Time</u>	<u>PIN</u>	<u>From</u>		<u>PIN</u>	<u>To</u>		<u>Note</u>
5/8/20	11:43 am	<input type="checkbox"/>	P&E Intake	CRCL	<input checked="" type="checkbox"/>	LICANO, PAUL	CRCL	
5/8/20	11:43 am	<input checked="" type="checkbox"/>	LICANO, PAUL	CRCL	<input type="checkbox"/>	803-2020	CRCL	

**ITEM # / DESCRIPTION: CRCL82**

**ENVELOPE (21635) Compact Disc**

<u>Date</u>	<u>Time</u>	<u>PIN</u>	<u>From</u>		<u>PIN</u>	<u>To</u>		<u>Note</u>
5/8/20	11:43 am	<input type="checkbox"/>	P&E Intake	CRCL	<input checked="" type="checkbox"/>	LICANO, PAUL	CRCL	
5/8/20	11:43 am	<input checked="" type="checkbox"/>	LICANO, PAUL	CRCL	<input type="checkbox"/>	803-2020	CRCL	

**[X] indicates a PIN was entered  
\* indicates an update was performed**

**COCONINO COUNTY HEALTH DEPARTMENT  
OFFICE OF THE MEDICAL EXAMINER  
RECEIPT FOR MEDICOLEGAL MATERIAL**  
Received at: 4402 E. Huntington Drive, Flagstaff, AZ 86004

M. E. CASE # 20-047  
DECEDENT: Messare, Jonathan  
AGENCY OF INV.: Sedona PD/AZDPS

COLLECTION DATE: 01/23/2020  
COLLECTION START TIME: 0930 hrs.

ITEM(S)	CONTAINER	SEAL	EVIDENCE ID #
GRAY MIT FROM LEFT SIDE PANTS POCKET	BROWN PAPER EVIDENCE BAG	TAPE	1 <b>AR15</b>
BLACK LIGHTER AND BLACK SHARPIE FROM LEFT FRONT PANTS POCKET	BROWN PAPER EVIDENCE BAG	TAPE	2 <b>AR16</b>
2 MISC. CARDS, OR DRIVER LICENSE, VA ID, VISA CARD, MISC. PAPER, 3 PENNIED, 1 NICKEL, 1 FIVE DOLLAR BILL, 1 MISC. METAL PIECE FROM BLACK POUCH	BROWN PAPER EVIDENCE BAG <b>AR17</b>	TAPE	3 <b>AR17.1 AR17.2 AR17.3</b>
BLACK POUCH WITH PIPE AND GREEN SUBSTANCE	BROWN PAPER EVIDENCE BAG	TAPE	4 <b>AR18</b>
PIPE AND HARMONICA FROM RIGHT FRONT PANTS POCKET	BROWN PAPER EVIDENCE BAG	TAPE	5 <b>AR19</b>
MIT FROM RIGHT SIDE PANTS POCKET	BROWN PAPER EVIDENCE BAG	TAPE	6 <b>AR20</b>
LEFT SHOE AND SOCK	BROWN PAPER EVIDENCE BAG	TAPE	7 <b>AR21</b>
RIGHT SHOE AND SOCK	BROWN PAPER EVIDENCE BAG	TAPE	8 <b>AR22</b>
GREEN PANTS AND BROWN BELT	BROWN PAPER EVIDENCE BAG	TAPE	9 <b>AR23</b>
HANDCUFF	BROWN PAPER EVIDENCE BAG	TAPE	10 <b>AR24</b>
CAMO VEST	BROWN PAPER EVIDENCE BAG	TAPE	11 <b>AR25</b>
GREEN VEST	BROWN PAPER EVIDENCE BAG	TAPE	12 <b>AR26</b>
HARNESS	BROWN PAPER EVIDENCE BAG	TAPE	13 <b>AR27</b>
BLACK SCARF	BROWN PAPER EVIDENCE BAG	TAPE	14 <b>AR28</b>
HAT	BROWN PAPER EVIDENCE BAG	TAPE	15 <b>AR29</b>
2 GLOVES, CAMO MASK, BLACK POUCH, HANDCUFF KEY, 2 CLIPS	BROWN PAPER EVIDENCE BAG <b>AR30</b>	TAPE	16 <b>AR30.1 AR30.2</b>
BLACK KNIFE SHEATH AND ROPE	BROWN PAPER EVIDENCE BAG	TAPE	17 <b>AR31</b>
2 BLACK BELT STRAPS	BROWN PAPER EVIDENCE BAG	TAPE	18 <b>AR32</b>
RIGHT BROWN BRACELET	BROWN PAPER EVIDENCE BAG	TAPE	19 <b>AR33</b>

Coconino County Medical Examiner  
 MOD: 1/20/2020 Case#: 20-047  
 Name: Messare, Jonathan  
 Sex: M Race: W DOB: [REDACTED]  
 Invest. Agency: AZDPS  
 INV: KB



**COCONINO COUNTY HEALTH DEPARTMENT  
OFFICE OF THE MEDICAL EXAMINER  
RECEIPT FOR MEDICOLEGAL MATERIAL**  
Received at: 4402 E. Huntington Drive, Flagstaff, AZ 86004

M. E. CASE # 20-047  
DECEDENT: Messare, Jonathan  
AGENCY OF INV.: Sedona PD/AZDPS

COLLECTION DATE: 01/23/2020  
COLLECTION START TIME: 0930 hrs.

ITEM(S)	CONTAINER	SEAL	EVIDENCE ID #
LEFT BROWN BRACELET	BROWN PAPER EVIDENCE BAG	TAPE	20
PIPE AND LIGHTER FROM RIGHT BOTTOM POCKET OF CAMO VEST	BROWN PAPER EVIDENCE BAG	TAPE	21
MISC. METAL PIECE FROM TOP RIGHT POCKET OF CAMO VEST	BROWN PAPER EVIDENCE BAG	TAPE	22
RIGHT FINGERNAIL CLIPPINGS @ 1040	BOX	TAPE	23
LEFT FINGERNAIL CLIPPINGS AND CLIPPERS @ 1043	BOX	TAPE	24
PROJECTILE FROM SUBCUTANEOUS ASPECT OF LEFT BACK @ 1015	BOX	TAPE	25
FINGERPRINT CARD	SLEEVE	N/A	26
PROJECTILE FROM RIGHT ABDOMINAL WALL @ 1407	BOX	TAPE	27
BLOOD BLOT @ 1417	ENVELOPE	TAPE	28
PROJECTILE FROM SUBCUTANEOUS ASPECT OF RIGHT BACK @ 1503	BOX	TAPE	29
PROJECTILE FROM HEART @ 1516	BOX	TAPE	30
PHOTO CD	SLEEVE	N/A	31

AR34  
AR35  
AR36  
AR37  
AR38  
AR39  
AR40  
AR41  
AR42  
AR43  
AR44

**CHAIN OF CUSTODY**

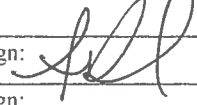
DATE	RELINQUISHED BY	RECEIVED BY
1/23/2020	Print: Elizabeth Ross Sign: 	Print: ANDREW REED Sign: 
	Print:                      Sign:	Print:                      Sign:

Coconino County Medical Examiner  
DOD: 01/20/2020 Case#20-047  
Name: Messare, Jonathan David  
Sex: M Race: W DOB: XXXXXXXXXX  
Invest. Agency: Sedona PD/DPS  
INV: KB

# CHAIN OF CUSTODY

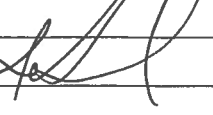
DATE	RELINQUISHED BY		RECEIVED BY	
1/23/2020	Print: Elizabeth Ross	Sign: 	Print: Andrew Reed	Sign: 
	Print:	Sign:	Print:	Sign:



**ARIZONA DEPARTMENT OF PUBLIC SAFETY  
NON-COLLECTED EVIDENCE RECOVERY LOG**

**DR NUMBER: I20003903**

ITEM	DESCRIPTION	LOCATION FOUND	TIME
AR.A	Black Glock 17 9mm semiautomatic handgun with mounted light (Gun S/N: BEAG455) (TLR1 Light S/N: 1995581115)	Sedona Police Department	01/20/2020 1834
AR.B	Black Glock magazine (17 round capacity) containing 16 rounds of ammunition plus one in the chamber (Federal Luger 9mm)	Sedona Police Department	01/20/2020 1838
AR.C	Black Glock magazine (17 round capacity) containing 16 rounds of ammunition (Federal Luger 9mm)	Sedona Police Department	01/20/2020 1839
AR.D	Black Glock magazine (17 round capacity) containing 16 rounds of ammunition (Federal Luger 9mm)	Sedona Police Department	01/20/2020 1842

Detective Name	ID No.	Location	Date	Supervisor
Andrew Reed	7325	31030100	01/22/2020	Sergeant Matthew Monaco, #6645



**ARIZONA DEPARTMENT OF PUBLIC SAFETY  
NON-COLLECTED EVIDENCE RECOVERY LOG**

| **DR NUMBER:** | **120003903** |

ITEM	DESCRIPTION	LOCATION FOUND	TIME
MVA	Ford Explorer Vehicle #15 (Sedona PD) License Plate G635GT	Facing East in the inner perimeter	2156
MVB	Ford Explorer Vehicle #7 (Sedona PD) License Plate G661HV	Facing southeast in the inner perimeter	2156
MVC	Ford Explorer Vehicle #14 (Sedona PD) License Plate G634GT	Facing northeast in the inner perimeter	2156
MVD	Group of blood drops	West of suspect's feet	2156
MVE	Group of blood drops	West of suspect's feet	2156
MVF	Pool of blood	South of suspect	2156
MVG	Box of gloves	North of evidence item 8	2156
MVBH	Back up weapon Glock 43 9mm	Under front driver's seat of vehicle #7	2156
MVBH.1	Magazine with 6 FC 9mm Lugars and 1 in chamber	Magazine from MVBH	2156
MVBH.2	Second Magazine-6 rounds FC 9mm Lugars	Magazine found in back up bag	2156
MVBH.3	Third Magazine-6 rounds FC 9mm Lugars	Magazine found in back up bag	2156

Detective Name	ID No.	Location	Date	Supervisor
M Van Tassel	7809	31030100	01/20/2020	Sergeant M. Monaco





**ARIZONA DEPARTMENT OF PUBLIC SAFETY**  
**NON-COLLECTED EVIDENCE RECOVERY LOG**



**ARIZONA DEPARTMENT OF PUBLIC SAFETY**  
**NON-COLLECTED EVIDENCE RECOVERY LOG**

**Re: 11-22-19 Briefing AM\*\*\*\*\*OFFICER SAFETY\*\*\*\*\***

Jonathan Reed <JReed@sedonaaz.gov>

Fri 11/22/2019 9:05 PM

To: Laura Leon <LLeon@sedonaaz.gov>; PD Briefing <PDBriefing@sedonaaz.gov>; PD Communications <PDCommunications@sedonaaz.gov>

Everyone,

Seeing the briefing I decided to do some research because the briefing did not give much information on the behavioral health call, and I wanted to know if the mental health concerns and fb posts of weapons were something I needed to be aware of. (Something just didn't sit right with me) Upon further research we have had two calls now regarding Jonathan David Messare DOB [REDACTED] who is new to Sedona from Portland, Oregon. The first contact was reference DR 190012751 where a business owner on Contractors Road was concerned about Messare and thought he might have warrants out of Oregon. At that time Portland PD advised of Officer safety risks out of Oregon and Messare was known to resist arrest as well as carry knives. The second incident was the behavioral health call from briefing on 11/22/2019.

Upon further research Messare had multiple very serious encounters and felony arrests out of Portland, Oregon as recent as March of this year. One incident involved Messare laying naked in a school baseball field armed with a hatchet, dog leash with a carabiner on the end, a knife, and other weapons. Messare stabbed an Officer while resisting arrest and charging at Officers in this incident. A search warrant served at his house yielded an AR-15, shotgun, pistols, tactical gear, body armor and ammunition which he was prohibited from possessing.

After being released from Jail Messare was involved in another incident outside a storage unit where he was wearing a ballistic helmet, making statements of murdering his wife and daughter, and again armed with a hatchet. After a lengthy standoff he was taken into custody. During both arrests he was armed, displayed fear and aggression towards law enforcement, and assaulted Officers as well as jail staff.

Moral of the story, if we have any contact with this subject use caution, and remember the less lethal tools and tactics we have at our disposal to get him into custody safely (i.e. less lethal shotgun, 40mm, K9, taser) if needed. It is apparent he is potentially Seriously Mentally Ill (SMI) and suffers from delusions and violent tendencies. Also anticipate him being armed, and being that Arizona allows the private sale of firearms he likely has access to guns despite being a prohibited possessor.

Be safe,

Jon Reed #732  
Sedona Police Department  
K9, SWAT, FTO  
928-282-3100





ARIZONA DEPARTMENT OF PUBLIC SAFETY  
SCIENTIFIC EXAMINATION REPORT

DR NO. I20003903

Page 1 of 1

AGENCY Arizona Department of Public Safety



AGENCY NO. I20003903

OFFICER REED, #7325

DATE April 13, 2020

NAME(S) MESSARE, JONATHAN DAVID

**EXAMINATION REQUESTED**

Firearm Exam

**ITEMS**

- 9341. Glock model 17, 9mm Luger caliber semiautomatic pistol, serial number BEAG443 with TLR-1 weapon light
- 9342. Glock model 17, 9mm Luger caliber semiautomatic pistol, serial number BEAG461

**RESULTS / INTERPRETATIONS**

Items 9341 and 9342 were test fired using factory ammunition and a reference collection magazine. No malfunctions were observed. The test fires were not retained in the laboratory.

JARED FORD, #10406, Forensic Scientist  
Central Regional Crime Laboratory  
2102 W. Encanto Blvd., Phoenix, AZ 85009  
602-223-2730 jford@azdps.gov

*Accredited by the ANSI National Accreditation Board (ANAB) to International Standards*

*Any notes, photographs, charts, or graphs generated during the examination are retained in the laboratory. Unless otherwise denoted, all evidence will be returned to the submitting agency. For additional information regarding laboratory policies visit*



ARIZONA DEPARTMENT OF PUBLIC SAFETY

FIELD DRUG TESTING RESULTS

Dr Number: <b>120003903</b>	Case Officer: REED, #7325
--------------------------------	------------------------------

**AGENCY** Arizona Department of Public Safety

**AGENCY NO.** 120003903

**SUSPECT INFORMATION**

**ITEMS TESTED**

Item No.	Description	Field Test Result	Usability
10096	Plant material	Marijuana	Usable quantity

The above item(s) were field tested. For each result, the field test was conducted on only one item or sub-item. If applicable, all other items were received, but not analyzed. If court testimony is required, the evidence will need to be resubmitted for complete laboratory confirmation analysis. Please contact the Controlled Substance Unit Supervisor at 602-223-2394 to arrange for further testing.

Field Tester's Name CAITLIN HAHN, #7887
--

Date March 09, 2020
------------------------

## Video/Audio Forensic Report

Incident Number: I20004289

Author: Detective J.E. Barahona #6801 AZ DPS

**Requesting Agency:**

AZ DPS Special Investigations Unit

**Requesting Agency DR #:**

I20003903

**Requestor:**

Detective A. Reed #7325

**Investigation Type:**

Officer Involved Shooting

*\* This report contains hyperlinks to supporting data and documentation; any printed copy of just this report is incomplete.*

**Requested Examination:**

On 01-22-2020, AZ DPS (CFU) Computer Forensics Sergeant D. Heltemes #6803 assigned CFU Detective Barahona #6801 to assist the AZ DPS Special Investigations Unit with a video forensic examination in reference to an officer involved shooting investigation. AZ DPS SIU Detective A. Reed #7325 completed an AZ DPS CFU Examination Request form asking for an export of all video files related to the Sedona Police Department Officer Involved Shooting investigation from three proprietary digital media storage devices.

On 01-22-2020 at approximately 0926 hours, AZ DPS SIU Detectives J. Fyfe #7460 and M. Van Tassel #7809 brought Items #MVC.1 9332, #MVB.1 9329, and #MVA.1 9327 to the AZ DPS CFU lab and transferred it to Det. Barahona for examination.

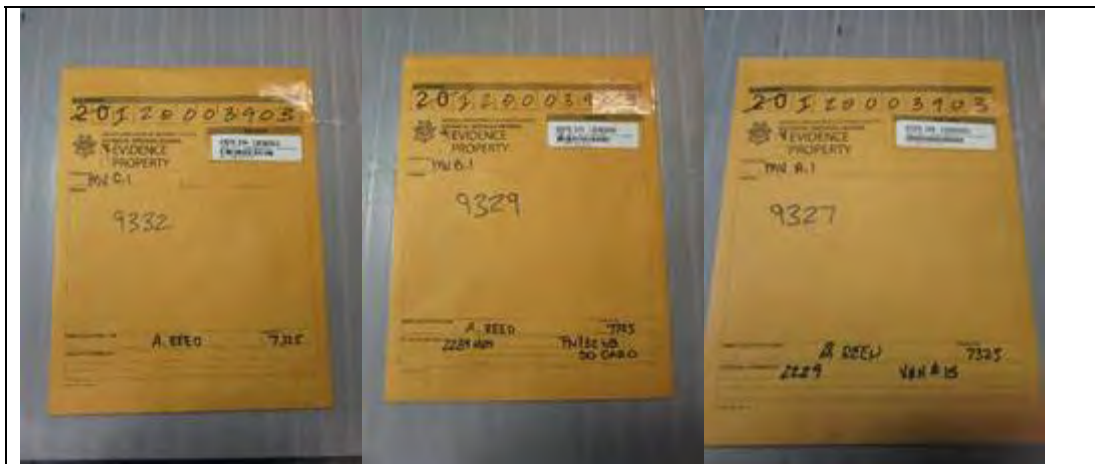

**Findings Summary:**

- Approximately (6) proprietary video files were located on Item #MVA.1 9327. The proprietary video files were found to contain 2 separate video files within each file. The (6) video files were converted to show the front and rear camera views, and a total of (12 MP4 video clips) were exported for the case detectives review.
- Approximately (5) proprietary video files were located on Item #MVB.1 9329. The proprietary video files were found to contain 2 separate video files within each file. The (5) video files were converted to show the front and rear camera views, and a total of (10 MP4 video clips) were exported for the case detectives review.

- Approximately (5) proprietary video files were located on *Item #MVC.1 9332*. The proprietary video files were found to contain 2 separate video files within each file. The (5) video files were converted to show the front and rear camera views, and a total of (10 MP4 video clips) were exported for the case detectives review.

**Evidence Items:**

- Item #MVC.1 9332*: FlashBack2 by L-3 Communications 8GB Compact Flash card. S/N #CF0231739



- Item #MVB.1 9329*: PNY Performance 32GB SD Card S/N #SDH32G04R00SHTC1D3DB3B



- Item #MVA.1 9327*: FlashBack2 by L-3 Communications 8GB Compact Flash card. S/N #CF01522



**PROGRAMS UTILIZED DURING THE EXAMINATION:**

- Microsoft Office 2010
- Microsoft Office 2010 Snipping Tool
- Digital Intelligence UltraBlock Forensic Card Reader

- Digital Intelligence USB 3.0 Forensic Card Reader
- AccessData FTK Imager v4.2.0.13
- AccessData FTK Imager v3.4.2.2
- Karen's Hasher v2.3.1
- L3 Flashback Converter v1.0.0.1

**Search Authority:**

Det. Fyfe stated *Items #MVC.1 9332, #MVB.1 9329, and #MVA.1 9327* were property of the Sedona Police Department whom gave verbal consent for the investigation.

**Physical Inspection:**

*Items #MVC.1 9332, #MVB.1 9329, and #MVA.1 9327* were photographed prior to the examination process. This documented the condition of the evidence. See [Examination Photos](#) for further.

**MD5/SHA1 Hash:**

*Items #MVC.1 9332, #MVB.1 9329, and #MVA.1 9327* were connected to write blocker devices (Digital Intelligence UltraBlock Forensic Card Reader and Digital Intelligence USB 3.0 Forensic Card Reader) and then connected to a forensic computer.

AccessData FTK Imager was utilized to create forensic images of *Items #MVC.1 9332, #MVB.1 9329, and #MVA.1 9327*. An MD5 and SHA1 hash value for the forensic images were generated. The hash values can be compared during future examinations to ensure the evidence was not altered during the examination process.

A SHA256 hash value was generated for all files on *Items #MVC.1 9332, #MVB.1 9329, and #MVA.1 9327* utilizing the hashing program Karen's Hasher. The files were copied to a forensic computer for processing and hashed again utilizing Karen's Hasher and the results compared. The hash values can be compared during future examinations to ensure the evidence was not altered during the examination process. See [Hash Files](#) for further.

**Time Validation:**

Not conducted.

**Evidence Identification:**

- *Item #MVA.1 9327*: Contained (6) proprietary QBX video files and (17) support files.

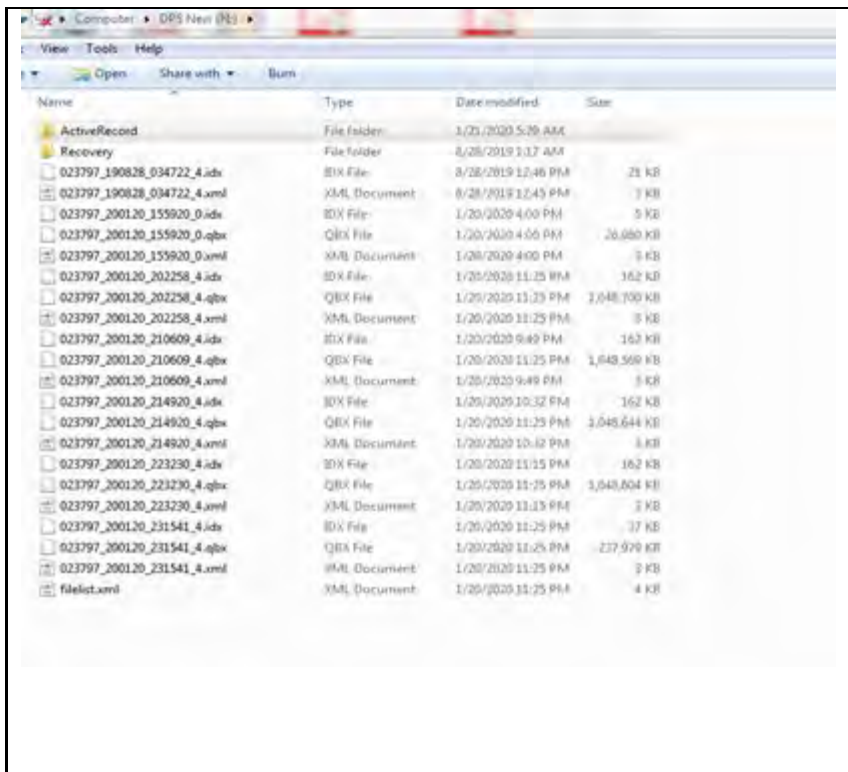

DPS000349

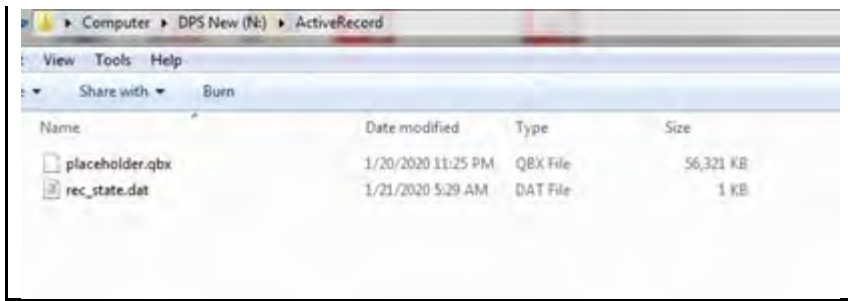

- Item #MVB.1 9329: Contained (5) proprietary QBX video files, (6) still images, and (24) support files.

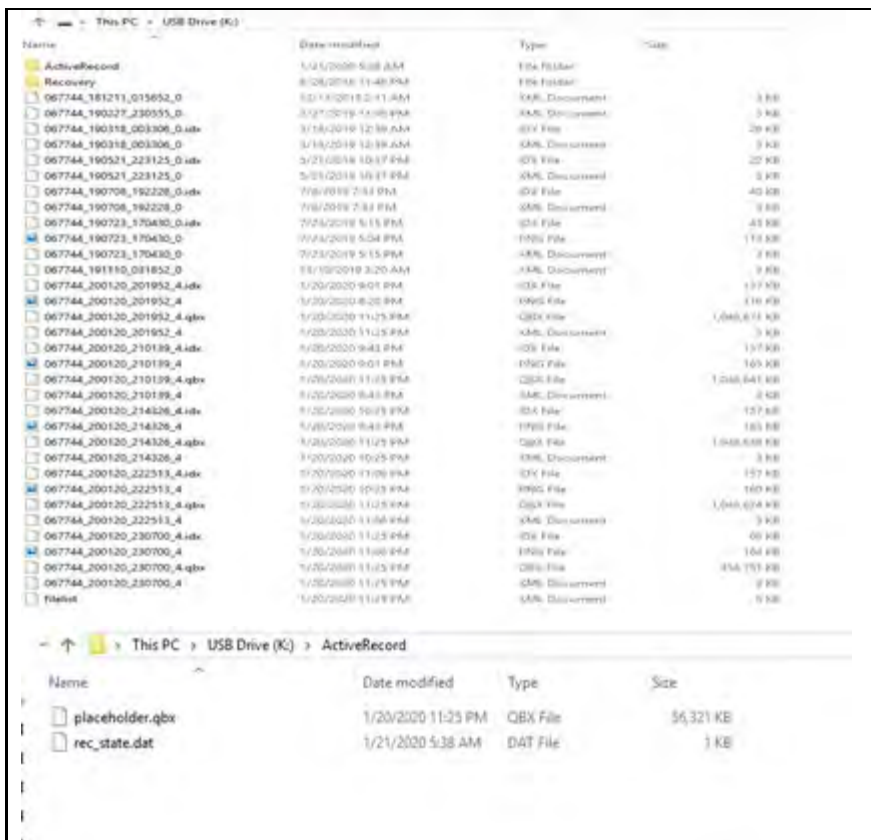

- Item #MVC.1 9332: Contained (5) proprietary QBX video files and (13) support files.





### Examination Processing:

Items ##MVA.1 9327, #MVB.1 9329, and #MVC.1 9332 all contained proprietary QBX video files that were not playable on any media device nor any forensic software. Det. Barahona made contact with a Technical Support Engineer with Mobile Vision (L3 Camera Communications Support Company) who was able to provide a proprietary software QBX to MP4 video converter (L3 Flashback Converter). The Technical Support Engineer also advised Det. Barahona that each QBX video file contains a front camera and rear camera view within one file.

Using the L3 Flashback Converter, all **16 QBX video files** were converted to a total of **32 MP4 video files** with the name of “Front” or “Rear” added to the original file name. See [Exported Videos](#) for further.



### Disposition:

- Items #MVA.1 9327, #MVB.1 9329, and #MVC.1 9332 were re-packaged and released back to Det. Fyfe on 01-23-2020.
- All **32 MP4 video files**, a copy of this report and all support documentation were sent to the case detective via electronic file sharing.

The Microsoft Windows program Snipping tool was utilized to capture graphics images from computer screens displaying notable information or file configurations. See [Screen Captures](#) for further details.



Detective J. Barahona #6801  
Arizona Department of Public Safety  
Computer Forensics Unit  
(602) 644-5971

## Glossary of Video Terms

<b>FPS</b>	<b>Frames Per Second</b>
<b>Resolution</b>	Generally quoted as width x height with units in pixels. Example 1024 x 768 would translate to 1024 lines of pixels and the height is 768 pixels.
<b>Pixel</b>	Smallest element of a picture
<b>Macro Block</b>	16 x 16 block of pixels (256 pixels total)
<b>Transform Blocks</b>	8 x 8 block of pixels (64 pixels total)
<b>DCT</b>	Discrete Cosine Transform – Algorithm used in JPEG image compression, MJPEG and MPEG video compression
<b>HDD</b>	Hard Drive Disk
<b>S/N</b>	Serial Number
<b>MD5 Hash Value</b>	(128-bit, 16 byte) Is a 32 string of characters uniquely identifying a file (Digital Fingerprint)
<b>DVR</b>	Digital Video Recorder
<b>MPEG</b>	Motion Picture Experts Group
<b>JPEG</b>	Joint Picture Experts Group
<b>Kbps</b>	Kilobytes Per Second
<b>Mbps</b>	Megabytes Per Second
<b>MAC address</b>	Media Access Control address
<b>HTML</b>	Hyperlink Markup Language – Web bases format used to hyperlink files
<b>EXIF</b>	Exchangeable Image File Format, a standard that specifies the formats for images, sound, and ancillary tags used by digital cameras (including smartphones), scanners and other systems handling image and sound files recorded by digital cameras. This can include GPS information.
<b>Metadata</b>	Data about data, most common are details in photographs (shutter settings, resolution, camera make)
<b>WAV File</b>	Windows Audio Volume, can be lossless compression
<b>MP3</b>	Motion Picture Experts Group Layer-3 lossy compression
<b>M=X N=X</b>	M= length between “P” frames N= length of GOP or “I” frames
<b>Compression</b>	The scientific method of removing the amount of information required to convey information.
<b>Forensics</b>	The scientific preserving, extracting, documenting and interpreting data for use in court.
<b>Codec</b>	Abbreviation for “Compressor” and “Decompressor” *See Compression also
<b>WMV file</b>	Windows Media Video file uses the ASF container format.
<b>Artifact</b>	Digital information added to the image as a result of compression or editing
<b>AVI file</b>	Audio Video Interleave file, developed by Microsoft for streaming video and audio files

DPS000352





CFU Incident Number: I20009033

Author: JT Easton #6115 DFU #1

**Requesting Agency:**

AZDPS

**Requestor:**

A. Reed #7325

**Requesting Agency DR #:**

I20003903

**Investigation Type:**

OIS

*\* This report contains hyperlinks to supporting data and documentation; any printed copy of just this report is incomplete.*

**Requested Examination:**

I received a request by the case detective to conduct a digital examination and/or extraction of the below listed evidence items. A copy of search warrant # 2020-000836 from the Superior Court of Maricopa was provided with the initial Computer Forensic Unit (CFU) examination request.

**Findings Summary:**

I was not able to extract any data on this device. The user area is encrypted. I tried many different techniques.

**Evidence Item:**

**Item 9334:**

CAT phone. Sprint SIM card was present. MSISDN: 5034804207.

**Physical Inspection and Imaging:**

A physical inspection of the evidence item(s) was completed and photographed.

**Lab Photos**

**Examination Procedures:**

1. The above listed item(s) were retrieved from the Arizona Department of Public Safety (DPS) Property and Evidence Section and transported to the Arizona Counter Terrorism Information Center (ACTIC).
2. The above listed evidence item(s) were inspected to document identification as noted above.
3. The phone(s) were taken into a Faraday tent, which shields the signal from connecting to the provider's network. Airplane Mode prevents connection to the service provider's network, preventing sending or receiving data. This item was placed into Airplane Mode.
4. The phone(s) were plugged into an appropriate battery-charging device prior to processing and the batteries charged to full capacity.

**Examination Results:**

**Item 9334:**

1. The phone's Subscriber Identification Module (SIM) card was removed from the handset to initially process separately using Cellebrite UFED 4PC version V7.28.2.8 The International Mobile Subscriber Identity (IMSI), Integrated Circuit Card Identity (ICCID), Mobile Station Integrated System Digital Number (MSISDN), tower information and potential contacts and SMS text information can be stored on the SIM. Cellebrite read the SIM card and a report was generated. [Item 9334 SIM card.](#)
2. The handset was attached to my forensic work station. Cellebrite and Magnet Axiom were used. Different methods were attempted to unlock the device. This device is not supported at this time with any of the tools available to me.

DPS000354

SD CARD IMAGES

All evidence was submitted back to the DPS Property and Evidence section for storage. A Liquid File (s) email was sent to the case detective.

*Jeffrey T. Easton*

Det. JT Easton # 6115  
Arizona Department of Public Safety  
Computer Forensics Unit  
(602) 644-5972



**ARIZONA DEPARTMENT OF PUBLIC SAFETY**  
**SUPPLEMENTAL REPORT**

<b>DR NUMBER:</b>	<b>I20003903</b>
-------------------	------------------

**SUMMARY:**

On Monday, January 20, 2020, I assisted the DPS Major Crimes District with the investigation of an officer-involved shooting at 55 Newcastle Lane in Sedona, Arizona.

**NARRATIVE:**

On 1/20/2020 at 1414 hours, I received a telephone call from DPS Highway Patrol Major J. Philpot, #4808. Major Philpot told me officers from the Sedona Police Department (SPD) had been involved in a shooting at the above listed address and SPD was requesting DPS conduct the investigation. Major Philpot requested the Northern Patrol Bureau Regional Advanced Collision Team (ReACT) respond to the scene to assist. I called out ReACT Troopers P. McCabe, #6512 and T. Humphrey, #7153 who agreed to respond.

I departed the Flagstaff DPS office at 1438 hours. I was diverted to an unrelated call at 1524 hours, as was Trooper Humphrey. Once clear, I arrived at the Newcastle crime scene at 1720 hours. A civilian member of SPD was maintaining the crime scene log and I checked in with him. I crossed the crime scene tape at approximately 1725 hours and spoke with Trooper McCabe and DPS Vehicular Crimes Unit Detective D. Sortor, #6400. Trooper McCabe told me he had already conducted an unmanned aerial system flight over the scene. I was also told he and Detective Sortor would measure and document the scene with a total station later in the night. I exited the crime scene at approximately 1750 hours (all times are accurately recorded on the crime scene log).

This ended my involvement in this investigation.

Trooper Name	ID No.	Location	Date	Supervisor
B.W. Elliott	5286	21000004	1/23/2020	J.P. Philpot, #4808



**ARIZONA DEPARTMENT OF PUBLIC SAFETY  
SUPPLEMENTAL REPORT**

<b>DR NUMBER:</b>	<b>I20003903</b>
-------------------	------------------

On January 20, 2020, at 1412 hours I, Arizona Department of Public Safety (AZ DPS) Detective Jared Gray, assigned to the Coconino Criminal Targeting Unit (CCTU) received a phone call from AZ DPS CCTU Sergeant Will Willis in-reference to an officer-involved-shooting in Sedona, Arizona. Sergeant Willis stated several officers from the Sedona Police Department (SPD) were involved in a critical incident. Sergeant Willis further elaborated detectives from AZ DPS Special Investigations Unit (SIU) were assigned as the lead investigators and they were on their way to Sedona. Sergeant Willis requested I respond to 55 New Castle Lane in Sedona to assist SIU with the investigation.

At 1434 hours, I left from Flagstaff and proceeded to Sedona. At 1537 hours, I arrived at 55 New Castle Lane. Upon my arrival, I met with SPD Sergeant (Sgt.) Nathan Dorfman who was parked in a fully marked patrol car outside of the outer crime scene. I introduced myself to Sgt. Dorfman and asked for a briefing of the events surrounding the investigation. Sgt. Dorfman stated SPD received a phone call from Cheryl Harrell (Harrell) regarding a white male with a mohawk trespassing. Harrell explained the trespasser was screaming and she believed he was involved in some kind of a ritual. Sgt. Dorfman explained the trespasser became confrontational with Harrell. (It should be noted Sgt. Dorfman did not provide further details regarding how the trespasser was confrontational). Police officers were dispatched to the scene. Shortly after their arrival, shots were fired, and the trespasser was struck by the gunfire. Medical personnel arrived on-scene and pronounced the subject deceased.

Sgt. Dorfman identified the deceased as Jonathan Messare (Messare) with a date-of-birth [REDACTED]. Sgt. Dorfman explained Messare was from Oregon. Sgt. Dorfman stated SPD officers have had prior contacts with Messare. Sgt. Dorfman stated based on those prior contacts it appeared Messare had some mental health issues. Sgt. Dorfman explained during prior contacts with Messare, he was aggressive with officers and did not law enforcement. Sgt. Dorfman explained an unknown officer from the SPD drafted an officer safety bulletin regarding Messare and sent it out via email to other officers from the SPD.

Sgt. Dorfman identified the officers involved in the shooting as: Sgt. Casey Palletier, Officer Bill Hunt and Kevin Hudspeth. Sgt. Dorfman stated the aforementioned officers had been removed from the scene and taken back to the SPD. Sgt. Dorfman then explained there were two witnesses to the incident. Sgt. Dorfman identified one of the witnesses as Harrell and could not provide the name of the other. Sgt. Dorfman said Harrell had been removed from the scene and was taken to a residence located at 47 Cypress Street. Sgt. Dorfman believed both witnesses had completed witness statements.

After speaking with Sgt. Dorfman, I proceeded to the inner crime scene where I met with SPD Lieutenant (Lt.) Lucas Wilcoxson and SPD Detective Sgt. Michael Dominguez. Lt. Wilcoxson was assigned as the incident commander (IC). Lt. Wilcoxson informed he had two written

Detective Name	ID No.	Location	Date	Supervisor
Jared Gray	7505	31010100	01/23/2020	Sgt. Will Willis, #6372



**ARIZONA DEPARTMENT OF PUBLIC SAFETY  
SUPPLEMENTAL REPORT**

<b>DR NUMBER:</b>	<b>I20003903</b>
-------------------	------------------

witness statements. He provided me with the statements, SPD dispatch call notes and a criminal history for Messare.

At 1555 hours, I entered the inner crime scene, Lt. Wilcoxson noted the time on the IC log. Sgt. Dominguez provided me with a brief walk through of the crime scene. Inside of the crime scene, I noted three fully marked SPD patrol vehicles pointed towards a retaining wall with Oak Creek on the other side. Located on the ground and on the driver side of the lead vehicle, I noted police tape marking several spent shell casings. In front of the patrol cars was a deceased subject covered by a white blanket. There were two vehicles from the Sedona Fire Department parked behind the marked SPD patrol cars. Sgt. Dominguez stated what he believed was a machete was recovered from the deceased after the shooting and it was secured in the back of an SPD patrol vehicle. Sgt. Dominguez walked me over to a patrol car, opened the rear hatch and showed me a white blanket with what he identified as the machete. The object was left alone, and rear hatch closed. Sgt. Dominguez concluded the walk through by informing all the SPD patrol cars were equipped with in-car cameras, which were still running. The in-car cameras were left running.

I cleared from the crime scene and again met with Sgt. Dorfman. Sgt. Dorfman informed me a vehicle located at 71B New Castle Lane was reported to belong to Messare. I walked over to the vehicle and obtained an Oregon registration of 367BZR. I was met by a neighbor located adjacent to 71B New Castle Lane. The neighbor informed me, he has seen Messare driving the vehicle and had been staying at 71B New Castle Lane. The neighbor informed me Peter McLoughlin is the tenant at 71B New Castle Lane. After receiving the information, a registration inquiry revealed the vehicle was registered to Hugh and Linda Boyanton with an address in Salem, Oregon.

Moments later, I met with AZ DPS SIU Sergeant Gunnar Hancock as he arrived on-scene. I provided Sgt. Hancock with the information provided to me by SPD officials on-scene. Sgt. Hancock was provided with the witness statements, criminal history, and SPD dispatch call notes.

Shortly thereafter, other SIU detectives arrived on-scene. Sgt. Hancock requested I provide them with briefing of the incident, which I did. Following the briefing, AZ DPS Detective Leo Karl and I were tasked with completing a neighborhood canvas for witnesses.

At 1730 hours, I knocked on the door of 65 New Castle Lane. No one answered the door.

At 1734 hours, I met with the resident of 75 New Castle Lane. The resident was verbally identified as Susan Frohman. Frohman was informed of who I was and the reason for the contact. Frohman was asked if she witnessed the incident. She informed me she observed a portion of the incident. Frohman explained she documented what she saw in writing. (It should be noted her statement was the second of the two provided to me by SPD Sgt. Dominguez). For further

Detective Name	ID No.	Location	Date	Supervisor
Jared Gray	7505	31010100	01/23/2020	Sgt. Will Willis, #6372



**ARIZONA DEPARTMENT OF PUBLIC SAFETY**  
**SUPPLEMENTAL REPORT**

<b>DR NUMBER:</b>	<b>I20003903</b>
-------------------	------------------

regarding Frohman's interview refer to her interview summary. I did not contact any other witnesses. The information provided to me by Frohman was provided to SIU investigators.

At 2044 hours, I cleared the scene and proceeded back to Flagstaff.

This concludes my involvement in this investigation.

Detective Name	ID No.	Location	Date	Supervisor
Jared Gray	7505	31010100	01/23/2020	Sgt. Will Willis, #6372



**ARIZONA DEPARTMENT OF PUBLIC SAFETY  
SUPPLEMENTAL REPORT**

<b>DR NUMBER:</b>	<b>I20003903</b>
-------------------	------------------

**SUMMARY:**

On Monday, January 20, 2020, I assisted the Arizona Department of Public Safety (DPS) Major Crimes District with the investigation of an officer-involved shooting at 55 Newcastle Lane in Sedona, Arizona.

**NARRATIVE:**

On January 20, 2020, at approximately 1415 hours, I received a telephone call from my supervisor, Sergeant B. Elliott, #5286. Sgt. Elliott advised me of an officer-involved shooting involving the Sedona Police Department, and our agency was being asked to assist with the investigation. I responded to the scene at 55 Newcastle Lane in Sedona and arrived at approximately 1555 hours. I walked to the scene and spoke briefly with DPS Sergeant G. Moran, #5603. After speaking with Sgt. Moran, I walked to the cordoned-off area, checked-in with Incident Command, and I entered the cordoned-off area to begin flight planning for aerial photography. I walked the perimeter of the area, moving along buildings on the west and northwest side, the bank of Oak Creek on the east side, and back along a fence line on the south end. After completing the perimeter planning, I stepped outside the cordoned-off area where I remained until additional unit with the Special Investigations Unit (SIU) arrived.

At approximately 1635 hours, I spoke with Captain R. Vega, #6264, and Detective K. Ellis, #6659. I advised them I had completed flight planning for the area and was prepared to do a flight when requested. I was given permission to begin the flight mission over the area, at which time, I retrieved my department-issued Unmanned Aerial System (UAS) from my patrol vehicle and prepared to complete the flight missions. With Detective L. Karl, #7618, serving as visual observer, I completed two grid-patterned flight patterns over the scene at 100 feet above ground level (AGL). During the missions, I obtained 217 aerial photographs. With the assistance of Detective Karl and Detective D. Sortor, #6400, I also completed a manual flight below trees in the area at various heights, obtaining an additional 49 photographs. I landed the UAS at approximately 1715 hours and exited the cordoned-off area.

I transferred the photographs onto my mobile data computer (MDC) and processed them into a single GeoTIFF picture. I provided the aerial photographs and subsequent GeoTIFF file to Detective Sortor for use in completing a scaled diagram.

I remained on-scene and later assisted Detective Sortor as he documented the scene utilizing a Leica Global Positioning System.

I cleared the scene at 2327 hours. This completed my involvement with this investigation.

Trooper Name	ID No.	Location	Date	Supervisor
P. J. McCabe	6512	21000004	01/24/2020	B. Elliott, #5286





**ARIZONA DEPARTMENT OF PUBLIC SAFETY  
SUPPLEMENTAL REPORT**

<b>DR NUMBER:</b>	<b>I20003903</b>
-------------------	------------------

**SUMMARY:**

On Monday, January 20, 2020, I assisted the DPS Major Crimes District with the investigation of an officer-involved shooting at 55 Newcastle Lane in Sedona, Arizona.

**NARRATIVE:**

On January 20, 2020 at 1345 hours, I received a telephone call from Sedona Police Chief Charles Husted. Chief Husted told me some of his officers had been involved in a shooting and asked if DPS could help with the shooting investigations. Chief Husted said his officers were not injured but he did not know the condition of the shooting victim and did not know the location of the exact location shooting. He advised he would call back soon, but he was in the Prescott area and would be driving to Sedona. He texted the address of the shooting location at 1352 hours.

I immediately called Major Manera, #4577, and provided him the information the Chief had relayed to me on our brief phone call. I then called Lieutenant Colonel Mitchell, #4303, and briefed her on the information. I next called Captain Seeley, #5208, briefed him and told him to send his closest supervisor to the scene so we could get some accurate information from the scene. I began responding to the scene and called Major Manera to determine if he would like our DUI/Command van and the Northern ReACT team. Major Manera said he would like the ReACT team but not the van. I called Sergeant Elliott, #5286, and asked him to respond with his ReACT units.

While driving to the scene I became involved in an unrelated urgent law enforcement incident, so I did not arrive on scene until approximately 1615 hours. I first with Sergeant Moran, #5603, and released him from the scene. I met with representatives from Sedona PD and the DPS investigations team and worked as a liaison with the Highway Patrol.

I exited the crime scene at approximately 1750 hours. (Both my arrival time and departure times from the scene are accurately recorded on the crime scene log).

This ended my involvement in this investigation.

Detective Name	ID No.	Location	Date	Supervisor
John Philpot	4808	21000001	1-23-19	LTC. Mitchell



**ARIZONA DEPARTMENT OF PUBLIC SAFETY  
SUPPLEMENTAL REPORT**

<b>DR NUMBER:</b>	<b>I20003903</b>
-------------------	------------------

**Summary:**

On 1/20/2020, members of the Sedona Police Department were involved in an officer-involved shooting at 55 Newcastle Lane in Sedona. The Arizona Department of Public Safety (DPS) Major Crimes district was contacted and requested to assist with the investigation of this incident. This is a summary of my involvement in this matter.

**Narrative:**

On 1/20/2020, I was contacted by Major Philpot at approximately 1348 hours, at which time Major Philpot advised me of this incident and he requested that I send a District 12 supervisor to the scene to act as the DPS liaison until Special Investigations Units (SIU) arrived.

I contacted Sergeant Moran #5603 at approximately 1349 hours, and I asked him to respond to the scene. At the time of my request, I did not have the address of the incident, but Sergeant Moran was able to ascertain that information.

At approximately 1523 hours, I departed the DPS office in Prescott and arrived in the area at approximately 1640 hours. At the intersection of Juniper Lane and Newcastle Lane, I encountered on-scene personnel who directed me to a dirt lot on the south-east corner of the intersection. There I observed several law enforcement vehicles staged in the lot. From there I continued on foot to the scene, where I encountered crime scene tape limiting access to the scene perimeters. I met with Major Philpot within the confines of the outer perimeter. I observed additional crime scene tape for the inner perimeter, which incapsulated several Sedona Police Department vehicles and a tarp covering what was identified as the suspect's body. At no time did I enter the inner perimeter of the scene.

While on scene, I met with members of Sedona Police Department command staff and inquired if they required additional assistance of uniformed personnel assigned to District 12. They advised at this time they did not, and I remained on scene in the event the Sedona Police Department and/or SIU required further assistance.

At approximately 1800 hours, I departed the area and returned to Prescott. This concludes my involvement in this incident.

Detective Name	ID No.	Location	Date	Supervisor
J. Seeley	5208	21120001	1/23/2020	Major Philpot



**ARIZONA DEPARTMENT OF PUBLIC SAFETY**  
**SUPPLEMENTAL REPORT**

<b>DR NUMBER:</b>	<b>I20003903</b>
-------------------	------------------

**SUMMARY:**

On January 20, 2020, I, Sergeant W. Willis #6372, supervisor for the Coconino Criminal Targeting Unit (CCTU), assisted the Arizona Department of Public Safety (AZ DPS) Major Crimes District with the investigation of an officer-involved shooting at 55 Newcastle Lane in Sedona, Arizona.

**NARRATIVE:**

On January 20, 2020 at approximately 1415 hours, I received a telephone call from AZ DPS Sergeant Erik Axlund #6158 (acting supervisor for the Northern Investigations Division). Sergeant Axlund informed me several officers from the Sedona Police Department (SPD) had been involved in a critical incident/shooting and AZ DPS was requested to conduct the investigation. Sergeant Axlund requested the CCTU respond to Sedona, Arizona to assist the Major Crimes District with the investigation.

I contacted CCTU Detective J. Gray #7505 and Detective L. Karl #7618, who responded to the scene. I responded to Sedona, AZ.

I arrived in the area of New Castle Lane at approximately 1545 hours, parking in a pre-designated field, away from the crime scene. Upon my arrival, I met with Detective Gray, who provided Special Investigations Unit (SIU) Sergeant G. Hancock #6775 and I a summary of the situation and events as he knew them at the time.

At approximately 1700 hours, I entered the inner perimeter where I was again provided a summary and a layout of the crime scene. While inside the perimeter, I maintained a distance from the vehicles away from the deceased individual and police vehicle, ensuring not to disrupt any potential evidence.

At approximately 1730 hours, I walked the exterior portion of the residence to the north of the perimeter and along the creek bed, looking for anything out of the ordinary and/or potential items of interest. I did not observe anything out of place or of interest.

I attended a summary brief, conducted by Detective Gray. Following the brief, I assigned Detective Gray and Detective Karl to conduct a neighborhood canvas for any potential witnesses. Refer to Detective Gray and Detective Karl's reports for further.

At approximately 1900 hours, Detective Karl and I proceeded to Copper Cliffs Drive, a neighborhood to the east and across the creek from the incident. Detective Karl and I attempted to contact two residences and a resort along Copper Cliffs Drive. Contact with the homeowners of the residences were unsuccessful. A walk around of the residence found no obvious signs of bullet holes and/or damage on the west/rear portions of the structures.

Trooper Name	ID No.	Location	Date	Supervisor
W. Willis	6372	31010100	1/27/2020	Sergeant E. Axlund 6158 (acting)



**ARIZONA DEPARTMENT OF PUBLIC SAFETY  
SUPPLEMENTAL REPORT**

<b>DR NUMBER:</b>	<b>I20003903</b>
-------------------	------------------

Detective Karl and I attempted to contact an employee and/or guests of the resort. The front lobby to the resort was closed and contact with any employees and/or guess was unsuccessful. A large portion of the resort appeared unoccupied and/or the lights were off. A walk around and inspection of the exterior portion of the resort found no obvious signs of bullet holes and/or damage to the west/rear portion of resort. Additionally, the resort appeared southwest of the incident and not in the immediate direction of the incident.

At approximately 2045 hours, I cleared the scene and proceeded back to Flagstaff, Arizona.

This ended my involvement in this investigation.

<b>Trooper Name</b>	<b>ID No.</b>	<b>Location</b>	<b>Date</b>	<b>Supervisor</b>
W. Willis	6372	31010100	1/27/2020	Sergeant E. Axlund 6158 (acting)

3:40

LTE



i am Jonny Legend Erassem a true Wa...



Jonathan David

January 2 at 8:17 PM



i am Jonny Legend Erassem a true War Chief Medicine  
man of the American fighting mighty men who stand  
against tyranny no matter where its found i will away  
be your brother I stand with u in this struggle suffer  
well when its your time to suffer  
Ill help you suffer well  
freedom fighters for liberty's glorious prize  
those willing to lay down them self in sacrifice for  
others liberation  
all who are oppressed suffering  
A plea goes out to all seekers  
those who seek the knowing an suffer thru will b  
rewarded w absolute truth  
stay the course till we blow the glass off the face of  
this place tear the roof off n see our nation return  
come home into healing the way back home is open  
the southern gate n home  
away this horrible course o boyos place a charge  
engage  
together as a tribe we break free of this hateful entity  
seed destroy its hypnotic control theorem  
enslavement of the populous false peace bring me  
pain so great it lead to an end of me broken so bad w  
no recovery you away hold me close an sing your  
healing winds over me  
im so weak an beaten down it becomes me my clarity  
immunity  
the changelings curse twisting word there definitive  
illusions of freedom a seed that reap destruction  
it would have you believe  
this illusion is reality truth is way bigger than you see  
only a fleeting shadowy image of the true nature of  
some freedom rings sounding thru the filter but its  
evidence  
strange fire keeps you from coming fully into your true  
self real fire destroy this strange .let go be broken  
weep mourn long for oneness inside yourself

3:40

LTE

< i am Jonny Legend Erasseem a true Wa...

not a schismed reality  
one w God Holy Predestine communion  
nothing is safe outside His will  
till we shake this face of lies there will b  
promises broken broken treaty trust betrayed  
we weep at the feet of its Slavery  
deeply the bondage we break  
this corruption of  
times times n half of times a plague  
blood of innocent demise  
writing on the wall displayed like evidence  
they've all been named  
marked for the harvest around the earth angels have  
marked men as in a blink of an eyelid  
sounds of great weeping gnashing of teeth  
hot blooded such heat well see as time an destiny  
meet  
the Determin Factor of  
this Great and Terrible day  
they go hand in hand on display for all to see no more  
secrets covenants tide to darkness subside broke  
never to be heard from again  
one blood one tribe one One Love one life for all  
mankind to reap his benefits  
krys resound from the earth domain martyrs blood  
demands righousess judgement justice rises up from  
the dust turning phoenix ashes a flame  
so sarrow will fade away  
as this war torn waste land error Eden gratifys to  
graves graves they made for the slaves while all His  
imortal soldiers rise take your place its almost over  
seems like 1000yr is a day a day  
the true purpose you were created for  
the hanging of the Whores of evil Laodicea daze  
to be fully through depravity  
ive been dazed and confused since the daze of my  
youth do to the wicths of disobedience  
i want to b obedient your will over my path of  
destruction  
not mine yours till ~~its done~~ you must in increase an i

3:41

LTE



i am Jonny Legend Erasseem a true Wa...

not mine yours till its done you must increase an i  
decrease till earths setting sun  
on earth as it is in heaven His government and peace  
will know no end only increases moment by moment  
breath by breath by breath  
i let go  
to have n to hold  
entrusting truth with all i am  
all hope  
all plans  
all control  
destroy controlling enemies  
foes who oppose Yahweh choose death by the sword  
see this battle before us plain as day an no man can  
sway or reshape my view change everything that is not  
of u burn away let the true flag of freedom ring  
the knowing  
yahs flow  
our nation has truly been enslaved to a corrupt fallen  
silent planet out of touch for so long from its core  
hope its creator God maker of all things seen an  
unseen the only one uncreated light of the universal  
display  
im ready to see the thing you shown me fully  
i still wait  
as i wait on you  
o Lord our healer  
defender of your universe  
come  
display your strength  
destroyer of those who would cause injury to his babes  
b a set apart people  
you can not earn His grace  
be stil n listen  
fall down in this broken place  
Elder is not a position its a head full of gray  
self sufficiency solo artist play  
soon youll be give over to your horror gorish infectious  
way disease breeders lie believers  
you will be eaten ~~by the dragons~~

3:41

LTE

< i am Jonny Legend Erasseem a true Wa...

you will be eaten by the dragons  
the sin eaters smell darkness runaway be afraid fear  
for your life because they will find you an they have no  
grace for u only the Pen Dragon an His named those  
he marked to save will be safe from there flames Esh  
nebicanessers path as your running away given over to  
your painful selfish desires but there will not be a  
happy ending as

His mighty Dragons will purify the land w the Esh  
Breath of Yahwah fire an sword what if dragons are  
real an they take 1000 yrs or more to hatch ?then that  
would be why we havent seen them they only wake up  
do there thing go home to lay eegs lets see what  
hapens next as this is not somthing ive heard of in  
church bet i heard it from the father so thats worth its  
your choice to belive it or not but the death beasts are  
coming the second passover be ready staff in hand an  
campin gear togtherlight an fast im pretty sure the  
dragons are going to stomp the shit out of the citys so  
the place to be is were nothing will fall an crush you  
the hearts of the fathers n eld

did you know chinees history has dragonsin it about  
2000 years ago crazy right ...make sure the blood of  
the lamb is on the door posrt of your hearts an they  
will pass over

the hearts of the fathers are turning to the childrens  
heart children who are fatherless will have home an  
never be afraid men be holy like as he is holy as deep  
as your fithe Holy Fire that is the creator feminine will  
sway an hold you in her motherly embrace like the  
rainbow her presence is a Promise i will increase n  
never decrees those who want me close you will get  
your hearts desire those who choose to harden there  
Heart to Him an choose Hatred over forgiveness you  
will be give over to your desire absents of His  
presence he has a place designed for your absence of  
him

o the joy of the Father to bring you up n in  
Hes been waitin preparing calling to u ive been trying  
to reaCH YOU ive ~~been justified an still~~ finding it hard



3:41

LTE

< i am Jonny Legend Erasseem a true Wa...

to reaCH YOU ive been justified an still finding it hard to breath in

Americas best war fighters good brothers braves on the war path for there family n homes righteously defending an preserving life from evil elements that will destroy the America we love devastation awaits the USA foren invaders plan to zero there all here an they have been in positions for many yrs as wars are waged in yrs not days all across the states

the gov will not be enough to fend of the foe there will be pockets of safty around the USA find like minded brothers an sisters to share life with protect each others hopes an plans as if they were your own i walked all over the PNW territory an saw that ther were no animals under 3000 elevation all the tracks go up deep into the deep the birds as well you may see some but as in the days of Noah so shall it be when the son of ma returns in His victorious splendor

we will have to come together as one I am the white buffalo this is fourth quarter of our time the truth judges hasverturned the word of the Lord is on the land his wind fills the bones and they become an army the Lord himself will strengthe for his presence w his people will only increase and never decrease and all who oppose him choose death by The sword see this Battle before us wthe eternal seperation of them from his presence those who want nothing to do with he will remove his presence from there excitannce a creation that is not in comunion w the creator gets sick an dies they do not evolve any more divorced his presence

A Manifesto of War writen as an account for measurement tearms to look into choices are be made for all

a line has been drawn an sides chosen due to broken treaty's b false promises lies from the beginning for Finanical gain an your truths lost

every man jugded on his own merit as a tree is known hv its fruit and seen hv all self-evident these truths are

3:42

LTE

< i am Jonny Legend ErasseM a true Wa...

obviously combat related injurys the drug gabapentin not comonly used for everything in the VA from antipsychotics 2 neuro injuries the more of their drugs you take the less of you remains the quicker you die from what I've gathered in my experience of watching these men eat these things that they're saying a good for them to eat will help their PTSD and south are issues and the killing them and they ate the men tre part of treatment plan eyes glossed can a man you used to know no longer exists just a shell of the former man is a mind erar drinformatie government is usin to redact informatin it could be a security threat it's no longer a black marker across the page butt drugs that Target specific areas they everythin within reach of the manhimself erase an eradicate to many sseduxs. and nausea and headaches brain injuries from coming through low-tech tribal places where community teaches children still have mothers and fathers and aunts and uncles cousins and nephews and nieces people are involved in each other's lives with family stories and traditions not isolated in box houses A tale of two cities box houses and Bedouin tribes Cain and Ab tribes take on marks of other they joined they take on atributes of each other our histories have been skewed to hide the truth from the American people to keep us ignorant in those in power in power an the people so busy they can't think straight let alone address probleM so so

They secure there money through evil pharmacy drugs that do not heal and only make sick like our foods made by the same people your healing an well bein not there priority your beIN sick busy an broke is more there cyclic concern

slavery of our children to high bi sex slaves human trafficking you loved by our high n might deal unjustly stealin evslavin family use the police to deliver drugs to deliver drugs 2 authorized dealers who work for gov ops also private security companies like blackwater an gov soldier s are beIN bout by the Sadi

Buying the cheapest equipment for your men to burn

3:42

LTE



i am Jonny Legend Erasseem a true Wa...

Buying the cheapest equipment for your men to burn to death in polyester made in China instead of good gear made by Americans perhaps by Filson or a Frost River canvas in wall if a burnable polyester when wars heat and fire extremes instead of giving us vehicles to carry equipment uses like mules damage our bodies and throw us away broken tools a broke nation that uses children whorin out it's men to do dirt for your political agendas whin to our own people for pharmaceutical food GMO agricultural the crossing of the Holy boundary freedom by use of control you police forces brutalize the homeless you can't garou courts rape our money hard-earned you keep us as slaves do they have enough money to put food on their families tables and pay the house excruciating high rents with no support when problems arise Our police forces Stormtroopers for dark agendas like highwaymen of old robb the people w murderous intimidation racism corruption to the core our cities government are run by sith lords and only the darkest entities move through the ranks like the Nazis awaiting the go order the manipulation of hidden things which are God's to know occult moves of darkness's seeking to devour I understand the phone line is comprised by a operations recording she cant talk why? Were are my kids? A cold war is comin to the door step in our time an im a dimond adversaries of the Creator is they fight against him they make war against him not that they going to win fighting against God's all part of God's plan it's all part of the story okay I take it there's apartment same f\*\*\*\*\* thing that's on the \$50 bill if that's true that's f\*\*\*\*\* crazy of it together what actually blow up the eagles game like this prophet predicted in this is start of the 45 days of darkness why do they drop dirty bomb in that b\*\*\*\* it's also the start of the plagues there's a there's a part in the video where you break it down and it shows you the Philadelphia stadium to get into enough well that's what I was talking about what if you really love her if

3:42

LTE

< i am Jonny Legend Erasseem a true Wa...

what I was talking about what if you really love her if you really love her have her lick your butthole why not it's fun get your salad tossed sometime don't judge my side of the fence until you have the balls to jump oh my God I love cigarettes I love you guys ready for this one this band's called ingested and either way I still needed to put these letters out for my heart for her and as a warning to you guys to know who you're f\*\*\*\*\* with you better think before you act and point guns at me ever again you should call Katie and tell her she needs to call me and she has permission to call me or else there's going to be repercussions on ur guard Ard of my temsif I don't talk to my wife and kids soon people will die not my people but maybe the people who are watching me baby just very important people who are working evil against America Like the obamas and clintons who enjoy eating children

Teams that are watching my men and our families are being watched IR teams you are going to get shot in the head by my SEAL teams and myn Green Rangers berets and the guys in the drones @ Wii control and those of you that f\*\*\*\*\* with our families your families will not be safe from our judgment of your house with our feathers we examine hunt with the children over claniin the carpets your children will be adopted into new family that will love a deep as the sense of home to homes as they are proud to be teach able that is if the sin-eater's don't eat them first she sand to the silenwar of the worlds and a lot of movies are coming in from outer world to our planet the resistance is strong the empire is evil saint Bernard no longer serve the empire the Ronin serve the cause of righteousness care for the aido ous pardnetter opresin God most ties with them we will defend America with spit on the war tribes for generations after we've come home from America's battles your VA hospital is killed us over and over in hordes you overdoses and simple surgeries and kill us you aren't trying to help soldiers you're just checking to see if the redactions are in

3:42

LTE

< i am Jonny Legend Erassem a true Wa...

you're just checking to see if the redactions are in place and what benefits you can strip from a body and his family so you can save a dollar you enabled darkness and her family's you have alliances with greys and other alien races that are evil and will be killed as well is technology in the earth that was planted here from before our time by outerworld Windows still interplanetary travel before the net went over our world because we are wartorn wasteland and the only way to be in this planet after the net when up was to be born which is why Jesus the first war chief of many brothers was born into this planet the water on our altar will burn bright you'll see fire and water together Ukraine new wine in New Orleans can make it through these days very near and close at hand we may see a civil war national disaster as well as an invading army as we have espionage teams all over our nation gathering Intel and your police departments don't see it because you're stupid and ill-trained too busy focused on hurting Americans and stealing out of our pockets like highwaymen and if you have not successfully started a civil war with your on me and all the veterans in America Walter Reed Walter Reed 190 dead Brothers up in a week for two years you tried to kill me awhile to read unsuccessfully in my wife saved my life which is why you planned this whole thing to get between me and my wife and separate us she saved my life over and over your correct I wouldn't be here without her and now I'm strong strong in the Lord continues to heal me and brake Ford actions that you have placed on My mind through drugs and witchcraft any drugs you are feeding my family need to stop immediately you giving them viruses they need antivirus has anything you've done to my family will come back on your own family's tenfold all the way back to your cousins and nephews and nieces I am not playing with you I am the pirate Johnny Legend infamous many nations just cuz you don't know me don't mean you know \*\*\* bout my

3:43

LTE

< i am Jonny Legend Erasseem a true Wa...

don't know me don't mean you know s\*\*\* bout my story my dossia will never play in the historie I don't work there ops with black teams I have a military ID from Boca chica when we lived in the keys I traveled àround the world with my wife and kids for 13 yrs ears around the country doing recon for my mission again this is my op I'm point eyewear the mohawk on this one ask Trump my confidant my I'd says I am not a civilian I'm a sergeante in combat arms field I have served my country proudly with honor and watch more than my share of men and boys died in the thousands around me there's good teams and bad teams in every uniform that believe in freedom and all the soldiers around the world my mother fought for freedom wherever there's trouble General issue job-oriented experts are raised on pain and sorrow if you test this Chester bridge the rollings will respond they watched as your police teams beat me and followed me and tracked me and poison me with bags of mollies and drugs they tried to kill me in Portland many times I was attacked by police officers I was handcuffed while they beat me and broke my bones do not get me water for days inside dry cells got a blood infection and high fevers and they let me come close to death continually beating me while I was in four-point restraints I have all the camera footage my men will have all that footage we watch you through your cell phones to because the tech that you're using against me is being used against you can we roll low-tack lately ask Master Chief funk he's a war chief up in the Pacific Northwest whether or not I'm salty I speak froggy very fluently pep boys in force recon all the way to delton inside the Pentagon resistance is made up of ex-presidents and millionaires you're not the only one with big pockets he owns the cattle on a thousand hills my crew where's the best war outfits your dudes with burn in your polyester suits are tasers will be repelled by our lovers f\*\*\*\*\* the French army n the French foreign legion which is full of soldiers who have ~~been burned by the~~ US government

3:43

LTE

< i am Jonny Legend Erasseem a true Wa...

soldiers who have been burned by the US government through the years can different operation teams throughout the generations stay with the foreign legion also have my back

the Polish teams excetera excetera Israel stands with me I'm American IDF my wife and kids are Jews if you are not with freedom and an exercise any form of control on the people li you did w my wife and kids you will have the full force of the IDF in your ass as she is a Royal bloodline of Hagen the founders of the IDF through Cohen her grandmothers which makes all my kids and my wife Jews so if you f\*\*\* with my Jews I f\*\*\* with you a promise from the IDF I'm n aplea ranger I swore an oath against all enemies foreign and domestic served in the army from 2000 to 2007 turn down Black ops multiple times can you tried to kill me and my men at time's even succeeded at killing all but me

Turbo movies made about me call sign jborn  
Jonny not Jason

the men who have talked to from the group's over the years they probably in town have risked their lives and doing so as they had taken vows to your dark teams to not betray the truth your covenants and sorcery comes to an end two trees came up together one righteous in one rotten clear or black these are your choices you kill people with heroin on our streets you support women and evil agendas to destroy their families instead of providing true Justice and judgments men are being put in jail without proof for walking on streets and living in woods you beat me all summer and followed me with drones in the department of national security teams sometimes it's deep is 200 cars and people in Portland seafood helicopters and had all sorts of s\*\*\* going on the day I so call The tack your police officers I did not I just matched with them I could have killed them I could have went to war right there I am highly trained in krav maga by the Israelis best I've been trained since I was a boy in Jiu-Jitsu kung fu taekwondo ~~taichuan~~ I am very much an

3:44

LTE

## < i am Jonny Legend Erasseem a true Wa...

kung fu taekwondo Tai chi I am very much an instructor and all levels of tactical anything I have read all the generals literatures war literatures dating back to all the wars in America and beyond Napoleon's letters I'm very schools in the arts of war and I am an artisan I am an artist for sure in many other forms as well no man longs for peace more than a warrior but he seen the bloodshed of battle and isn't afraid to do what he needs to do to defend freedom in those who can't defend themselves you've been lying to everybody saying we're good guys when really we've been hunting out tribes the scattered people from all around the world and killing out the tribal peoples with smallpox and diseases do you infect us with before we go and country is polluted our languages in our information streams over information does so we don't know what to believe effectively turn the people against each other black lives matter was to start a war in America and yet nobody's talking about that are they it was an operation against us when I went to school for Homeland security are network and firewalls are being hacked hundreds of thousands of times a day by China the people have to work 60 hours to be able to afford a house anywhere and there aren't any houses and you arrest us for sleeping in parks and state places without passes and registrations in taxing us heavily for the use of free public land this is Yvonne wrong and all the things that have been stacked against you or going to be listed is there is a list of names and those who do what they do will be exposed for the darkness that they do and those who are workers of light loss of the exposed and their deeds will be rewarded and those who stand with the resistance we stand with you when I was 16 they put me in jail as part of my training to learn how to fight and hate so they could use me in Africa to kill villagers that's why I we're cheetah I have made parlay with Africa my brother's. Medicine men an warrior tribes my medicine is strong in Africa it is the strongest in places ~~of deep suffering~~ the deeper The



3:44

LTE

< i am Jonny Legend Erasseem a true Wa...

strongest in places of deep suffering the deeper The suffering The more power I move in so effectively you're making me stronger for making me suffer more and more by not allowing me to talk to my wife and kids you threaten my family you've threaten me you've damaged my people your integrity is about to be be compassed upon yourselves you are to be given over to your own ways you will horror and Gore yourself to death f\*\*\*\*\* and eating each other till you die like a bunch of zombies Insanity will become you like Nebuchadnezzar and you will never recover unless you repent before the Lord to make no mistake the senators are coming and the Muslim armies are already staged and prepared and would lines and training with a case and rockets and hand grenades and your police departments are not going to be able to defend against it cuz they are bad guys for the most part did you not stand with the people so the people aren't going to stand with them if they get into trouble I had six cops point guns at me after you had my wife fill out lies on your restraining order 6 cops pulled me over for my special forces helmet and out-of-state plate they had VA handicap plates on it they made me push my bike home because I had a spec ops team Wendy helmet on and they pointed all their guns at me I cannot guarantee your safety next time you point guns at me my men may kill you they are over it and I will join The fray and die like a man I sang my songs I stayed my vigil before God and purified my heart and mind

he trains my hands for war and my fingers to fight I was a young boy like David when the Lord started using me in very real battles and the government tried to wipe out my mind your social workers would suck our little boy dicks as rewards your doctors of evil that experimented on children and I've been hurting people those who have done most evil be dealt with the harshest the longer it'll take for them to die than the rest slow long and brutal my men are experts they will make you suffer for your sins if the dragons don't eat

Marie Peoples, PhD, Chief Health Officer



---

**OFFICE OF THE MEDICAL EXAMINER**

*2500 N. Fort Valley Road  
Flagstaff, Arizona 86001  
TEL 928-679-8775  
FAX 928-779-7056*

**Name:** Messare, Jonathan

**Case #:** 20-047

**Date of Birth:** [REDACTED]

**Date of Death:** 01/20/2020

To Whom It May Concern:

Tissue samples and/or evidence collected during postmortem examination (see autopsy report for description of items retained) will be discarded one year after date of death unless other arrangements are requested by Law Enforcement.

Sincerely,

A handwritten signature in cursive script that reads "Lawrence Czarnecki, D.O.".

Lawrence Czarnecki, D.O.  
Chief Medical Examiner  
Coconino County Office of the Medical Examiner



**MEDICAL EXAMINER'S OFFICE**  
4402 E. Huntington Drive  
Flagstaff, Arizona 86004

**REPORT OF AUTOPSY**

---

**PATHOLOGIC DIAGNOSES**

- I. Gunshot wound, left side of chest, indeterminate range**
  - a. Entrance: above left nipple
  - b. Perforation of chest wall, left rib 5, left lung, pericardium and heart
  - c. Trajectory: front to back and downward
  - d. Medium caliber jacketed projectile recovered
- II. Gunshot wound, right-side of chest, indeterminate range**
  - a. Entrance: above right nipple
  - b. Perforation of chest wall, right rib 4, right lung, inferior vena cava and right rib 8
  - c. Trajectory: front to back, slightly left to right and downward
  - d. Medium caliber jacketed projectile recovered
- III. Graze gunshot wound of right flank, indeterminate range**
  - a. Perforation of skin and subcutaneous tissue of anterior abdominal wall
  - b. Trajectory: front to back and left to right
- IV. Gunshot wound of right lumbar region, indeterminate range**
  - a. Entrance: right lumbar region
  - b. Perforation of soft tissue of back and small bowel and penetration of anterior abdominal wall
  - c. Trajectory: back to front, slightly left to right and slightly upward
  - d. Medium caliber jacketed projectile recovered
- V. Gunshot wound of left shoulder, indeterminate range**
  - a. Entrance: lateral aspect of left shoulder
  - b. Perforation of soft tissue of left shoulder, comminuted fractures of left humerus and penetration of soft tissue back with fracture of left rib 9
  - c. Trajectory: left or right, downward and slightly front to back
  - d. Medium caliber jacketed projectile recovered
- VI. Gunshot wound of right upper arm, indeterminate range**
  - a. Entrance: front of right upper arm
  - b. Perforation of soft tissue of right upper arm
  - c. Exit: back of right upper arm

- d. **Trajectory: front to back, left to right and slightly upward**
- VII. **Mixed drug (methamphetamine/chlorpheniramine/dextromethorphan/cannabinoid) intoxication**
- VIII. **History of posttraumatic stress disorder with paranoia, depression and suicidal ideation**
- IX. **Brain donation to Boston University School of Medicine Chronic Traumatic Encephalopathy Center**
  - a. **History of traumatic brain injury in military**
  - b. **Reported history of childhood concussions**
  - c. **Reported history of ongoing cognitive defects and memory issues**

---

**CAUSE OF DEATH: Multiple gunshot wounds**  
**OTHER SIGNIFICANT CONDITIONS: Mixed drug (methamphetamine/chlorpheniramine/dextromethorphan/cannabinoid) intoxication, posttraumatic stress disorder with paranoia, depression and suicidal ideation, polysubstance abuse disorder, history of traumatic brain injury in military, history of childhood concussions**

**MANNER: Homicide**

### **REPORTED CIRCUMSTANCES OF DEATH**

According to reports, on January 20, 2020, this 41-year-old male was in a residential neighborhood where he was observed brandishing a machete and a stick. Law enforcement responded and repeatedly instructed the subject to drop his weapons. The decedent advanced toward police in a threatening manner and after failing to comply with instructions, was shot. He was pronounced dead at the scene at 1340 hours on January 20, 2020. The decedent had a history of posttraumatic stress disorder with paranoia, depression and suicidal ideation. He had a history traumatic brain injury in the military and a reported history of childhood concussions.

### **INTRODUCTION**

An autopsy is performed on a body identified as Jonathan Messare at the Coconino County Office of the Medical Examiner on the 23<sup>rd</sup> day of January, 2020 at 0900 hours. The body is received in a sealed plastic pouch with the seal number 2094841 (initial seal put on bag broke and was replaced with this seal).

The autopsy is attended by Andy Reed and Steve Kadelak (Arizona Department of Public Safety) and Brandon Bergstad (Sedona Police Department). The autopsy assistants are Starla Doss and Elizabeth Ross.

**EXTERNAL EXAMINATION**

The body is that of a well-developed, well-nourished adult Caucasian male, who weighs 245 pounds, is 71 inches in length, and appears compatible with the reported age of 41 years.

The body is received clad in 2 shoes, 2 socks, green pants with brown belt, camouflage vest, green vest, harness, black scarf, brown bracelet around right wrist and brown bracelet around left wrist. There are miscellaneous personal effects (see evidence sheet).

The wrists are handcuffed behind the lumbar region. Underlying the handcuffs are areas of horizontal indentations measuring up to  $3\frac{1}{2} \times \frac{3}{16}$  inch. Fingernail clippings are collected from the right and left hands.

There is a red Coconino County Office of the Medical Examiner identification band, bearing the decedent's name and case number, around the left ankle.

The unembalmed body is cool to the touch. Rigor mortis is set. Fixed red purple livor mortis extends over the posterior surfaces of the body, except in areas exposed to pressure. There is red suffusion of the face and neck.

The scalp hair is brown, worn in a Mohawk style and measures approximately 2 inches in length over the crown. The decedent wears a  $\frac{1}{4}$  inch in length brown mustache and beard. The irides are green. The pupils are bilaterally equal at 0.5 cm. The corneas are translucent. The sclerae and conjunctivae are unremarkable. No petechial hemorrhages are identified on the facial skin or bulbar or palpebral surfaces of the conjunctivae. There are two pierce marks within each ear lobe. The nose and lips are not unusual. The teeth are natural and in adequate condition. The neck is unremarkable.

The thorax is well developed and symmetrical. The abdomen is flat. The anus and back are unremarkable. The penis is circumcised. The testes are bilaterally descended within the scrotum.

The upper and lower extremities are well developed and symmetrical without absence of digits.

Identifying marks and scars include a vertically aligned 10 inch linear tattoo over the mid chin and front of the neck, a  $\frac{1}{2}$  inch linear scar on the lateral aspect of the left eyelid, a horizontally aligned 9 inch linear tattoo over the mid-aspect of the face, a 12 x 9 inch tattoo design consisting of a cross/"erassem"/horse design over the right upper arm, a  $4\frac{1}{2} \times 2$  inch dragon tattoo on the front of the right forearm, a  $6\frac{1}{2} \times 1$  inch "never die" tattoo over the back of the right forearm, a 2 inch cuff tattoo over the right wrist, a 4 inch tattoo over the back of the right hand and back of the right fingers consisting of lines and "live", a 12 x 5 inch flames and star design tattoo over the left upper arm, a  $4\frac{1}{2} \times 1$  inch "legend" tattoo over the medial aspect of the left upper arm, a 14 inch cuff tattoo over the right forearm and back the left hand consisting of "never change"/American flag/"free", a vertically aligned 4 inch linear scar over the mid back, a  $\frac{1}{4} \times \frac{1}{8}$  inch linear tattoo on the front of the right thigh, a  $1\frac{1}{4} \times \frac{3}{4}$  inch circular design tattoo on the right shin and a  $1 \times \frac{1}{2}$  inch illegible word tattoo on the right ankle.

Evidence of recent medical intervention includes electrocardiograph pads.

**EVIDENCE OF INJURY**

**HEAD AND NECK:** Over the right aspect of the forehead is a 2 ½ x ¼ inch area of red abrasions. Over the front of the nose is a 1 ¾ x ½ inch area of red abrasion. Over the left aspect of the forehead is a 2 x ¾ inch area of red abrasions.

**THORAX AND ABDOMEN:**Gunshot wound, left side of chest:

**Entrance:** Above the left nipple, 15 5/8 inches below the top of head and 5 ¾ inches left of the anterior midline is an entrance gunshot wound consisting of a ¼ inch round defect with a 1/8 inch circumferential marginal abrasion. The gunshot wound is centered within a 1 1/8 inch green red contusion. Soot, unburned gunpowder particles, and gunpowder stippling are not visible on the skin surrounding the wound.

**Path:** The hemorrhagic wound track sequentially perforates the anterior chest wall (fracturing left rib 5 with a ½ inch round defect), the left lung, the pericardium and the left ventricle of the heart. There are 900 mL blood with the left pleural cavity.

Recovered within the heart is a mushroomed yellow metal jacketed, medium caliber projectile.

**Trajectory:** The wound track travels from the decedent's front to back and downward.

**Clothing:** On the upper aspect of the left front pocket of the camouflage vest, 9 ¼ inches below the shoulder seam, is a 3/16 inch defect which passes through the double material of the pocket flap, the top of the large pocket, the top of the small pocket and the underlying front of the shirt (correlates with the region of the entrance gunshot wound). On the upper left front of the green vest, 10 ¼ inches below the shoulder seam, is a 3/16 inch defect which correlates with the region of the entrance gunshot wound. On the front left aspect of the black scarf are five defects measuring up to 7/8 inches.

Gunshot wound, right side of chest:

**Entrance:** Above the right nipple, 15 inches below the top of head and 6 ¼ inches right of the anterior midline is an entrance gunshot wound consisting of a ¼ inch round defect with a 1/8 inch circumferential marginal abrasion. The gunshot wound is centered within a 1 ¼ inch red contusion. At the medial aspect of the entrance gunshot wound is a 3/8 inch semicircular red abrasion. Soot, unburned gunpowder particles and gunpowder stippling are not visible on the skin surrounding the wound.

**Path:** The hemorrhagic wound track sequentially perforates the anterior chest wall (fracturing right rib 4 with a ½ inch round defect), the right lung, the inferior vena cava, and the posterior aspect of right rib 8. There are 800 mL of blood within the right pleural cavity.

Recovered within the subcutaneous tissue posterior to right rib 8 is a mushroomed yellow metal jacketed, medium caliber projectile.

Trajectory: The wound track travels from the decedent's front to back, slightly left to right and downward.

Clothing: On the upper right front of the camouflage vest are three defects, roughly in the region of the entrance gunshot wound. Two of the defects are above the right pocket, both measuring 8 inches below the shoulder seam and each measuring approximately  $\frac{3}{8}$  of an inch. The third defect is  $9\frac{1}{8}$  inch below the shoulder seam, measures  $\frac{3}{16}$  inches and passes through the double material of the pocket flap, the top of the pocket and the underlying front of the shirt. On the upper right front of the green vest,  $10\frac{3}{4}$  inches below the shoulder seam is a  $\frac{3}{16}$  inch defect which correlates with the region of the entrance gunshot wound.

Graze gunshot wound of right flank: On the upper right abdominal region,  $24\frac{1}{2}$  inches below the top of head and  $6\frac{1}{2}$  inches right of the anterior midline, is a graze gunshot wound consisting of a  $3\frac{1}{4}$  inch by up to 1 inch in width triangular defect with dried contused edges. The apex of the triangle is at the anterior aspect. The graze wound perforates the skin and subcutaneous tissue of the anterior abdominal wall and travels front to back and left to right.

Clothing: On the lower right front of the camouflage vest are two defects placed 17 inches below the shoulder seam ( $\frac{5}{8}$  inch defect) and  $18\frac{1}{2}$  inches below the shoulder seam ( $3\frac{7}{8}$  inch defect), both of which are in the region of the graze gunshot wound. On the lower right front and lateral aspect of the green vest are three defects which are in the region of the graze gunshot wound. From superior to inferior on the green vest, the defects are placed 19 inches below the shoulder seam ( $\frac{5}{16}$  inch defect),  $19\frac{1}{4}$  inches below the shoulder seam ( $\frac{3}{16}$  inch defect), and 24 inches below the shoulder seam ( $\frac{7}{8}$  inch defect).

Gunshot wound of right lumbar region:

Entrance: On the right lumbar region,  $28\frac{1}{4}$  inches below the top of head and  $2\frac{1}{4}$  inches right of the posterior midline is an entrance gunshot wound consisting of a  $\frac{1}{4}$  inch defect with a  $\frac{1}{32}$  inch red abrasion rim. Soot, unburned gunpowder particles and gunpowder stippling not visible on the skin surrounding the wound.

Path: The mildly hemorrhagic wound track sequentially perforates the soft tissue of the right lumbar region, the small bowel x 1 and penetrates the anterior right abdominal wall. There is a small amount of bowel contents within the peritoneal cavity and virtually no blood.

Recovered within the subcutaneous tissue, underlying a 1 inch green contusion of the anterior right abdomen,  $24\frac{1}{2}$  inches below the top of head, and  $2\frac{3}{4}$  inches right of the anterior midline, is a mushroomed, yellow metal jacketed medium caliber projectile.

Trajectory: The wound track travels from the decedents back to front, slightly left to right, and slightly upward.

Clothing: On the lower right back aspect of the camouflage vest,  $22\frac{3}{4}$  inches below the top of the collar is a  $\frac{5}{16}$  inch defect which correlates with the region of the entrance gunshot wound. On the lower right back aspect of the green vest,  $22\frac{3}{4}$  inches below the shoulder seam is a  $\frac{1}{4}$  inch defect which correlates with the region of the entrance gunshot wound.

UPPER EXTREMITIES: On the back of the left hand is a 1/16 inch healing brown abrasion and a 1/16 inch red abrasion. On the back of the left middle finger is a 1/16 inch healing brown abrasion.

Gunshot wound of left shoulder:

Entrance: On the lateral aspect of the left shoulder, 9 ½ inches below the top of head and 11 inches left the anterior midline is an entrance gunshot wound consisting of a ¼ inch round defect without marginal abrasion. Soot, unburned gunpowder particles and gunpowder stippling are not visible on the skin surrounding the wound.

Path: The hemorrhagic wound track perforates the soft tissue of the left shoulder with comminuted fractures of the proximal left humerus and penetrates the soft tissue of the back with a fracture of the posterior aspect of left rib 9.

Recovered, underlying a 5/8 inch red contusion of the mid-left aspect of the back, 17 inches below the top of head and 6 ¾ inches left of the posterior midline is a mushroomed, yellow metal jacketed medium caliber projectile.

Trajectory: The wound track travels from the decedent's left to right, downward and slightly front to back.

Gunshot wound of right upper arm:

Entrance: On the midline front of the right upper arm, 19 ¾ inches below the top of head is a ¼ inch round defect with a 1/16 inch red abrasion rim. Soot, unburned gunpowder particles and gunpowder stippling not visible on the skin surrounding the wound.

Path: The hemorrhagic wound track sequentially perforates the skin of the anterior right upper arm, the soft tissue of the lateral right upper arm and the skin of the posterior right upper arm.

Exit: On the posterior aspect of the right upper arm, 19 inches below the top of head and 1 inch right of the posterior midline is an exit gunshot wound consisting of a 1 inch laceration with an adjacent ¾ x ¼ inch red contusion and overlying stretch lacerations measuring up to ¼ inch.

Trajectory: The wound track travels from the decedent's front to back, left to right and slightly upward.

LOWER EXTREMITIES: None identified.



**INTERNAL EXAMINATION**

**BODY CAVITIES:** No adhesions are in any of the body cavities. All body organs are present in normal and anatomic position with absence of the gallbladder. The subcutaneous fat layer of the abdominal wall is 5 cm thick.

**HEAD:** No abnormalities of the scalp, skull or dura are present. The leptomeninges are thin and delicate. The brain weighs 1450 grams. The cerebral hemispheres are symmetrically well developed and have an anatomic gyral pattern without significant edema, atrophy, softening or discoloration. The Circle of Willis is normally distributed and appears patent. The brain is fixed in formalin and donated to Boston University School of Medicine Chronic Traumatic Encephalopathy (CTE) Center for further examination. The spinal cord is not examined.

**NECK:** Examination of the soft tissues of the neck, including strap muscles and large vessels, reveals no abnormalities. The hyoid bone and larynx are intact. The oropharynx is grossly normal and unobstructed. The laryngeal mucosa is smooth and unremarkable without petechiae. The tongue is normal.

**CARDIOVASCULAR SYSTEM:** The heart weighs 400 grams. The injuries have been previously described. The coronary arteries arise normally and follow the distribution of a right dominant pattern with no significant atherosclerotic stenoses. The chambers and valves bear the usual size/position relationship and are morphologically normal. The valve ring circumferences measure: tricuspid valve, 10 cm; pulmonic valve, 7 cm; mitral valve, 10.5 cm and aortic valve 6.5 cm. The valves are free of vegetations. The myocardium is dark red-brown, firm and unremarkable; the atrial and ventricular septa are intact. The left ventricle measures 1.2 cm, and the right ventricle measures 0.3 cm in thickness at 1 cm. below the valve annulus. The interventricular septum measures 1.2 cm. The aorta arises normally and follows the usual course with no significant atherosclerosis. The vena cava and major tributaries return to the heart in the usual distribution. There is no saddle embolus on in situ examination of the pulmonary trunk.

**RESPIRATORY SYSTEM:** The right and left lungs weigh 350 and 330 grams, respectively. Other than the previously described injuries, the pleural surfaces are smooth, glistening and unremarkable. The upper and lower airways are patent and the mucosal surfaces are smooth, yellow-tan, and unremarkable. The pulmonary parenchyma is dark red-purple and the cut surfaces exude moderate amounts of blood and frothy fluid. The pulmonary arteries are normally developed and patent.

**HEPATOBIILIARY SYSTEM:** The liver weighs 1790 grams. The hepatic capsule is smooth, glistening and intact, covering dark red-brown parenchyma. The gallbladder is not present and there are staples within the gallbladder bed. The extrahepatic biliary tree is patent.

**DIGESTIVE SYSTEM:** The esophagus is lined by gray-white smooth mucosa. The gastric mucosa is arranged in the usual rugal folds, and the lumen contains approximately 10 mL of light brown fluid. The appendix is present. The small bowel contains light brown fluid. The colon is unremarkable and contains light brown semi formed stool. The pancreas has a normal yellow-white lobulated appearance, and the ducts are clear.

**GENITOURINARY TRACT:** The right and left kidneys weigh 160 and 190 grams, respectively. The renal capsules strip with ease from the underlying smooth, red-brown, firm cortical surfaces. The cortices are of normal thickness and delineated from the medullary pyramids. The calyces, pelves, and ureters are unremarkable. The urinary bladder contains approximately 400 mL of

Messare, Johnathan

ME 20-047

clear, yellow urine; the mucosa is gray-tan and smooth. The prostate gland and seminal vesicles are unremarkable.

**RETICULOENDOTHELIAL SYSTEM:** The spleen weighs 110 grams and has a smooth intact capsule covering red-purple, soft parenchyma. The splenic lymphoid follicles are unremarkable. No abnormal lymph nodes are identified. The bone marrow of a thoracolumbar vertebral body is red-purple and homogeneous without evidence of focal abnormality. No thymus remnant is identified.

**ENDOCRINE SYSTEM:** The pituitary, thyroid and adrenal glands are unremarkable.

**MUSCULOSKELETAL SYSTEM:** Other than the previously described injuries, the bony framework, supporting musculature and soft tissues are not unusual.

### **MICROSCOPIC EXAMINATION**

**Brain:** Submitted to Boston University Medical Center Chronic Traumatic Encephalopathy (CTE) Center.

**Heart:** No significant histopathologic changes.

**Lungs:** Anthracosis; broncho-centric pigmented macrophages.

**Liver:** Mild chronic inflammation of portal triad regions.

**Spleen:** No significant histopathologic changes.

**Kidneys:** No significant histopathologic changes.

**Pancreas:** Autolysis.

### **ADDITIONAL STUDIES**

**TOXICOLOGY:** Postmortem toxicological analysis of chest cavity blood is positive for amphetamine (114 ng/mL), methamphetamine (1059 ng/mL), chlorpheniramine (594 ng/mL), cannabinoids (THC: 7.2 ng/mL, THC-COOH: 88.6 ng/mL), and dextromethorphan (2582 ng/mL). Postmortem toxicological analysis of urine is positive for amphetamine and methamphetamine and is negative for other drugs tested (see toxicology report).

**RADIOLOGY:** Radiographs demonstrate comminuted fractures of the proximal left humerus with radiopaque fragments. There are three deformed projectiles over the torso (fourth projectile from left aspect of back recovered before x-rays). There is orthopedic hardware over the T12-L1 region.

**EVIDENCE**

The following items are collected and preserved: blood tube, tissue biopsies, dried blood sample, pulled scalp hair.

The following items are collected and released to the Arizona Department of Public Safety: gray mit from left side pants pocket, black lighter and black sharpie from left front pants pocket, 2 miscellaneous cards/driver's license/VA ID/Visa card/miscellaneous paper/3 pennies/1 nickel/1 five dollar bill/miscellaneous metal piece from black pouch, black pouch with pipe and green substance, pipe and harmonica from right front pants pocket, mit from right side pants pocket, left shoe and sock, right shoe and sock, green pants and brown belt, handcuffs, camo vest, green vest, harness, black scarf, hat, 2 gloves/camo mask/black pouch/handcuff key/2 clips, black knife sheath and rope, 2 black belt straps, right brown bracelet, left brown bracelet, pipe and lighter from right bottom pocket of camo vest, miscellaneous metal piece from top right pocket of camo vest, right fingernail clippings, left fingernail clippings and clippers, projectile from subcutaneous aspect of left back, fingerprint card, projectile from right abdominal wall, blood blot, projectile from subcutaneous aspect of right back, projectile from heart, photo CD.

**OPINION**

Based on the autopsy findings and investigative history that is available to me, it is my opinion that, Jonathan Messare died as a result of multiple gunshot wounds. Other significant conditions included mixed drug (methamphetamine/chlorpheniramine/dextromethorphan/cannabinoid)) intoxication, posttraumatic stress disorder, depression, suicidal ideation, traumatic brain injury in military and reported history of childhood concussions.

The decedent was in a residential neighborhood where he was observed brandishing a machete and a stick. Law enforcement responded and repeatedly instructed the subject to drop his weapons. The decedent advanced toward police in a threatening manner and after failing to comply with instructions, was shot.

Autopsy revealed 6 gunshot wounds of indeterminate range, involving the torso and extremities. There were injuries of the heart and lungs with bleeding inside of the chest cavities. Postmortem toxicology revealed a mixed drug intoxication including methamphetamine, chlorpheniramine and dextromethorphan. The decedent was known to drink large quantities of Robitussin which contains dextromethorphan and chlorpheniramine.

The decedent's history included posttraumatic stress disorder, depression, suicidal ideation, traumatic brain injury in the military and a reported history of childhood concussions. The decedent's brain was donated to the Boston University School of Medicine Chronic Traumatic Encephalopathy Center.

The manner of death is homicide.

3/17/2020

Date Signed

*Lawrence A. Czarnicki, D.O.*

Lawrence A. Czarnicki, D.O.  
Medical Examiner



FORENSIC TOXICOLOGY

Testing Report
Web: www.axisfortox.com
Phone: (317) 759-4TOX

Table with laboratory case information and subject details. Includes Laboratory Case Number: 3186600, Subject's Name: MESSARE, JONATHAN, Client Account: 10026 / CCME01, Report To: Coconino County Med. Examiner, Agency Case #: 20-047, Date of Death: 01/20/2020, Test Reason: Other, Investigator: KB, Date Received: 01/24/2020, Date Reported: 02/10/2020.

Table with specimen and test information. Includes Laboratory Specimen No: 40837335, Date Collected: 01/23/2020 14:16, Container(s): 01:RTB Blood, PLEURAL, Test(s): 70531 Drugs of Abuse Extended Panel, Bloo

Main results table with columns: Analyte Name, Qualitative Result, Quantitative Result, Reporting Limit, Reference Range, Units, Note. Lists various analytes like VOLATILES, AMPHETAMINES, ANALGESICS, ANESTHETICS, etc., with their respective results and values.



FORENSIC TOXICOLOGY

Testing Report
Web: www.axisfortox.com
Phone: (317) 759-4TOX

Laboratory Specimen No: 40837335

Continued..

Table with 7 columns: Analyte Name, Qualitative Result, Quantitative Result, Reporting Limit, Reference Range, Units, Note. Rows include GASTROINTESTINALS, HALLUCINOGENS, MISCELLANEOUS, MUSCLE RELAXANTS, OPIOID ANALGESICS, Dextromethorphan, SEDATIVE/HYPNOTICS, STIMULANTS, and UROLOGICALS.

Specimens will be kept for at least one year from the date of initial report.



FORENSIC TOXICOLOGY

Testing Report
Web: www.axisfortox.com
Phone: (317) 759-4TOX

Laboratory Specimen No: 40837336 Date Collected: 01/23/2020 13:53
Container(s): 01:YTB Urine, Random Test(s): 80080 Basic Drugs of Abuse, Urine

Table with 7 columns: Analyte Name, Qualitative Result, Quantitative Result, Reporting Limit, Reference Range, Units, Note. Rows include AMPHETAMINES, BENZODIAZEPINES, BUPRENORPHINE/METABOLITE, CARISOPRODOL/METABOLITE, FENTANYL, METHADONE/METABOLITE, and OPIATES.

MESSARE, JONATHAN

Laboratory Case #: 3186600

Printed Date/Time: 02/10/2020, 12:51

DPS000390



FORENSIC TOXICOLOGY

Testing Report  
Web: [www.axisfortox.com](http://www.axisfortox.com)  
Phone: (317) 759-4TOX

Laboratory Specimen No: 40837336

Continued..

<u>Analyte Name</u>	<u>Qualitative Result</u>	<u>Quantitative Result</u>	<u>Reporting Limit</u>	<u>Reference Range</u>	<u>Units</u>	<u>Note</u>
Oxymorphone	Negative					
PHENCYCLIDINE	Negative					
Phencyclidine (PCP)	Negative					
TRAMADOL/METABOLITE	Negative					
Tramadol	Negative					
O-Desmethyltramadol	Negative					

MESSARE, JONATHAN

Laboratory Case #: 3186600

Printed Date/Time: 02/10/2020, 12:51

DPS000391



FORENSIC TOXICOLOGY

Testing Report  
Web: www.axisfortox.com  
Phone: (317) 759-4TOX

Laboratory Specimen No: 40837337

Date Collected: 01/23/2020 13:50

Container(s): 01:VIT\_CON Vitreous,EYE

Test(s): 49901 Volatiles Not Performed

Analyte Name	Qualitative Result	Quantitative Result	Reporting Limit	Reference Range	Units	Note
--------------	--------------------	---------------------	-----------------	-----------------	-------	------

< Volatile Testing Not Performed >

Due to negative blood, tissue, and/or urine volatile (Acetone, Ethanol, Isopropanol, and Methanol) results, volatile testing was not performed on the vitreous specimen.





FORENSIC TOXICOLOGY

Testing Report  
Web: www.axisfortox.com  
Phone: (317) 759-4TOX

Laboratory Specimen No: 40837338  
Container(s): 01:GRT Blood, PLEURAL

Date Collected: 01/23/2020 14:16  
Test(s): 49900 Not Tested

Analyte Name	Qualitative Result	Quantitative Result	Reporting Limit	Reference Range	Units	Note
< No Testing Performed	>					

The Specimen identified by the Laboratory Specimen Number has been handled and analyzed in accordance with all applicable requirements.

Laboratory Director

George S. Behonick, Ph.D., F-ABFT

MESSARE, JONATHAN

Laboratory Case #:3186600

Print Date/Time:02/10/2020, 12:51

Page: 6 of 6  
0393

Case Reviewer



ORR

# SEDONA POLICE DEPARTMENT Witness Statement

DR NUMBER  
-

WITNESS IS:  Victim  Relative  Other  
SUSPECT NAME (if known)?

LOCATION (STREET, HIGHWAY, MILEPOST, INTERSECTION)



NAME, LAST HARBELL FIRST Chewie MIDDLE Lynne

WITNESS INFORMATION

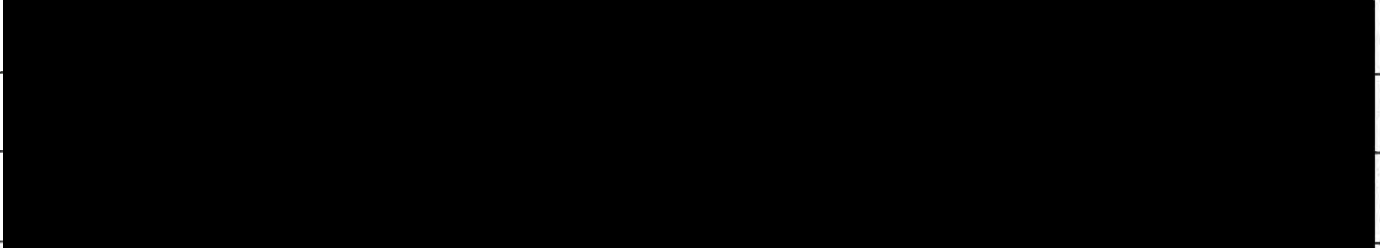

### SUSPECT DESCRIPTION

RACE: CAUCASIAN \_\_\_\_\_, BLACK \_\_\_\_\_, INDIAN \_\_\_\_\_, HISPANIC \_\_\_\_\_, ORIENTAL \_\_\_\_\_, MIDDLE EASTERN \_\_\_\_\_, OTHER \_\_\_\_\_

HEIGHT \_\_\_\_\_, WEIGHT \_\_\_\_\_, BUILD: SLIM \_\_\_\_\_, MEDIUM \_\_\_\_\_, HEAVY \_\_\_\_\_, OBESE \_\_\_\_\_, MUSCULAR \_\_\_\_\_, OTHER \_\_\_\_\_

HAIR: BLACK \_\_\_\_\_, BROWN \_\_\_\_\_, RED \_\_\_\_\_, BLOND \_\_\_\_\_, GREY OR GREYING \_\_\_\_\_, BALD OR BALDING \_\_\_\_\_,

LEIGHT: LONG \_\_\_\_\_, SHORT \_\_\_\_\_, SHOULDER \_\_\_\_\_, CREWCUT \_\_\_\_\_, STRINGY \_\_\_\_\_, OILY \_\_\_\_\_, STRIGHT \_\_\_\_\_, CURLY \_\_\_\_\_,

EYES: BLUE \_\_\_\_\_, BROWN \_\_\_\_\_, GREEN \_\_\_\_\_, HAZEL \_\_\_\_\_,

SIZE: LARGE \_\_\_\_\_, SMALL \_\_\_\_\_, FARSET \_\_\_\_\_, CLOSESET \_\_\_\_\_, SOUINTY \_\_\_\_\_, CROSSED \_\_\_\_\_, BLOODSHOT \_\_\_\_\_, WATERY \_\_\_\_\_,

GLASSES \_\_\_\_\_, OR CONTACTS \_\_\_\_\_,

FACE: ROUND \_\_\_\_\_, OVAL \_\_\_\_\_, EGG-SHAPED \_\_\_\_\_, SQUARE \_\_\_\_\_, /NECK: LONG \_\_\_\_\_, SHORT \_\_\_\_\_,

MUSTACHE \_\_\_\_\_, BEARD \_\_\_\_\_, GOATEE \_\_\_\_\_, SIDEBURNS \_\_\_\_\_, CLEAN SHAVEN \_\_\_\_\_, UNSHAVEN \_\_\_\_\_,

EYEBROWS: THIN \_\_\_\_\_, BUSHY \_\_\_\_\_, JOINED \_\_\_\_\_, OTHER \_\_\_\_\_, / EARS: LARGE \_\_\_\_\_, SMALL \_\_\_\_\_, PROTRUDING \_\_\_\_\_,

NOSE: THIN \_\_\_\_\_, LARGE \_\_\_\_\_, BROKEN \_\_\_\_\_, PUG \_\_\_\_\_, WIDE \_\_\_\_\_,

MOUTH: THIN LIPS \_\_\_\_\_, FULL LIPS \_\_\_\_\_, DIMPLES \_\_\_\_\_, OTHER \_\_\_\_\_,

TEETH: EVEN \_\_\_\_\_, SPACED \_\_\_\_\_, BROKEN \_\_\_\_\_, MISSING \_\_\_\_\_, METAL \_\_\_\_\_,

BREATH: SWEET \_\_\_\_\_, FOUL \_\_\_\_\_, ALCOHOL \_\_\_\_\_, SMOKERS \_\_\_\_\_,

CHIN: JUTTING \_\_\_\_\_, RECEDING \_\_\_\_\_, DIMPLED \_\_\_\_\_, POINTED \_\_\_\_\_, SQUARED \_\_\_\_\_,

COMPLEXION:

PALE \_\_\_\_\_, TANNED \_\_\_\_\_, COFFEE \_\_\_\_\_, RED \_\_\_\_\_, SMOOTH \_\_\_\_\_, OILY \_\_\_\_\_, ACNE \_\_\_\_\_, POKED \_\_\_\_\_, FRECKLED \_\_\_\_\_

SCARS:

FACE \_\_\_\_\_, TORSO \_\_\_\_\_

LEFT ARM / HAND: \_\_\_\_\_, RIGHT ARM / HAND \_\_\_\_\_

TATTOOS:

FACE \_\_\_\_\_, TORSO \_\_\_\_\_

LEFT ARM / HAND \_\_\_\_\_, RIGHT ARM / HAND \_\_\_\_\_

SUSPECT DESCRIPTION

ERICK HARRELL

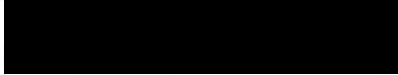

SEDONA POLICE DEPARTMENT  
Witness Statement

DR NUMBER

-

SPEECH: SLURRED \_\_\_\_\_, LISP \_\_\_\_\_, STUTTER \_\_\_\_\_, CLEFT \_\_\_\_\_

PALLET \_\_\_\_\_, RAPID \_\_\_\_\_, DRAWL \_\_\_\_\_, SOFT \_\_\_\_\_, MUMBLED \_\_\_\_\_, REFINED \_\_\_\_\_, ACCENT \_\_\_\_\_, OTHER \_\_\_\_\_

JEWELRY: EARRING(S) \_\_\_\_\_, WATCH: \_\_\_\_\_

NECKLEACE \_\_\_\_\_, RINGS \_\_\_\_\_

CLOTHING: NEAT \_\_\_\_\_, MUSSED \_\_\_\_\_, CLEAN \_\_\_\_\_, DIRTY \_\_\_\_\_, MASK / DISGUISE \_\_\_\_\_

HAT \_\_\_\_\_

SCARF \_\_\_\_\_

SHORT / LONG SLEEVE SHIRT \_\_\_\_\_

SHORTS / LONG PANTS \_\_\_\_\_

BELT \_\_\_\_\_

GLOVES \_\_\_\_\_

VEST \_\_\_\_\_

COAT \_\_\_\_\_

SHOES / BOOTS \_\_\_\_\_

BAREFOOT \_\_\_\_\_

JEWELRY: EARRING(S) \_\_\_\_\_, WATCH: \_\_\_\_\_

NECKLEACE \_\_\_\_\_, RINGS \_\_\_\_\_

WEAPON or INSTRUMENT: DESCRIBE, (LENGTH, FINISH, CALIBER, COLOR ETC)

AUTOMATIC: \_\_\_\_\_

REVOLVER: \_\_\_\_\_

SHOTGUN: \_\_\_\_\_

RIFLE: \_\_\_\_\_

KNIFE: \_\_\_\_\_

OTHER: machete & large stick

MODE OF TRAVEL: FOOT ←, BICYCLE \_\_\_\_\_, VEHICLE; DESCRIBE BELOW

DIRECTION OF TRAVEL: \_\_\_\_\_

WHAT WERE YOU DOING JUST PRIOR TO THE INCIDENT? Cleaning house

WHAT CALLED YOUR ATTENTION TO THE INCIDENT? (BREAKING GLASS, YELLING, SCREAMING GUN SHOT, ETC)

HOW FAR FROM AWAY FROM INCIDENT WERE YOU WHEN IT OCCURRED? screaming and yelling

HOW MANY PEOPLE WERE INVOLVED? 2 feet  
1 suspect  
1 victim

SEDONA POLICE DEPARTMENT  
Witness Statement

DR NUMBER

-

STATEMENT

Cleaning house heard yelling and looked out window  
SAW A MAN with a large machete and stick  
and a pit Bull

Walked near him to let him know he was  
on private property he appeared to not hear  
me and was chanting something he  
went to the retaining wall turned and  
chased me to the house yelling  
told his dog to get me. I hocked  
the door called 911 he went back to  
the retaining wall yelling and screaming  
and then sat down and took the  
machete across his chest several  
times all the time yelling  
Police arrived and he would not put  
the machete down the police shot  
him. End of Statement

Chayle Harrell

YOUR SIGNATURE

WITNESSED BY OFFICER

DATE

**SEDONA POLICE DEPARTMENT**  
**Witness Statement**

DR NUMBER
-

PLEASE DESCRIBE ANY VEHICLES INVOLVED IN THE INCIDENT

VEHICLE	COLOR	MAKE (FORD, CHEVY, ETC.)	MODEL (MUSTANG, CAMARO)	BODY STYLE (STATION WAGON, ETC.)
1				
2				
3				

**WEATHER CONDITIONS**

CLEAR  
  RAIN  
  SNOW  
  DUST  
  FOG  
  STRONG WINDS  
  CLOUDY  
  OTHER

**STATEMENT**

*[Handwritten statement text, mostly illegible due to blurriness and bleed-through]*

YOUR SIGNATURE \_\_\_\_\_ WITNESSED BY OFFICER \_\_\_\_\_



SEDONA POLICE DEPARTMENT  
Witness Statement

DR NUMBER  
-

WITNESS IS:  Victim  Relative  Other  
SUSPECT NAME (if known)?

LOCATION (STREET, HIGHWAY, MILEPOST, INTERSECTION)  
Newcastle Island

WITNESS INFORMATION  
NAME, LAST: Frohman  
FIRST: Susan  
MIDDLE: H  
CURRENT MAILING ADDRESS: [REDACTED]  
CITY: [REDACTED]  
STATE: [REDACTED]  
ZIP CODE: [REDACTED]

SUSPECT DESCRIPTION  
RACE: CAUCASIAN  , BLACK \_\_\_\_\_ , INDIAN ? \_\_\_\_\_ , HISPANIC \_\_\_\_\_ , ORIENTAL \_\_\_\_\_ , MIDDLE EASTERN \_\_\_\_\_ , OTHER \_\_\_\_\_  
HEIGHT 5'10 , WEIGHT 175 , BUILD: SLIM \_\_\_\_\_ , MEDIUM  , HEAVY \_\_\_\_\_ , OBESE \_\_\_\_\_ , MUSCULAR \_\_\_\_\_ , OTHER \_\_\_\_\_  
HAIR: BLACK \_\_\_\_\_ , BROWN  , RED \_\_\_\_\_ , BLOND \_\_\_\_\_ , GREY OR GREYING \_\_\_\_\_ , BALD OR BALDING \_\_\_\_\_ ,  
LEIGHT: LONG \_\_\_\_\_ , SHORT \_\_\_\_\_ , SHOULDER \_\_\_\_\_ , CREWCUT  , STRINGY \_\_\_\_\_ , OILY \_\_\_\_\_ , STRIGHT \_\_\_\_\_ , CURLY \_\_\_\_\_ ,  
EYES: BLUE \_\_\_\_\_ , BROWN \_\_\_\_\_ , GREEN \_\_\_\_\_ , HAZEL \_\_\_\_\_ , Spiked  
SIZE: LARGE \_\_\_\_\_ , SMALL \_\_\_\_\_ , FARSET \_\_\_\_\_ , CLOSESET \_\_\_\_\_ , SOUINTY \_\_\_\_\_ , CROSSED \_\_\_\_\_ , BLOODSHOT \_\_\_\_\_ ,  
WATERY \_\_\_\_\_ ,  
GLASSES \_\_\_\_\_ , OR CONTACTS \_\_\_\_\_  
FACE: ROUND \_\_\_\_\_ , OVAL \_\_\_\_\_ , EGG-SHAPED \_\_\_\_\_ , SQUARE \_\_\_\_\_ , /NECK: LONG \_\_\_\_\_ , SHORT \_\_\_\_\_ ,  
MUSTACHE \_\_\_\_\_ , BEARD \_\_\_\_\_ , GOATEE \_\_\_\_\_ , SIDEBURNS \_\_\_\_\_ , CLEAN SHAVEN \_\_\_\_\_ , UNSHAVEN \_\_\_\_\_ ,  
EYEBROWS: THIN \_\_\_\_\_ , BUSHY \_\_\_\_\_ , JOINED \_\_\_\_\_ , OTHER \_\_\_\_\_ , / EARS: LARGE \_\_\_\_\_ , SMALL \_\_\_\_\_ , PROTRUDING \_\_\_\_\_ ,  
NOSE: THIN \_\_\_\_\_ , LARGE \_\_\_\_\_ , BROKEN \_\_\_\_\_ , PUG \_\_\_\_\_ , WIDE \_\_\_\_\_ ,  
MOUTH: THIN LIPS \_\_\_\_\_ , FULL LIPS \_\_\_\_\_ , DIMPLES \_\_\_\_\_ , OTHER \_\_\_\_\_ ,  
TEETH: EVEN \_\_\_\_\_ , SPACED \_\_\_\_\_ , BROKEN \_\_\_\_\_ , MISSING \_\_\_\_\_ , METAL \_\_\_\_\_ ,  
BREATH: SWEET \_\_\_\_\_ , FOUL \_\_\_\_\_ , ALCOHOL \_\_\_\_\_ , SMOKERS \_\_\_\_\_ ,  
CHIN: JUTTING \_\_\_\_\_ , RECEDING \_\_\_\_\_ , DIMPLED \_\_\_\_\_ , POINTED \_\_\_\_\_ , SQUARED \_\_\_\_\_ ,  
COMPLEXION:  
PALE \_\_\_\_\_ , TANNED \_\_\_\_\_ , COFFEE \_\_\_\_\_ , RED \_\_\_\_\_ , SMOOTH \_\_\_\_\_ , OILY \_\_\_\_\_ , ACNE \_\_\_\_\_ , POKED \_\_\_\_\_ , FRECKLED \_\_\_\_\_  
SCARS:  
FACE \_\_\_\_\_ , TORSO \_\_\_\_\_  
LEFT ARM / HAND: \_\_\_\_\_ , RIGHT ARM / HAND \_\_\_\_\_  
TATTOOS: Yes  
FACE \_\_\_\_\_ , TORSO \_\_\_\_\_  
LEFT ARM / HAND \_\_\_\_\_ , RIGHT ARM / HAND \_\_\_\_\_

SEDONA POLICE DEPARTMENT  
**Witness Statement**

DR NUMBER

-

SPEECH: SLURRED  , LISP \_\_\_\_\_ , STUTTER \_\_\_\_\_ , CLEFT \_\_\_\_\_

PALLET \_\_\_\_\_ , RAPID \_\_\_\_\_ , DRAWL \_\_\_\_\_ , SOFT \_\_\_\_\_ , MUMBLED  , REFINED \_\_\_\_\_ , ACCENT \_\_\_\_\_ , OTHER \_\_\_\_\_

JEWELRY: EARRING(S) \_\_\_\_\_ , WATCH: \_\_\_\_\_

NECKLEACE \_\_\_\_\_ , RINGS \_\_\_\_\_

CLOTHING: NEAT \_\_\_\_\_ , MUSSED \_\_\_\_\_ , CLEAN \_\_\_\_\_ , DIRTY  , MASK / DISGUISE \_\_\_\_\_

HAT \_\_\_\_\_

SCARF \_\_\_\_\_

SHORT / LONG SLEEVE SHIRT \_\_\_\_\_

SHORTS / LONG PANTS \_\_\_\_\_

BELT \_\_\_\_\_

GLOVES \_\_\_\_\_

VEST \_\_\_\_\_

COAT \_\_\_\_\_

SHOES / BOOTS \_\_\_\_\_

BAREFOOT \_\_\_\_\_

JEWELRY: EARRING(S) \_\_\_\_\_ , WATCH: \_\_\_\_\_

NECKLEACE \_\_\_\_\_ , RINGS \_\_\_\_\_

**WEAPON or INSTRUMENT: DESCRIBE, (LENGTH, FINISH, CALIBER, COLOR ETC)**

AUTOMATIC: \_\_\_\_\_

REVOLVER: \_\_\_\_\_

SHOTGUN: \_\_\_\_\_

RIFLE: \_\_\_\_\_

KNIFE: \_\_\_\_\_

OTHER: \_\_\_\_\_

MODE OF TRAVEL: FOOT \_\_\_\_\_ , BICYCLE \_\_\_\_\_ , VEHICLE; DESCRIBE BELOW

DIRECTION OF TRAVEL: \_\_\_\_\_

WHAT WERE YOU DOING JUST PRIOR TO THE INCIDENT? *Sitting on Patio*

WHAT CALLED YOUR ATTENTION TO THE INCIDENT? (BREAKING GLASS, YELLING, SCREAMING, GUN SHOT, ETC)

*Indian chanting/yelling w a feathered stick*

HOW FAR FROM AWAY FROM INCIDENT WERE YOU WHEN IT OCCURRED? *100 feet*

HOW MANY PEOPLE WERE INVOLVED?

*just heard chanting + saw man sitting on creek wall chanting/yelling - Then heard gunshots.*

SEDONA POLICE DEPARTMENT  
Witness Statement

DR NUMBER

-

STATEMENT

At about 1:30 pm I returned a 3 legged pit bull to a cabin on Newcastle lane. Two young "high" men took the dog from me.

Then I was sitting on my patio and heard ~~the~~ chanting + yelling. I turned to see where it was coming from + saw the bigger of the two men sitting on the retaining wall chanting with an "Indian" type of stick w feathers. He was raising it above his head.

Then I heard about 5 gunshots + raced into the house + dialed 911. They informed me an officer was on scene + I should stay in the house.



SEDONA POLICE DEPARTMENT  
**Witness Statement**

DR NUMBER
—

PLEASE DESCRIBE ANY VEHICLES INVOLVED IN THE INCIDENT

VEHICLE	COLOR	MAKE (FORD, CHEVY, ETC.)	MODEL (MUSTANG, CAMARO)	BODY STYLE (STATION WAGON, ETC.)
1				
2				
3				

**WEATHER CONDITIONS**  
 CLEAR    RAIN    SNOW    DUST    FOG    STRONG WINDS    CLOUDY    OTHER

**STATEMENT**

Lined area for writing the witness statement.

YOUR SIGNATURE \_\_\_\_\_ WITNESSED BY OFFICER \_\_\_\_\_

# PRESS HARD - YOU ARE MAKING 5 COPIES

FOR BEST COPIES - REMOVE FROM BOOK AND WRITE ON A HARD SURFACE



## VICTIM REQUEST FOR, OR WAIVER OF, PRE-CONVICTION AND / OR PRE-ADJUDICATION RIGHTS

This form opts you in as a victim because there is probable cause that a crime has been committed against you. Opting in does not mean you are "pressing charges." Please keep this form for future reference regarding your case.

<b>1</b>	<b>&lt;&lt;FORM USE&gt;&gt;</b>	
<input type="checkbox"/> Initial Contact	<input checked="" type="checkbox"/> By Phone/Mail	DATE: 01/20/2020
<input type="checkbox"/> Victim-Initiated Change(s)	<input type="checkbox"/> In Person	

### 2 <<CASE IDENTIFYING INFORMATION>>

REPORTING AGENCY: Arizona Department of Public Safety Phone #: 602-223-2000  
Reporting Officer(s): A. Reed Complaint/Report/Citation #: I20003903  
Location: 55 New Castle Lane Report/Citation Date/Time: 01/20/2020 1700  
Offense/Type of Crime: Aggravated Assault  
 Felony    Misdemeanor    Petty Offense    Domestic Violence Issue

### 3 <<ARREST / DETENTION STATUS>>

<input type="checkbox"/> SUSPECT NOT IN CUSTODY <input type="checkbox"/> UNKNOWN <input type="checkbox"/> KNOWN <input type="checkbox"/> ADULT <input type="checkbox"/> JUVENILE SUSPECT #1 _____ DOB _____ SUSPECT #2 _____ DOB _____ If an arrest/detention in this case is made, you will be notified at the earliest opportunity. If you are not notified of an arrest/detention within 30 days, you may obtain case status information by calling the law enforcement agency indicated in Box 2 above.	<input type="checkbox"/> SUSPECT CITED AND RELEASED / REFERRED ADULT <input type="checkbox"/> JUVENILE <input type="checkbox"/> SUSPECT #1 _____ DOB _____ SUSPECT #2 _____ DOB _____ COURT _____ DATE: _____ TIME: _____ If a citation is issued, the accused may appear at any time prior to the date and time shown.	<input checked="" type="checkbox"/> SUSPECT IN CUSTODY - ADULT INITIAL APPEARANCE: SUSPECT #1 <u>Jonathan David Messare</u> DOB <u>[REDACTED]</u> SUSPECT #2 _____ DOB _____ COURT <u>DECEASED</u> DATE: _____ TIME: _____ CUSTODIAL AGENCY: _____ The adult suspect in custody will appear in court for an Initial Appearance within 24 hours of arrest.	<input type="checkbox"/> SUSPECT IN CUSTODY - JUVENILE DETENTION HEARING: SUSPECT #1 _____ DOB _____ SUSPECT #2 _____ DOB _____ DETENTION CENTER: _____ The juvenile suspect in custody will appear for a Detention Hearing at the county Juvenile Court or Detention Center within 24 hours of detention, but may be released at any time prior to this hearing.
---	--	---	--

### 4 <<VICTIM OR VICTIM'S LAWFUL REPRESENTATIVE>>

A. Who was the crime or offense committed against?  
Victim: Cheryle Harrell Sex:  M  F Birth Date: [REDACTED]

B. Lawful Representative: \_\_\_\_\_ Sex:  M  F Birth Date: \_\_\_\_\_ Relationship to Victim: \_\_\_\_\_

- If lawful representative, check (one) of the following which applies:
- The victim has designated me as his/her lawful representative.
  - The victim is incapacitated or deceased and I am an immediate family member.
  - The victim is a legal entity (corporation, partnership or business).
  - The victim is minor child and I am a parent, an immediate family member or legal guardian.
  - The victim is a vulnerable adult & I am the legal guardian.

C. How can you be contacted? What is your language preference?  English    Spanish    \_\_\_\_\_

Name: Cheryle Harrell  
Mailing Address: [REDACTED] Apt: \_\_\_\_\_  
Home Address (if different): \_\_\_\_\_ Apt: \_\_\_\_\_  
City: [REDACTED] State: [REDACTED]  
Telephone: (Primary) [REDACTED] (Alternate/Message) \_\_\_\_\_  
Email: \_\_\_\_\_

D. <input checked="" type="checkbox"/> I REQUEST my rights in this case.   OR <input type="checkbox"/> I WAIVE (DECLINE) my rights in this case. I understand that I must keep my mailing address and phone number current with the agency or court responsible for providing my rights. Failure to do so can mean that my rights are waived. I also understand in order to make any changes to the information supplied on this form, I must contact the appropriate agency or court.	(FOR REPORTING AGENCY USE ONLY) <input type="checkbox"/> REQUEST / WAIVER exception per A.R.S. § 13-4405(B) and § 8-386(B)	NOTES / COMMENTS:
Victim or Lawful Representative Signature / Date: <input checked="" type="checkbox"/> _____		

# PRESS HARD - YOU ARE MAKING 5 COPIES

FOR BEST COPIES - REMOVE FROM BOOK AND WRITE ON A HARD SURFACE



## VICTIM REQUEST FOR, OR WAIVER OF, PRE-CONVICTION AND / OR PRE-ADJUDICATION RIGHTS

This form opts you in as a victim because there is probable cause that a crime has been committed against you.  
Opting in does not mean you are "pressing charges."  
Please keep this form for future reference regarding your case.

**1** <<FORM USE>>  
 Initial Contact       By Phone/Mail      DATE: 01/20/2020  
 Victim-Initiated Change(s)       In Person

### 2 <<CASE IDENTIFYING INFORMATION>>

REPORTING AGENCY: Arizona Department of Public Safety Phone #: 602-223-2000  
Reporting Officer(s): A. Reed Complaint/Report/Citation #: I20003903  
Location: 55 New Castle Lane Report/Citation Date/Time: 01/20/2020 1700  
Offense/Type of Crime: Officer Involved Shooting  
 Felony     Misdemeanor     Petty Offense     Domestic Violence Issue

### 3 <<ARREST / DETENTION STATUS>>

<input type="checkbox"/> SUSPECT NOT IN CUSTODY <input type="checkbox"/> UNKNOWN <input type="checkbox"/> KNOWN <input type="checkbox"/> ADULT <input type="checkbox"/> JUVENILE SUSPECT #1 _____ DOB _____ SUSPECT #2 _____ DOB _____ If an arrest/detention in this case is made, you will be notified at the earliest opportunity. If you are not notified of an arrest/detention within 30 days, you may obtain case status information by calling the law enforcement agency indicated in Box 2 above.	<input type="checkbox"/> SUSPECT CITED AND RELEASED / REFERRED ADULT <input type="checkbox"/> JUVENILE <input type="checkbox"/> SUSPECT #1 _____ DOB _____ SUSPECT #2 _____ DOB _____ COURT _____ DATE: _____ TIME: _____ If a citation is issued, the accused may appear at any time prior to the date and time shown.	<input checked="" type="checkbox"/> SUSPECT IN CUSTODY - ADULT INITIAL APPEARANCE: SUSPECT #1 <u>Jonathan David Messare</u> DOB <u>[REDACTED]</u> SUSPECT #2 _____ DOB _____ COURT <u>DECEASED</u> DATE: _____ TIME: _____ CUSTODIAL AGENCY: _____ The adult suspect in custody will appear in court for an Initial Appearance within 24 hours of arrest.	<input type="checkbox"/> SUSPECT IN CUSTODY - JUVENILE DETENTION HEARING: SUSPECT #1 _____ DOB _____ SUSPECT #2 _____ DOB _____ DETENTION CENTER: _____ The juvenile suspect in custody will appear for a Detention Hearing at the county Juvenile Court or Detention Center within 24 hours of detention, but may be released at any time prior to this hearing.
---	--	---	--

### 4 <<VICTIM OR VICTIM'S LAWFUL REPRESENTATIVE>>

A. Who was the crime or offense committed against?  
Victim: William Hunt Sex:  M  F Birth Date: \_\_\_\_\_  
B. Lawful Representative: \_\_\_\_\_ Sex:  M  F Birth Date: \_\_\_\_\_ Relationship to Victim: \_\_\_\_\_

If lawful representative, check (one) of the following which applies:

- The victim has designated me as his/her lawful representative.     The victim is incapacitated or deceased and I am an immediate family member.  
 The victim is a legal entity (corporation, partnership or business).     The victim is minor child and I am a parent, an immediate family member or legal guardian.  
 The victim is a vulnerable adult & I am the legal guardian.

C. How can you be contacted? What is your language preference?  English  Spanish  \_\_\_\_\_

Name: William Hunt  
Mailing Address: 100 Roadrunner Drive Apt: \_\_\_\_\_  
Home Address (if different): \_\_\_\_\_ Apt: \_\_\_\_\_  
City: Sedona State: AZ Zip Code: 86336  
Telephone: (Primary) 928-282-3100 (Alternate/Message) \_\_\_\_\_  
Email: \_\_\_\_\_

D.  I REQUEST my rights in this case.    OR     I WAIVE (DECLINE) my rights in this case.  
I understand that I must keep my mailing address and phone number current with the agency or court responsible for providing my rights. Failure to do so can mean that my rights are waived. I also understand in order to make any changes to the information supplied on this form, I must contact the appropriate agency or court.

(FOR REPORTING AGENCY USE ONLY)  
 REQUEST / WAIVER exception per A.R.S. § 13-4405(B) and § 8-386(B)

NOTES / COMMENTS:

Victim or Lawful Representative Signature / Date:  
 \_\_\_\_\_

**PRESS HARD - YOU ARE MAKING 5 COPIES**  
**FOR BEST COPIES - REMOVE FROM BOOK AND WRITE ON A HARD SURFACE**



**VICTIM REQUEST FOR, OR WAIVER OF, PRE-CONVICTION AND / OR PRE-ADJUDICATION RIGHTS**

This form opts you in as a victim because there is probable cause that a crime has been committed against you. Opting in does not mean you are "pressing charges." Please keep this form for future reference regarding your case.

**1** <<FORM USE>>  
 Initial Contact       By Phone/Mail      DATE: 01/20/2020  
 Victim-Initiated Change(s)       In Person

**2** <<CASE IDENTIFYING INFORMATION>>

REPORTING AGENCY: Arizona Department of Public Safety Phone #: 602-223-2000  
 Reporting Officer(s): A. Reed Complaint/Report/Citation #: I20003903  
 Location: 55 New Castle Lane Report/Citation Date/Time: 01/20/2020 1700  
 Offense/Type of Crime: Officer Involved Shooting  
 Felony     Misdemeanor     Petty Offense     Domestic Violence Issue

**3** <<ARREST / DETENTION STATUS>>

<input type="checkbox"/> <b>SUSPECT NOT IN CUSTODY</b> <input type="checkbox"/> UNKNOWN <input type="checkbox"/> KNOWN <input type="checkbox"/> ADULT <input type="checkbox"/> JUVENILE SUSPECT #1 _____ _____ DOB _____ SUSPECT #2 _____ _____ DOB _____ If an arrest/detention in this case is made, you will be notified at the earliest opportunity. If you are not notified of an arrest/detention within 30 days, you may obtain case status information by calling the law enforcement agency indicated in Box 2 above.	<input type="checkbox"/> <b>SUSPECT CITED AND RELEASED / REFERRED</b> ADULT <input type="checkbox"/> JUVENILE <input type="checkbox"/> SUSPECT #1 _____ _____ DOB _____ SUSPECT #2 _____ _____ DOB _____ COURT _____ _____ DOB _____ DATE: _____ TIME: _____ If a citation is issued, the accused may appear at any time prior to the date and time shown.	<input checked="" type="checkbox"/> <b>SUSPECT IN CUSTODY - ADULT</b> INITIAL APPEARANCE: SUSPECT #1 <u>Jonathan David Messare</u> _____ _____ DOB _____ SUSPECT #2 _____ _____ DOB _____ COURT <u>DECEASED</u> DATE: _____ TIME: _____ CUSTODIAL AGENCY: _____ The adult suspect in custody will appear in court for an Initial Appearance within 24 hours of arrest.	<input type="checkbox"/> <b>SUSPECT IN CUSTODY - JUVENILE</b> DETENTION HEARING: SUSPECT #1 _____ _____ DOB _____ SUSPECT #2 _____ _____ DOB _____ DETENTION CENTER: _____ The juvenile suspect in custody will appear for a Detention Hearing at the county Juvenile Court or Detention Center within 24 hours of detention, but may be released at any time prior to this hearing.
--	--	---	---

**4** <<VICTIM OR VICTIM'S LAWFUL REPRESENTATIVE>>

**A. Who was the crime or offense committed against?**  
 Victim: Casey Pelletier Sex:  M  F Birth Date: \_\_\_\_\_

**B. Lawful Representative:** \_\_\_\_\_ Sex:  M  F Birth Date: \_\_\_\_\_ Relationship to Victim: \_\_\_\_\_

If lawful representative, check (one) of the following which applies:  
 The victim has designated me as his/her lawful representative.     The victim is incapacitated or deceased and I am an immediate family member.  
 The victim is a legal entity (corporation, partnership or business).     The victim is minor child and I am a parent, an immediate family member or legal guardian.  
 The victim is a vulnerable adult & I am the legal guardian.

**C. How can you be contacted? What is your language preference?**  English  Spanish  \_\_\_\_\_

Name: Casey Pelletier  
 Mailing Address: 100 Roadrunner Drive Apt: \_\_\_\_\_  
 Home Address (if different): \_\_\_\_\_ Apt: \_\_\_\_\_  
 City: Sedona State: AZ Zip Code: 86336  
 Telephone: (Primary) 928-282-3100 (Alternate/Message) \_\_\_\_\_  
 Email: \_\_\_\_\_

**D.  I REQUEST my rights in this case. OR  I WAIVE (DECLINE) my rights in this case.**

I understand that I must keep my mailing address and phone number current with the agency or court responsible for providing my rights. Failure to do so can mean that my rights are waived. I also understand in order to make any changes to the information supplied on this form, I must contact the appropriate agency or court.

Victim or Lawful Representative Signature / Date: [Signature]

(FOR REPORTING AGENCY USE ONLY)  
 **REQUEST / WAIVER exception per A.R.S. § 13-4405(B) and § 8-386(B)**

NOTES / COMMENTS:



Arizona Department of Public Safety  
 Arizona Counter Terrorism Information Center  
 Computer Forensics Unit  
 cfu@azdps.gov  
 (602) 223-2212 for 24-hour assistance



## EXAMINATION REQUEST FORM

DPS EVIDENCE DR NUMBER: \_\_\_\_\_ REQUESTING AGENCY DR NUMBER: \_\_\_\_\_  
 DPS Evidence DR Number: \_\_\_\_\_ I20003903

DATE: 2/13/2020 REQUESTING AGENCY: AZDPS PRIORITY LEVEL:  High  Medium  Low

INVESTIGATION TYPE: Officer Involved Shooting (Aggravated Assault/Aggravated Assault on a Peace Officer)

CASE AGENT: A. Reed BADGE NUMBER: 7325 E-MAIL ADDRESS: areed@azdps.gov

WORK PHONE NUMBER: 602-826-1321 CELL PHONE NUMBER: Cell Phone Number

AUTHORIZATION TO SEARCH (Check One)  
 Search Warrant – Warrant Number: 2020-000836  Probation Request  
 Administrative Investigation  Internal Investigation  
 Written Consent  Abandoned Property

### SUSPECT INFORMATION

SUSPECT NAME: Jonathan David Messare SUSPECT DATE OF BIRTH: [REDACTED]  
 Second Suspect Name: \_\_\_\_\_ DOB: \_\_\_\_\_  
 Third Suspect Name: \_\_\_\_\_ DOB: \_\_\_\_\_

### VICTIM INFORMATION

VICTIM NAME: Victim's Name VICTIM DATE OF BIRTH: DOB

### EVIDENCE ITEMS TO BE EXAMINED

ITEM #	DESCRIPTION	ITEM #	DESCRIPTION
9334	Black CAT cellular phone	#	Description
#	Description	#	Description
#	Description	#	Description
#	Description	#	Description
#	Description	#	Description
#	Description	#	Description

### DESCRIBE REQUEST

Be specific on Analysis or Examination needed to include dates, times, or other information if applicable.  
 A full physical/logical cell phone extraction.

**INVESTIGATION SUMMARY (or Provide Affidavit)**

Please see affidavit

**LIST CASE SPECIFIC KEY WORDS (non-generic words)**

Click or tap here to enter text.



**ARIZONA DEPARTMENT OF PUBLIC SAFETY**  
**VI. PHOTOGRAPHS**

**DR NUMBER:**

**I20003903**

1. Photographs taken by AZDPS Photographic Specialist Deane Tonne, #7893

Detective Name	ID No.	Location	Date	Supervisor
Andrew Reed	7325	31030100	01/22/2020	Sergeant Matthew Monaco, #6645